

Industrial Vacuum Tankmount Systems

Please read and save these instructions. Read carefully before attempting to assemble, install, operate or maintain the product described. Protect yourself and others by observing all safety information. Failure to comply with instructions could result in personal injury and/or property damage! Retain instructions for future reference.

Description

General

Powerex vacuum tank mount simplex/duplex units are designed to provide vacuum for process, molding, packaging, printing and other similar facilities. Vacuum tank mount systems can be used for a variety of applications where the fluid being moved is primarily air or inert gas. Some water vapor may be contained in the fluid, and it will be transferred to the outlet stream. No liquid must reach the vacuum system. The system is not designed to handle flammable or aggressively corrosive fluids. Liquid water or other liquids must be separated and collected upstream of the Powerex system and disposed of as needed. The exhaust stream of the vacuum pump will contain the process gas and may contain some trace oil from the pump operation. Exhaust flow can be vented remotely using piping, or the room can be ventilated if suitable.

Safety Guidelines

This manual contains information that is very important to know and understand. This information is provided for SAFETY and to PREVENT EQUIPMENT PROBLEMS. To help recognize this information, observe the following symbols.

⚠ DANGER *Danger indicates an imminently hazardous situation which, if not avoided, WILL result in death or serious injury.*

⚠ WARNING *Warning indicates a potentially hazardous situation which, if not avoided, COULD result in death or serious injury.*

⚠ CAUTION *Caution indicates a potentially hazardous situation which, if not avoided, MAY result in minor or moderate injury.*

NOTICE *Notice indicates important information, that if not followed, may cause damage to equipment.*

NOTE: Note indicates information that requires special attention.

Components

Vacuum Tankmount Systems

The IVS and IVD (Vacuum Tankmount Simplex and Duplex) systems consist of one or two rotary vane vacuum pumps that can be operated independently or in tandem. The system will operate the pump or pumps to maintain the vacuum level determined by the control panel settings. The duplex systems control panel automatically sequences the pumps to maintain equal run time on each pump. The direct drive

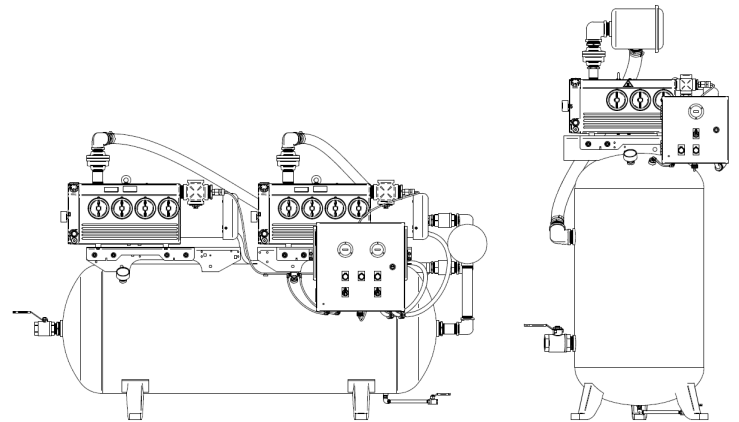

SPECIFICATIONS		
Product	IVS/IVD Series	
Operating Voltages	208V, 230V, 460V	
Control Panel	UL508A and NFPA compliant	
Motor	TEFC Electric Motor	
Tank	ASME Rated for 200 psi MAWP/Full Vacuum	
Pump	Capable of operating at: See table with Engineering Specifications	
Drive	Direct	
Tank Sizes	See Page 2	
Performance	See Page 2	
Inlet Vacuum Connections	IVS 1 HP – 1 inch 1.5 HP to 5 HP – 1 ½ inch 7.5 HP to 10 HP – 2 inch	IVD -- 1 HP to 5 HP – 1 ½ inch 7.5 HP to 10 HP – 2 inch

vacuum pump is equipped with a continuous duty TEFC induction motor. Maintenance on the rotary vane pump is simplified through convenient access to both ends of the pumps.

The pump or pumps draw air through a 10 micron polyester filter and external check valve. An additional built-in anti-reverse flow valve is provided for added protection against leakage. A stainless steel protective screen is built into the inlet flange as standard equipment on the pumps. The inlet screen protects the pump from large particles entering the rotor/vane area.

The pumps have a built in gas ballast valve to help prevent moisture accumulation.

Engineering Specifications

Industrial Tankmount Simplex and Duplex

	Model	System HP	Pump HP	SCFM @ 19" Hg	Tank (gal) and configuration	Heat generation at full load/100% duty BTU/hr
Simplex	IVS0151xx	1.5	1.5	6	30 V	3200
	IVS0152xx	1.5	1.5	6	60 V	3200
	IVS0202xx	2	2	11	60 V	4300
	IVS0303xx	3	3	16	80 V	6500
	IVS0403xx	5	5	26	80 H	8700
	IVS0503xx	5	5	37	80 H	10800
	IVS0754xx	7.5	7.5	47	120 H	16200
	IVS1004xx	10	10	68	120 H	21600
	IVS1005xx	10	10	68	200 H	21600
Duplex	IVD0153xx	3	1.5 (2)	12	80 H	6500
	IVD0203xx	4	2 (2)	22	80 H	8700
	IVD0303xx	6	3 (2)	32	80 H	13000
	IVD0304xx	6	3 (2)	32	120 H	13000
	IVD0404xx	10	5 (2)	48	120 H	17500
	IVD0504xx	10	5 (2)	74	120 H	21600
	IVD0505xx	10	5 (2)	74	200 H	21600
	IVD0755xx	15	7.5 (2)	94	200 H	32400
	IVD1005xx	20	10 (2)	136	200 H	43300
	IVD1006xx	20	10 (2)	136	240 H	43300

* End vacuum is 29.9" Hg (29.6" for 1.5 HP pump), ACFM is measured at actual inlet conditions, SCFM is measured at standard conditions (68° F, 29.92" Hg or 14.7 psia)

* Control panel will include a magnetic starter with overload protection, an hour meter, an on/off switch or a selector switch, and a minimum run timer (5HP and above) for each pump. Duplex starter will include an alternator.

NOTE: For system electrical information, see the wiring diagram shipped with the unit.

Receiver Tank

The receiver tank is an ASME registered pressure vessel rated for 200psig maximum allowable working pressure and suitable for full vacuum. It is installed in the system in a flow through arrangement. The receiver is not intended to be a liquid collector, and failure to provide effective liquid removal upstream of the IVS or IVD system may damage the pumps and void warranty. A vacuum gauge is installed and a manual tank drain valve is included.

CAUTION *Factory installed receiver is used for vacuum capacity only and is NOT a collection receiver.*

DANGER *Never drill holes in, or perform any welding on tanks or use them beyond the rated pressure settings.*

Control Panel

The NEMA 1, UL listed control panel is provided in simplex or duplex configurations. Both utilize a 120V AC control transformer with fused primary and secondary circuit. The pumps are signaled to come on cycle by an adjustable vacuum switch or switches. The switches have

a fixed "dead band" of approximately 3 in Hg.

All Powerex vacuum systems employ minimum run timers via a PLC or time delay relay for each pump. Minimum run timers will assure that no more than six starts per hour can occur on each pump. If the vacuum level is sufficient and the minimum run timer is satisfied, the pump will automatically turn off. The minimum run timer prevents rapid stopping and starting that can damage the motor, coupling or other pump components and helps keep the pump warm for dissipation of moisture in the process stream. A duplex unit employs timed alternation via the PLC or timer to maintain even run hours on each pump.

The control panel is provided with a HOA (hand-off-auto) switch and hour meter for each pump. A high temperature sensor is included to detect harmful conditions and shut off the pump. The high temperature circuit must be manually reset if triggered. Controls will automatically restart if power is lost and restored.

System Check Valves

In addition to the anti-reverse flow valves incorporated into the body of the pumps, the Powerex IVS and IVD systems have system check valves to preserve vacuum in the receiver and process lines when the pumps are turned off.

Intake Filters

The intake filters protect against particulates that could damage the pumps. Elements are replaceable and are design to resist collapse.

NOTICE *the filters do not prevent damaging liquid induction into the pumps. Relief ports are provided so that covers can be removed without waiting for vacuum to decay by leakage.*

Optional Lined Receiver Tank

A corrosion resistant tank lining is offered for applications where this characteristic is desired.

Inlet Ball Valve

The system inlet has an isolation ball valve installed for convenient service.

Drip Leg

The pump exhaust fittings are supplied with a pipe tee where the down facing leg is fitted with a drain valves to facilitate draining any condensed liquid that accumulates in the exhaust piping. The exhaust piping should be installed so that liquids that condense are not drained back to the pump.

Vibration Isolation Mounting Pads

The pumps have inherently low vibration due to the rotary design. Vibration isolation mounting feet are incorporated into the pump design so that even these minimal vibrations are not transmitted into the frames and tanks. Cork-rubber composite mounting pads may be installed under the tank feet or base platform if desired, but are not required for system operation.

Optional Auto-Purge Controls

For processes where it is undesirable to leave process gas in the pumps on shutdown, Auto-purge controls in an NEMA 4 enclosure are available. The auto-purge cycle isolates the pump from the process flow and flushes it with clean air before shutting it down.

Optional Nema 4 control enclosure with standard controls is also available.

Optional Flex Hoses

Systems can be ordered with flexible stainless steel (convoluted type) hoses with NPT-male ends for ease of connection to facility piping.

Unpacking

Immediately upon receipt of the vacuum system, inspect for any damage which may have occurred during shipment. Repair or replace damaged items before use. The specification decal should be checked to verify the correct model and voltage.

WARNING *Do not operate unit if damaged during shipping, handling or use. Damage may result in unsafe conditions and cause injury or property damage.*

CAUTION *Do not lift or move unit without appropriately rated equipment. Be sure the unit is securely attached to lifting device used. Do not lift unit by holding onto tubes or coolers. Do not use pumps to lift other attached equipment.*

The Powerex IVS and IVD vacuum systems are shipped in protective wooden crates and bolted to wooden skids. The skids provide fork lift access for lifting and moving the units. The system is intended to be removed from the skid for installation onto the solid floor of the building.

If any damage is detected when the system is unpacked, contact the shipping company to file appropriate freight damage claims. Correct any damage before operating the unit.

Installation Site

1. The vacuum system must be located in a clean, well lit and well-ventilated area.
2. The area should be free of excessive dust, toxic or flammable gases and moisture.
3. Never install the vacuum system where the surrounding temperature is higher than 104 ° F (40 ° C) or where humidity is high.
4. Clearance must allow for safe, effective inspection and maintenance.

Minimum Clearances	
Above	24 in
Space in front of electric panel	36 in (check local codes, additional space may be required.)
All other sides	24 in

5. If necessary, use metal shims or leveling pads to level the compressor tank or basemount unit. Never use wood to shim the unit.
6. The unit has mounting holes to allow bolting to the floor. Secure it as necessary. Rubber composite isolation pads should be used to minimize transmission of noise and vibration to the building. Additional measures for isolation may be required. Drill a hole through the isolation pad and center it under the mounting point.
7. Room air circulation must be provided to avoid local stagnant areas that can cause pump overheating.

Wiring

⚠ DANGER Lock out and tag out the electrical supply before servicing the equipment.

⚠ DANGER Electrical shock hazard. Make sure the system is grounded in accordance with NEC and local requirements.

All electrical hook-ups must be performed by a qualified electrician. Installations must be in accordance with local and national electrical codes. Make sure power supply conductors are sized adequately for full system demand.

Piping

The system may have temporary shipping supports in place. These should be removed when the system piping is connected to the building piping. Appropriate supports should be added to the system when building tie in is completed.

The system has a single point inlet. An optional flexible connector is available. An optional flexible connector for tying in to the system exhaust is also available.

1. Make sure the piping is lined up without being strained or twisted when assembling the piping for the unit.
2. Appropriate expansion loops or bends should be installed at the unit to avoid stresses caused by changes in hot and cold conditions.
3. Piping supports should be anchored separately from the unit to reduce noise and vibration.
4. Never use any piping smaller than the unit inlet and outlet connection.
5. Use flexible hose to connect the inlet and outlet of the unit to the piping so that the vibration of the unit does not transfer to the piping.
6. A drip leg and drain valve must be installed for any exhaust piping that collects moisture after the pump outlet connections. The Powerex drip leg is not suitable for draining the complete exhaust system.
7. The exhaust piping should be kept short and have the least restriction possible. The flex connector supplied by Powerex may be repositioned (changed from vertical to horizontal and the elbow turned or removed) if desired to achieve a more effective installation to match the field installed exhaust piping. Repositioning is desirable if the final system plumbing design can be shorter by doing so.
8. Never use any piping smaller than the pump connection. To determine the minimum required pipe size for a vacuum system exhaust, calculate the equivalent straight length of the run. Never use a pipe size smaller than the flex connector supplied by Powerex or smaller than the size shown in the 100 foot column on the chart for the CFM of the pump. The equivalent straight length is the length of all the pipe needed from the flex connector to the final outlet plus a factor for each

elbow, cross or tee. Pipe must be smooth ID. If rough pipe is used, increase by one size.

NOTICE The IVS and IVD systems do not have a service disconnect or branch circuit protection. These must be provided in accordance with NEC and any local codes at the time of installation.

9. If a grating or grille is used at the end of the exhaust pipe, make sure its open area is at least equal to the area of the exhaust pipe.

PIPE SIZE REQUIREMENTS			
System CFM	Minimum Pipe Size for 100 feet	Minimum Pipe Size for 300 feet	Minimum Pipe Size for 600 feet
5	1.0	1.25	1.5
7	1.0	1.25	1.5
11	1.25	1.5	1.5
21	1.25	1.5	1.5
26	1.25	1.5	2.0
32	1.25	1.5	2.0
38	1.5	2.0	2.5
52	1.5	2.0	2.5
58	1.5	2.5	2.5
63	2.0	2.5	2.5
65	2.0	2.5	3.0
87	2.0	2.5	3.0
104	2.0	3.0	3.5
111	2.5	3.0	3.5
154	2.5	3.0	3.5
156	2.5	3.5	4.0
168	2.5	3.5	4.0
195	3.0	3.5	4.0
258	3.0	3.5	4.0
260	3.5	4	5.0
387	3.5	4	5.0
516	4	5	6.0

If the system extends beyond 600 equivalent straight feet, use one size larger pipe.

Approximate system CFM equals the number of pumps running times CFM in table below. (Data below is for reference only, if actual pump CFM is higher than shown, use the higher value.)

HP	Vane Pump CFM @ 19"	Claw Pump CFM @ 19"
1.0	2.0	
1.5	7	
2.0	11	16
3.0	17	21
4.0		29
5.0	26	
5.0	38	
5.4		38
6.4		52
7.5	52	65
8.7		77
10.0	65	84
10.0	77	
15.0	111	129
20.0	137	
25.0	168	

Pipe Size	Equivalent length for 90° elbow, cross, or tee	Equivalent length for 45° elbow
	3.0 feet	1.5 feet
1.5	3.75 feet	1.8 feet
2.0	5.0 feet	2.5 feet
2.5	6.25 feet	3.1 feet
3.0	7.5 feet	3.8 feet
3.5	8.78 feet	4.4 feet
4.0	10.0 feet	5.0 feet
5.0	12.5 feet	6.25 feet

NOTICE If the IVS or IVD system is going to be operated with cut in vacuum levels less than 19 inHg (closer to atmospheric condition) the scfm will be higher and the exhaust piping size should be increased. Use 1 psi as the maximum pressure drop in the exhaust piping.

Operation

Before Start Up

1. Make sure all safety warnings, labels and instructions have been read and understood before continuing.
2. Remove any shipping materials, brackets, etc.
3. Confirm electric power source and ground have been firmly connected.
4. Be sure all vacuum connections are tight.
5. Ensure all fuses, circuit breakers, etc., are properly sized.
6. Make sure inlet filter is properly installed.
7. Close drain valve.

WARNING Risk of injury. Make sure no one is in contact with any moving parts during the rotation check.

Start Up & Operation

1. Follow all procedures under "Before Start-Up" before attempting operation of the vacuum pump.
2. Switch the electric source breaker on.
3. Visually check rotation of vacuum pump. If rotation is incorrect, have a qualified electrician correct motor wiring.

NOTICE The intake filters supplied by Powerex will not stop ingestion of liquid water by the pumps. Liquid water going into the pumps will damage the pumps and void the warranty.

4. Open tank intake valve completely.
5. Check for excessive vibration, unusual noises or leaks during operation.
6. Close intake valve completely.
7. Check the vacuum (inch / Hg.). Ensure designated vacuum setting is reached by checking vacuum gauge.

Maintenance Schedule

1. Inspect the unit frequently, especially at start –up and if the operating conditions change to determine if the system is operating as expected. Pay close attention to the condition of the lubricating oil and to any liquid accumulations.
2. The pump and filter maintenance schedules are established based on normal operating temperatures and contaminant loads. If operating in environments exceeding 85F the oil may require more frequent changing and filters may require more frequent attention if loads are higher.
3. Operation with gases that have oxidizing properties in the process stream may require more frequent oil and oil filter changes.
4. Some operating conditions may require more frequent changing of separator filters. If exhaust stream contains significant oil, or if the pressure in the crankcase is higher than normal, follow instructions in the pump manual.
5. If oil in the pump becomes milky or foamy, follow instructions in the pump manual.

Item	Action Needed	Operating Hours										Remarks
		Daily	100	500	2,000	2,500	5,000	10,000	15,000	20,000		
Inlet Air Filter	Inspect Replace			●		▲						Inspect every 500 hours; Replace every 2500 hours or less
Blower Fan	Clean						●	●	●	●		
Fan Shield	Clean						●	●	●	●		
Pump Fans	Clean						●	●	●	●		
Vacuum Switch	Inspect						●	●	●	●		
Oil Level	Inspect	●										Check oil level and condition daily; See pump manual for details
Oil												See pump manual for details and instructions.
Oil Filter												See pump manual for details and instructions.
Drip Leg Drain			●									Open every 100 hours of use and allow to drain; inspect proper working order
Exhaust Filters	See the pump manual for details. Replace exhaust filters on Busch pumps every 9 to 12 months. On Becker pumps, replace the separators every 2000 hours and replace the coarse separators every 5,000 hours.											
LEGEND												
● Inspect												
▲ Replace												

Vertical Tankmount Simplex

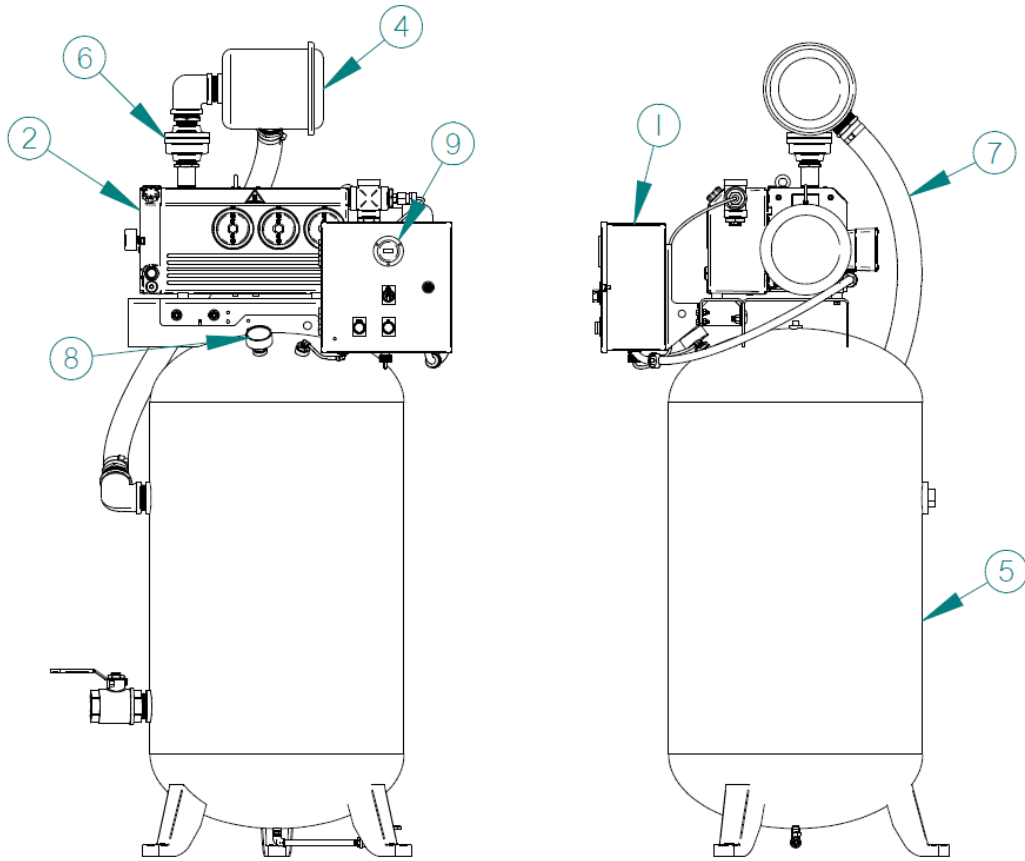

Ref. #	Description	IVS015	IVS020	IVS030	Qty
1	Motor Starter 208V	PVI19T12AJ	PVI19T22AJ	PVI19T32AJ	1
	Motor Starter 230V	PVI19T13AJ	PVI19T23AJ	PVI19T33AJ	1
	Motor Starter 460V	PVI19T14AJ	PVI19T24AJ	PVI19T34AJ	1
2	Vacuum Pump/Motor Assembly 208V	VPR01501AV	VPR02001AV	VPR03000AV	1
	Vacuum Pump/Motor Assembly 230/460V	VPR01500AV	VPR02000AV	VPR03000AV	1
	Vacuum Switch (not shown)	VP001303AV	VP001303AV	VP001303AV	1
4*	Inlet Air Filter Element	VP000508AV	VP000509AV	VP000510AV	1
5	Receiver Tank 30 gal	AR024200ST	—	—	1
	Receiver Tank 60 gal	AR231601ST	AR231601ST	—	1
	Receiver Tank 80 gal	—	—	AR063000ST	1
6	Check Valve	VP002301AV	VP002303AV	VP002303AV	1
7	Vacuum Hose	HA001300AV (3ft)	HA001301AV (3ft)	HA001302AV (3ft)	1
8	Vacuum Gauge	ST073334AV	ST073334AV	ST073334AV	1
9	Hour Meter	PE001004AV	PE001004AV	PE001004AV	1
	Oil	VP002401AV	VP002401AV	VP002401AV	See Pump Manual
	Separator Filter	VP002402AV	VP002403AV	VP002403AV	See Pump Manual

Horizontal Tankmount Simplex

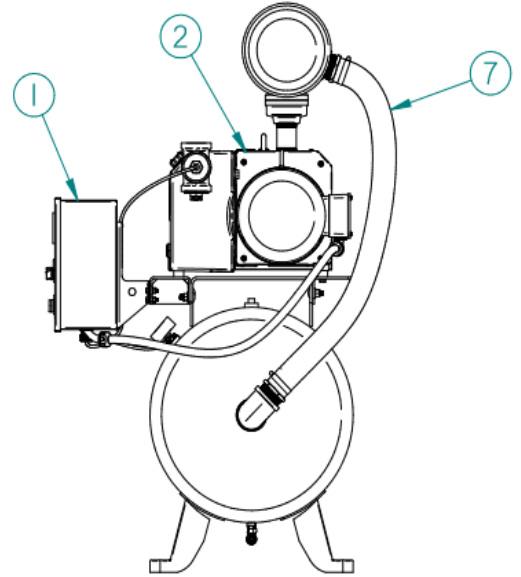
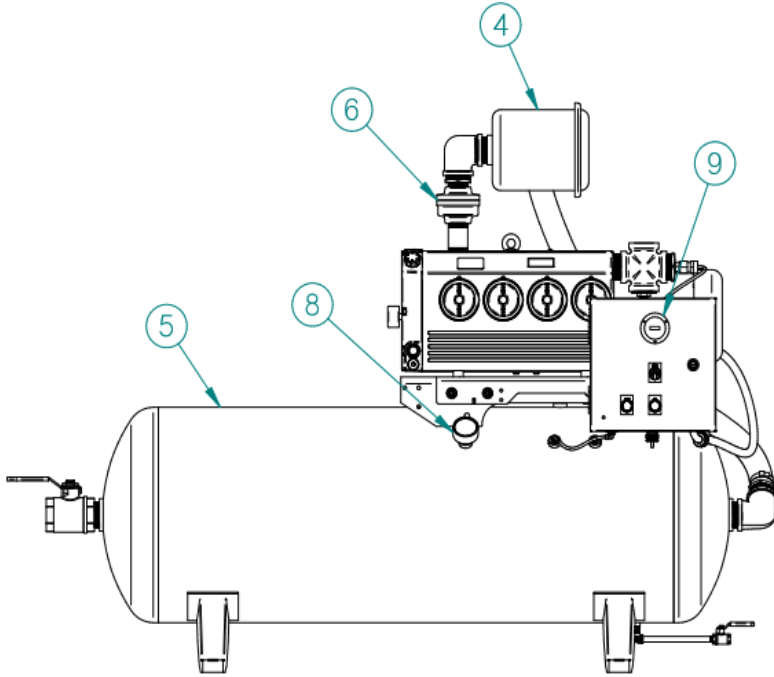

Ref. #	Description	IVS040	IVS050	IVS075	IVS100	Qty
1	Motor Starter 208V	PVI19T42AJ	PVI19T52AJ	PVI19T72AJ	PVI19TA2AJ	1
	Motor Starter 230V	PVI19T43AJ	PVI19T53AJ	PVI19T73AJ	PVI19TA3AJ	1
	Motor Starter 460V	PVI19T44AJ	PVI19T54AJ	PVI19T74AJ	PVI19TA4AJ	1
2	Vacuum Pump/Motor Assembly 208V	VPR05001AV	VPR05003AV	VPR03000AV	VPR07501AV	1
	Vacuum Pump/Motor Assembly 230/460V	VPR05000AV	VPR05002AV	VPR03000AV	VPR07500AV	1
3	Vacuum Switch (not shown)	VP001303AV	VP001303AV	VP001303AV	VP001303AV	1
4*	Inlet Air Filter Element	VP000510AV	VP000510AV	VP000510AV	VP000510AV	1
5	Receiver Tank 80 gal	AR023400ST	AR023400ST	–	–	1
	Receiver Tank 120 gal	–	–	AR022400ST	AR022400ST	1
	Receiver Tank 200 gal	–	–	–	JQ000200AJ	1
6	Check Valve	VP002304AV	VP002304AV	VP002305AV	VP002305AV	2
7	Vacuum Hose	HA001302AV (3ft)	HA001302AV (3ft)	HA001302AV (3ft)	HA001302AV (3ft)	1
8	Vacuum Gauge	ST073334AV	ST073334AV	ST073334AV	ST073334AV	1
9	Hour Meter	PE001004AV	PE001004AV	PE001004AV	PE001004AV	1
	Oil	VP002401AV	VP002401AV	VP002401AV	VP002401AV	See Pump Manual
	Separator Filter	VP002404AV	VP002404AV	VP002405AV	VP002405AV	See Pump Manual

Horizontal Tankmount Duplex

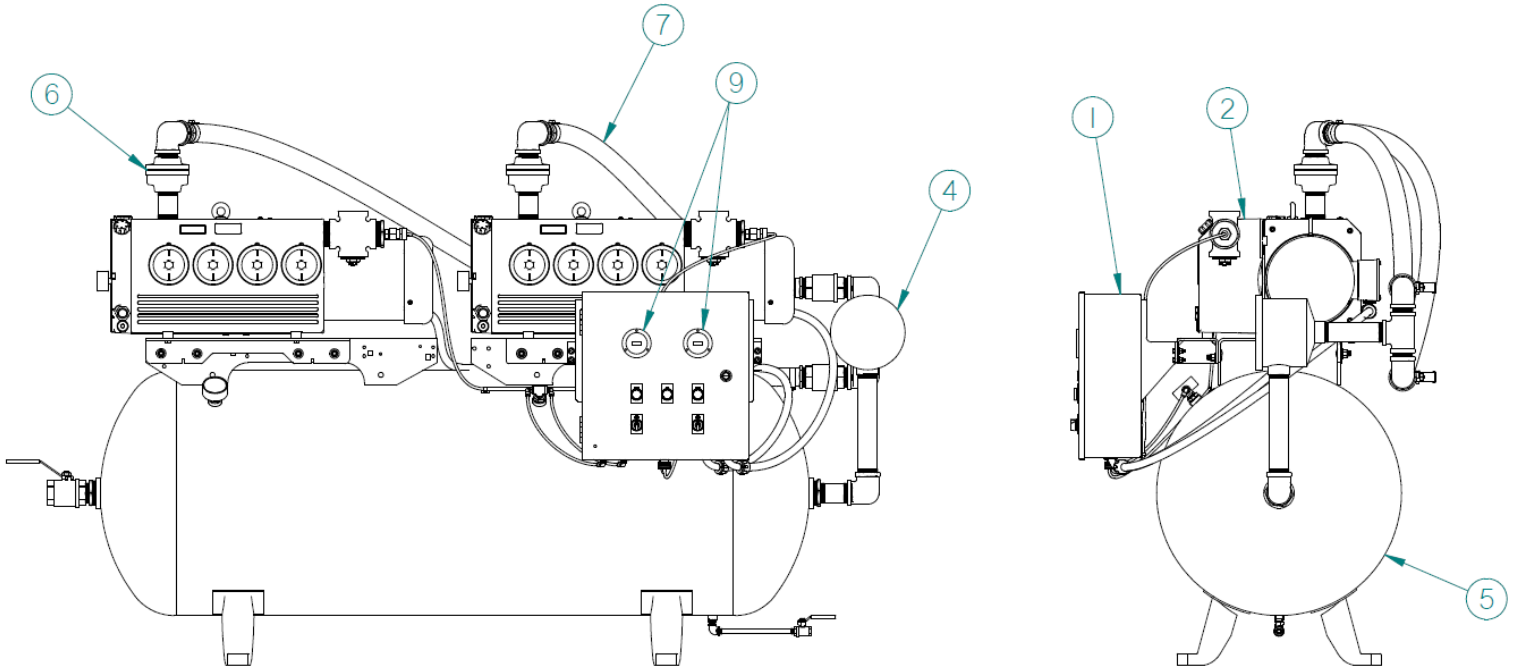

Ref. #	Description	IVD015	IVD020	IVD030	Qty
1	Motor Starter 208V	PVI29T12AJ	PVI29T22AJ	PVI29T32AJ	1
	Motor Starter 230V	PVI29T13AJ	PVI29T23AJ	PVI29T33AJ	1
	Motor Starter 460V	PVI29T14AJ	PVI29T24AJ	PVI29T34AJ	1
2	Vacuum Pump/Motor Assembly 208V	VPR01501AV	VPR02001AV	VPR03000AV	2
	Vacuum Pump/Motor Assembly 230/460V	VPR01500AV	VPR02000AV	VPR03000AV	2
3	Vacuum Switch (not shown)	VP001303AV	VP001303AV	VP001303AV	2
4*	Inlet Air Filter Element	VP000509AV	VP000509AV	VP000509AV	1
5	Receiver Tank 80 gal	AR022900ST	AR022900ST	AR022900ST	1
	Receiver Tank 120 gal	–	–	AR022800ST	1
	Receiver Tank 200 gal	–	–	–	1
	Receiver Tank 240 gal	–	–	–	1
6	Check Valve	VP002301AV	VP002303AV	VP002303AV	2
7	Vacuum Hose 1	HA001300AV (3ft)	HA001301AV (3ft)	HA001301AV (3ft)	1
	Vacuum Hose 2	HA001300AV (6ft)	HA001301AV (6ft)	HA001301AV (6ft)	1
8	Vacuum Gauge	ST073334AV	ST073334AV	ST073334AV	2
9	Hour Meter	PE001004AV	PE001004AV	PE001004AV	2
	Oil	VP002401AV	VP002401AV	VP002401AV	See Pump Manual
	Oil Filter	VP002401AV	VP002401AV	VP002401AV	See Pump Manual
	Separator Filter	VP002402AV	VP002403AV	VP002403AV	See Pump Manual

Horizontal Tankmount Duplex (continued)

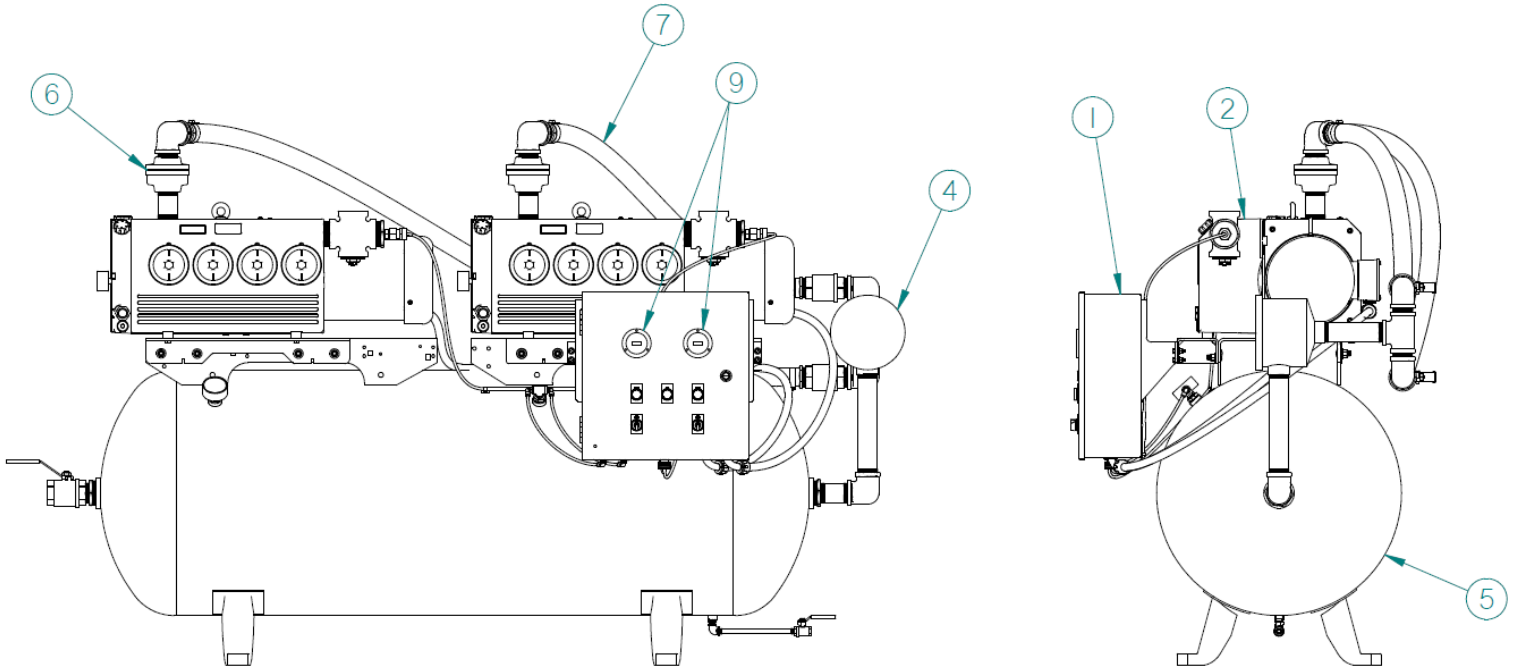

Ref. #	Description	IVD040	IVD050	IVD075	IVD100	Qty
1	Motor Starter 208V	PVI29T42AJ	PVI29T52AJ	PVI29T72AJ	PVI29TA2AJ	1
	Motor Starter 230V	PVI29T43AJ	PVI29T53AJ	PVI29T73AJ	PVI29TA3AJ	1
	Motor Starter 460V	PVI29T44AJ	PVI29T54AJ	PVI29T74AJ	PVI29TA4AJ	1
2	Vacuum Pump/Motor Assembly 208V	VPR05001AV	VPR05003AV	VPR03000AV	VPR07501AV	2
	Vacuum Pump/Motor Assembly 230/460V	VPR05000AV	VPR05002AV	VPR03000AV	VPR07500AV	2
3	Vacuum Switch (not shown)	VP001303AV	VP001303AV	VP001303AV	VP001303AV	2
4*	Inlet Air Filter Element	VP000509AV	VP000509AV	VP000510AV	VP000510AV	1
5	Receiver Tank 80 gal	–	–	–	–	1
	Receiver Tank 120 gal	AR022800ST	AR022800ST	–	–	1
	Receiver Tank 200 gal	–	JQ000200AJ	JQ000200AJ	JQ000200AJ	1
	Receiver Tank 240 gal	–	–	–	JQ000100AJ	1
6	Check Valve	VP002304AV	VP002304AV	VP002305AV	VP002305AV	2
7	Vacuum Hose 1	HA001301AV (3ft)	HA001301AV (3ft)	HA001302AV (3ft)	HA001302AV (3ft)	1
	Vacuum Hose 2	HA001301AV (6ft)	HA001301AV (6ft)	HA001302AV (6ft)	HA001302AV (6ft)	1
8	Vacuum Gauge	ST073334AV	ST073334AV	ST073334AV	ST073334AV	2
9	Hour Meter	PE001004AV	PE001004AV	PE001004AV	PE001004AV	2
	Oil	VP002401AV	VP002401AV	VP002401AV	VP002401AV	See Pump Manual
	Oil Filter	VP002401AV	VP002401AV	VP002401AV	VP002401AV	See Pump Manual
	Separator Filter	VP002404AV	VP002404AV	VP002405AV	VP002405AV	See Pump Manual

Vacuum System Flow Schematic for Basic Systems

Simplex

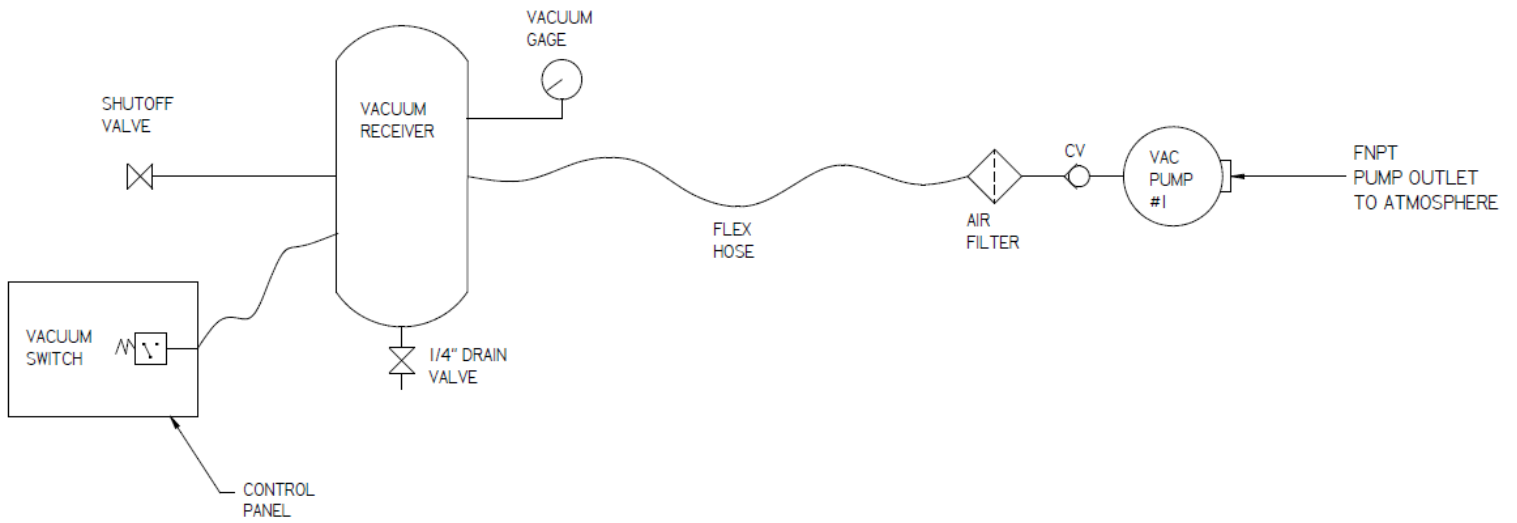

Duplex

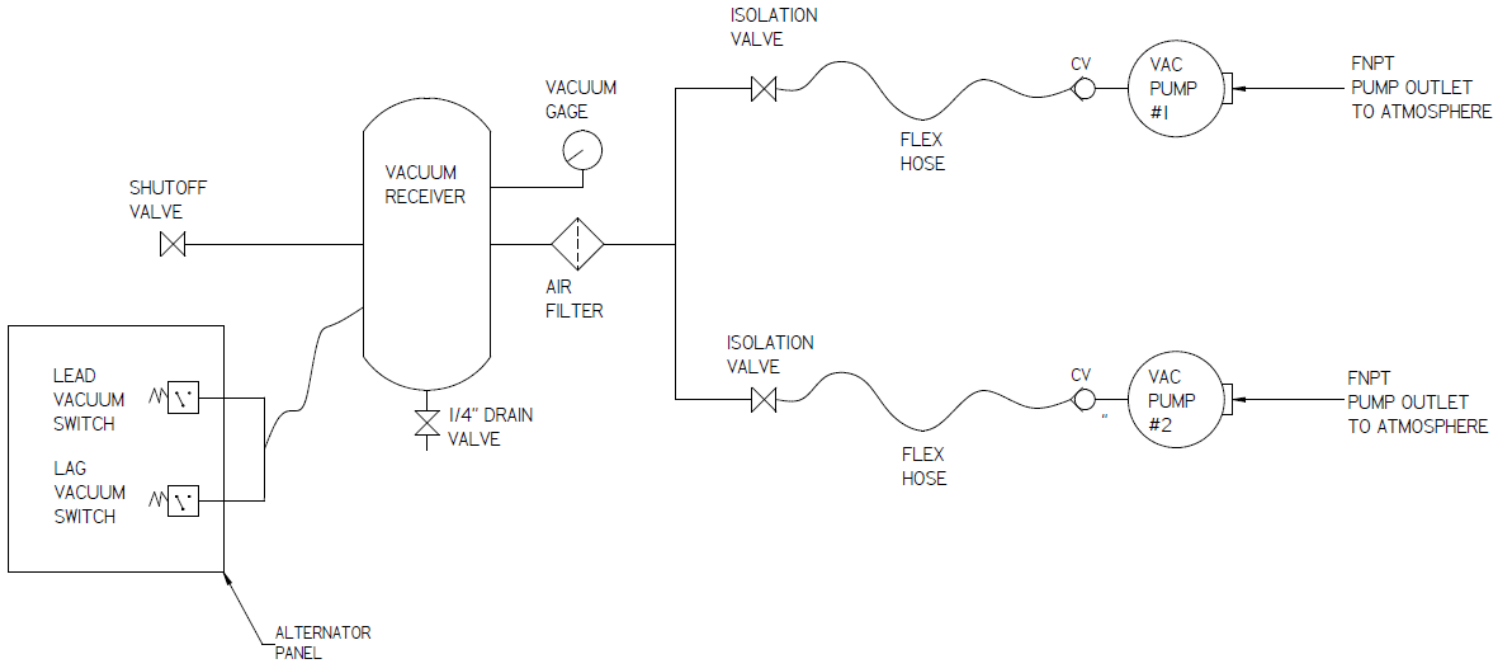

Auto Purge System Flow Schematic

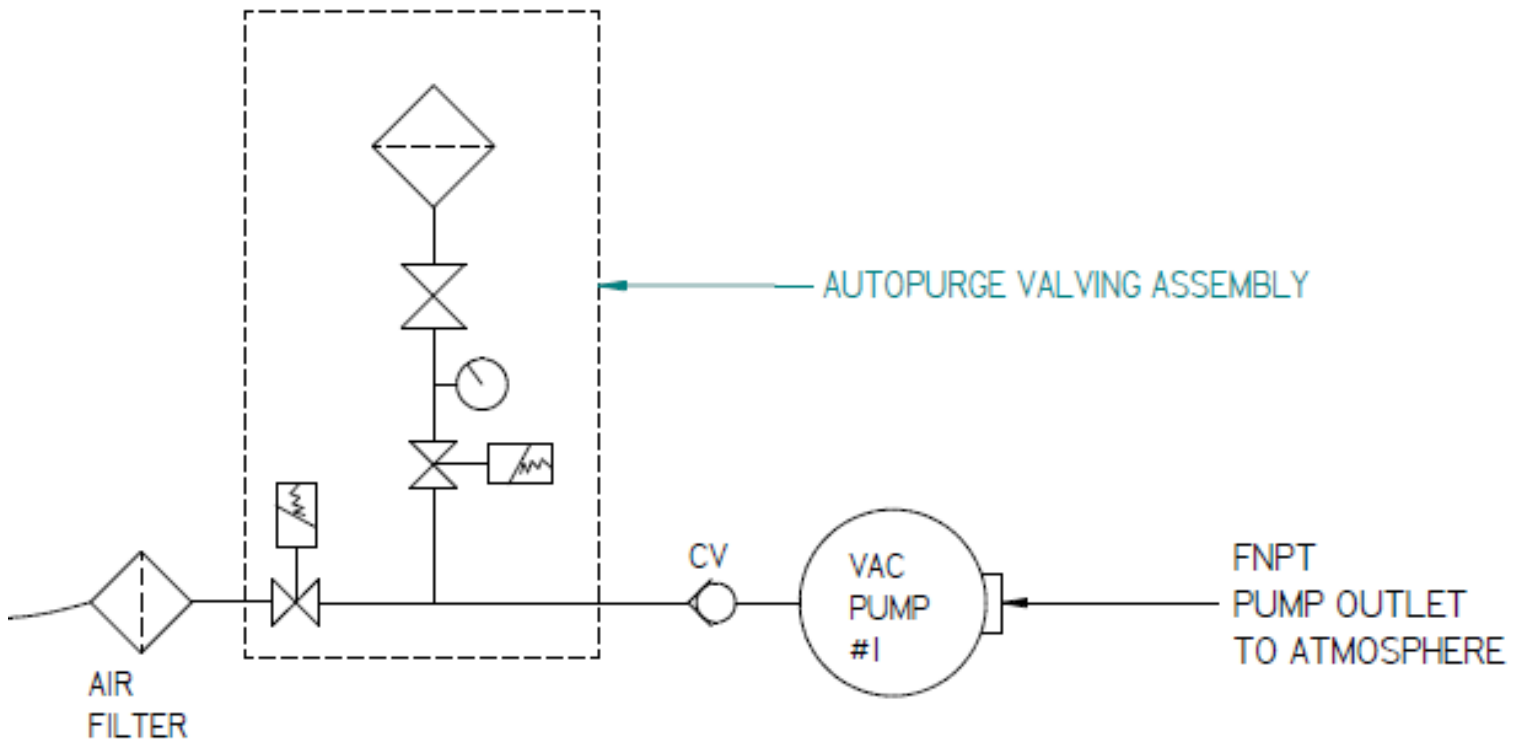

Operation of the Auto Purge System

The Powerex control will close the isolation solenoid and open the purge solenoid when Auto-purge is active. This will allow fresh clean air to be drawing through the small filter assembly. The manual control valve between the air filter and purge control solenoid should be opened so that the vacuum level on the gauge is between 19 and 20 inches Hg.

Notes

Notes

Notes

Powerex Limited Warranty – Applicable to Non-OEM Customers in the U.S. & Canada Only

Warranty and Remedies.

(a) General. Powerex warrants each Compressor System, Vacuum System, Vacuum Pump, Compressor Air-End, or Powerex branded Accessory (collectively “Products”, individually each a “Product”) to be free from defects in material and workmanship (“Defects”) at the date of shipment. This warranty shall apply only to Products that are purchased and used in the United States of America and in Canada. EXCEPT AS SET FORTH BELOW, NO OTHER WARRANTY, WHETHER EXPRESS OR IMPLIED, INCLUDING ANY WARRANTY OF MERCHANTABILITY OR FITNESS FOR A PARTICULAR PURPOSE, SHALL EXIST IN CONNECTION WITH THE SALE OR USE OF SUCH PRODUCTS. TO THE EXTENT PERMITTED BY LAW, ANY AND ALL IMPLIED WARRANTIES ARE EXCLUDED. All warranty claims must be made in writing and delivered to Powerex in accordance with the procedures set forth on its website (www.powerexinc.com), or such claim shall be barred. Upon timely receipt of a warranty claim, Powerex shall inspect the Product claimed to have a Defect, and Powerex shall repair, or, at its option, replace, free of charge, any Product which it determines to have had a Defect; provided, however, that if circumstances are such as to preclude the remedying of Defect by repair or replacement, Powerex shall, upon return of the Product, refund to buyer any part of the purchase price of such Products paid to Powerex. Freight for returning Products to Powerex for inspection shall be paid by buyer. The warranties and remedies herein are the sole and exclusive remedy for any breach of warranty or for any other claim based on any Defect, or non-performance of the Products, whether based upon contract, warranty or negligence.

(b) (i) Standard Period of Warranty – Parts and Labor. The purchase of any system includes our standard warranty. Powerex warrants and represents all Products shall be free from Defects for the first eighteen (18) months from the date of shipment by Powerex, or twelve (12) months from the documented date of startup, or five thousand (5,000) hours of use, whichever occurs first. During such warranty period, Powerex shall be fully liable for all Defects in the Products (the “Product Defects”), i.e., all costs of repair or replacement, which may include “in and out” charges, so long as the Products are located in the United States or Canada, and the Products are reasonably located and accessible by service personnel for removal. “In and out” charges include the costs of removing a Product from buyer’s equipment for repair or replacement.

(ii) Premium Period of Warranty – Parts and Labor. In order to be eligible for premium warranty coverage, a premium warranty for each system must be purchased when order is placed. Powerex warrants and represents all Products shall be free from Defects for the first thirty (30) months from the date of shipment by Powerex, or twenty-four (24) months from the documented date of startup, or seven thousand five hundred (7,500) hours of use, whichever occurs first. During such warranty period, Powerex shall be fully liable for all Defects in the Products (the “Product Defects”), i.e., all costs of repair or replacement, which may include “in and out” charges, so long as the Products are located in the United States or Canada, and the Products are reasonably located and accessible by service personnel for removal. “In and out” charges include the costs of removing a Product from buyer’s equipment for repair or replacement.

(c) Additional Period of Warranty – Parts Only (No Labor). In addition to the above, Powerex warrants each Powerex branded Compressor Air-End and Vacuum Pump shall be free of Defects for a period of forty-two (42) months from the date of shipment by Powerex, or thirty-six (36) months from the documented date of startup, or ten thousand (10,000) hours of use, whichever occurs first. Supplier’s repair or replacement of any Product shall not extend the period of any warranty of any Product. This warranty applies to the exchange of part(s) found to be defective by an Authorized Powerex Service Representative only.

(d) Replacement Pumps – Parts Only (No Labor). For any replacement Air-End or Vacuum Pumps installed on a Powerex manufactured system or unit after any initial warranty period has expired or where another warranty does not apply for any reason, Powerex warrants that the Air-End or Vacuum Pumps shall be free of Defects for a period of thirty-six (36) months from the date of shipment by Powerex or ten thousand (10,000) hours of use, whichever comes first. For any replacement Air-End or Vacuum Pumps installed on a system that was not manufactured by Powerex after any initial warranty period has expired or where another warranty does not apply for any reason, Powerex warrants that the Air-End or Vacuum Pumps shall be free of Defects for the first twelve (12) months from the date of shipment by Powerex. Supplier’s repair or replacement of any Product shall not extend the period of any warranty of any Product. This warranty applies to the exchange of part(s) found to be defective by an Authorized Powerex Service Representative only.

(e) Replacement Motors – Parts Only (No Labor). For any replacement motor installed on a Powerex manufactured system or unit after any initial warranty period has expired or where another warranty does not apply for any reason, Powerex warrants that the replacement motor shall be free of Defects for the first twelve (12) months from the date of shipment by Powerex. For any replacement motor installed on a system or unit that was not manufactured by Powerex after any initial warranty period has expired or where another warranty does not apply for any reason, Powerex warrants that the replacement motor shall be free of Defects for the first ninety (90) days from the date of shipment by Powerex. Supplier’s repair or replacement of any Product shall not extend the period of any warranty of any Product. This warranty applies to the exchange of part(s) found to be defective by an Authorized Powerex Service Representative only.

(f) Replacement Parts – Parts Only (No Labor). For other replacement parts besides motors, Air-End or Vacuum Pumps installed on a Powerex manufactured system or unit after any initial warranty period has expired or where another warranty does not apply for any reason, Pow-

Powerex warrants that such replacement parts will be free from Defects for the first twelve (12) months from the date of shipment by Powerex. For other replacement parts besides motors, Air-End or Vacuum Pumps installed on a system or unit that was not manufactured by Powerex after any initial warranty period has expired or where another warranty does not apply for any reason, Powerex warrants that such replacement parts will be free from Defects for the first twelve (12) months from the date of shipment by Powerex. For other replacement parts besides motors, Air-End or Vacuum Pumps installed on a system or unit that was not manufactured by Powerex after any initial warranty period has expired or where another warranty does not apply for any reason, Powerex makes no warranties. Supplier's repair or replacement of any Product shall not extend the period of any warranty of any Product. This warranty applies to the exchange of part(s) found to be defective by an Authorized Powerex Service Representative only.

(g) Coverage. The warranty provided herein applies to Powerex manufactured units or systems only.

(h) Exceptions. Notwithstanding anything to the contrary herein, Powerex shall have no warranty obligations with respect to Products:

- (i)** That have not been installed in accordance with Powerex's written specifications and instructions;
- (ii)** That have not been maintained in accordance with Powerex's written instructions;
- (iii)** That have been materially modified without the prior written approval of Powerex; or
- (iv)** That experience failures resulting from operation, either intentional or otherwise, in excess of rated capacities or in an otherwise improper manner.

The warranty provided herein shall not apply to: **(i)** any defects arising from corrosion, abrasion, use of insoluble lubricants, or negligent attendance to or faulty operation of the Products; **(ii)** ordinary wear and tear of the Products; or **(iii)** defects arising from abnormal conditions of temperature, dirt or corrosive matter; **(iv)** any OEM component which is shipped by Powerex with the original manufacturer's warranty, which shall be the sole applicable warranty for such component.

Limitation of Liability. NOTWITHSTANDING ANYTHING TO THE CONTRARY HEREIN, TO THE EXTENT ALLOWABLE UNDER APPLICABLE LAW, UNDER NO CIRCUMSTANCES SHALL POWEREX BE LIABLE FOR ANY INCIDENTAL, CONSEQUENTIAL, PUNITIVE, SPECULATIVE OR INDIRECT LOSSES OR DAMAGES WHATSOEVER ARISING OUT OF OR IN ANY WAY RELATED TO ANY OF THE PRODUCTS OR GOODS SOLD OR AGREED TO BE SOLD BY POWEREX TO BUYER. TO THE EXTENT ALLOWABLE UNDER APPLICABLE LAW, POWEREX'S LIABILITY IN ALL EVENTS IS LIMITED TO, AND SHALL NOT EXCEED, THE PURCHASE PRICE PAID.

Warranty Disclaimer. Powerex has made a diligent effort to illustrate and describe the Products in its literature, including its Price Book, accurately; however, such illustrations and descriptions are for the sole purpose of identification, and do not express or imply a warranty that the Products are merchantable, or fit for a particular purpose, or that the Products will necessarily conform to the illustrations or descriptions.

Product Suitability. Many jurisdictions have codes and regulations governing sales, construction, installation, and/or use of Products for certain purposes, which may vary from those in neighboring areas. While Powerex attempts to assure that its Products comply with such codes, it cannot guarantee compliance, and cannot be responsible for how the product is installed or used. Before purchase and use of a Product, please review the Product applications, and national and local codes and regulations, and be sure that the Product, installation, and use will comply with them.

Claims. Any non-warranty claims pertaining to the Products must be filed with Powerex within 6 months of the invoice date, or they will not be honored. Prices, discounts, and terms are subject to change without notice or as stipulated in specific Product quotations. Powerex shall not be liable for any delay or failure arising out of acts of the public enemy, fire, flood, or any disaster, labor trouble, riot or disorder, delay in the supply of materials or any other cause, whether similar or dissimilar, beyond the control of Company. All shipments are carefully inspected and counted before leaving the factory. Please inspect carefully any receipt of Products noting any discrepancy or damage on the carrier's freight bill at the time of delivery. Discrepancies or damage which obviously occurred in transit are the carrier's responsibility and related claims should be made promptly directly to the carrier. Returned Products will not be accepted without prior written authorization by Powerex and deductions from invoices for shortage or damage claims will not be allowed. **UNLESS OTHERWISE AGREED TO IN WRITING, THE TERMS AND CONDITIONS CONTAINED IN THIS LIMITED WARRANTY WILL CONTROL IN ANY TRANSACTION WITH POWEREX.** Any different or conflicting terms as may appear on any order form now or later submitted by the buyer will not control. All orders are subject to acceptance by Powerex.