

Claw Medical Vacuum Systems

Please read and save these instructions. Read carefully before attempting to assemble, install, operate or maintain the product described. Protect yourself and others by observing all safety information. Failure to comply with instructions could result in personal injury and/or property damage! Retain instructions for future reference.

Description

General

Powerex Medical Vacuum Systems are designed to provide vacuum for hospitals and medical institutes. They are designed and constructed to meet NFPA 99 requirements for Level 1 piped vacuum systems. If WAGD vacuum is the same as the medical-surgical vacuum source: Flammable anesthetics or flammable vapors shall be diluted below the flammable limit prior to disposal into the vacuum system or the pumps shall be designed of materials and using lubricants that are inert in the presence of oxygen, nitrous oxide, and halogenated anesthetics.

Safety Guidelines

This manual contains information that is very important to know and understand. This information is provided for SAFETY and to PREVENT EQUIPMENT PROBLEMS. To help recognize this information, observe the following symbols.

⚠ DANGER *Danger indicates an imminently hazardous situation which, if not avoided, WILL result in death or serious injury.*

⚠ WARNING *Warning indicates a potentially hazardous situation which, if not avoided, COULD result in death or serious injury.*

⚠ CAUTION *Caution indicates a potentially hazardous situation which, if not avoided, MAY result in minor or moderate injury.*

NOTICE *Notice indicates important information, that if not followed, may cause damage to equipment.*

NOTE: Note indicates information that requires special attention.

Unpacking

After unpacking the unit, inspect carefully for any damage that may have occurred during transit. Make sure to tighten fittings, bolts, etc., before putting unit into service.

⚠ WARNING *Do not operate unit if damaged during shipping, handling or use. Damage may result in bursting and cause injury or property damage.*

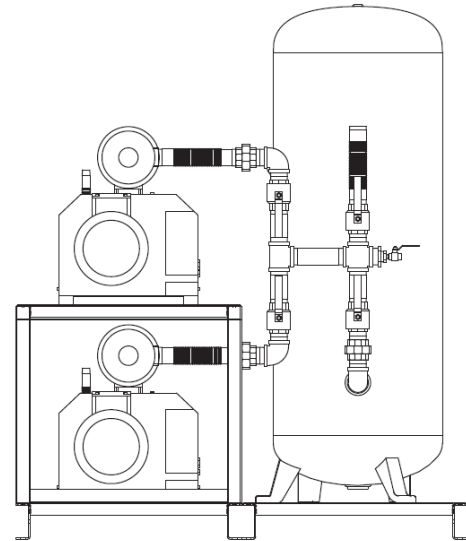

| Specifications | |
|------------------------|--|
| Product | CVTD, CVPD, CVPT, CVPQ Series |
| Operating Voltages | 208V, 230V, 460V |
| Control Panel | UL508A and NFPA compliant |
| Motor | TEFC Electric Motor |
| Tank | ASME Rated for 200 psi MAWP |
| Pump | Capable of operating at: 28.4" Hg (sea level) continuous duty for 2 HP 28.4" Hg (sea level) continuous duty for 3 HP 28.4" Hg (sea level) continuous duty for 4 HP 28.4" Hg (sea level) continuous duty for 5 HP 26.0" Hg (sea level) continuous duty for 6.4 HP 26.0" Hg (sea level) continuous duty for 7.5 HP 23.0" Hg (sea level) continuous duty for 10 HP 23.0" Hg (sea level) continuous duty for 15 HP |
| Drive | Direct |
| Tank Sizes | 80 Gallon to 240 Gallon |
| Performance | See Cut Sheet |
| Outlet Air Connections | 2 HP - 1 inch 3 HP - 1 inch 5 HP - 1 inch 6.4 HP - 1 inch 7 HP - 1 inch 9.1 HP - 1 inch 10.2 HP - 1-1/2 inch 15 HP - 3 inch |

Components

Vacuum Pumps

Powerex medical vacuum systems use electric motor driven claw type pumps to create vacuum for the removal of unwanted fluids and gases. The pumps remove the gases and exhaust them to atmosphere through the exhaust piping system.

Systems consist of multiple vacuum pumps that are automatically controlled and may be isolated using valves for service. One pump is used as the reserve. The control system will trigger alarm actions in accordance with NFPA 99 requirements if the capacity of the reserve pump is needed. The control system operates the available pumps in response to vacuum demand as determined by the vacuum switches or sensor. If needed, the controls will include minimum run timer functions to prevent frequent starting and stopping of the electric motors.

The vacuum pump assemblies are mounted with vibration isolation. Each vacuum pump has its own motor. The motors are mated to the vacuum pumps by a flange mounting and coupling system. Some models include auxiliary cooling fans. Maintenance instructions are provided for the vacuum pumps and motors in the separate manual. Each vacuum pump has an intake assembly that includes 10 micron polyester filters for each pump with a small fitting or pipe plug for releasing the vacuum and facilitating the removal of the filter covers when the pump is isolated the system is still under vacuum. Each pump has an in-line check valve and an anti-reverse flow valve to prevent them from running backwards when off. An inlet screen protects the pump from large particles entering the rotor/vane area.

Receiver Tank

The receiver tank in a Powerex Medical Vacuum System is plumbed so that it sees the system vacuum. It is not pressurized in normal use and should not be connected to any pressure sources. The ASME National Board registered air receiver is provided with a manual drain valve as standard and optional auto drain and sight tube set ups are available. Systems may be built with receivers separately mounted or with vacuum pumps and controls integrally mounted.

CAUTION *Factory installed receiver is used for vacuum capacity only and is NOT a collection receiver.*

DANGER *Never drill holes in, or perform any welding on receiver tanks (unless qualified by ASME to do so) or use them beyond the rated pressure settings. Never mount other machinery or equipment on receivers.*



Standard Control Panel

Built in a Nema 4/12 enclosure, the controls are UL508A labeled and NFPA compliant. The panels have a single incoming power connection point and two control transformers with supplementary fused protected on primary and secondary circuits. Systems are designed for automatic alternation via PLC control. Systems with two to four motors utilize field adjustable vacuum switches. Systems with five or more motors utilize a vacuum transducer. Each motor in the system is equipped with a magnetic starter and lockable motor protector circuit disconnect.

All systems have a 30 minute alternation cycle with 10 minute minimum run timers for each pump to prevent short cycling and motor damage. Additional features include:

- “Reserve Pump in Use” alarm with visual and audible indicators.
- “Reserve Transformer in Use” visual indicator.
- “Power On” light
- “Lamp Test” push button
- Audible alarm “Acknowledge” push button
- Alarm “Reset” push button
- Dry contacts on a labeled terminal strip for remote alarm connection.
- Lighted HOA switch
- Hour meter for each motor

Installation

⚠ WARNING *Disconnect, tag and lock out power source then release all pressure from the system before attempting to install, service, relocate or perform any maintenance.* 

⚠ CAUTION *Do not lift or move unit without appropriately rated equipment. Be sure the unit is securely attached to lifting device used. Do not lift unit by holding onto tubes or coolers. Do not use pumps to lift other attached equipment.*

⚠ WARNING *Installation of inlet / outlet air plumbing from the system and electrical connections must be in accordance with National Fire Protection Association (NFPA99) Code Compliance for Medical Gas Breathing Air (Level 1).*

Installation Site

1. The vacuum system must be located in a clean, well lit and well ventilated area.
2. The area should be free of excessive dust, toxic or flammable gases and moisture.
3. Never install the vacuum system where the surrounding temperature is higher than 104°F or where humidity is high.
4. Clearance must allow for safe, effective inspection and maintenance.

| MINIMUM CLEARANCES | |
|--------------------|-----------|
| Above | 24 inches |
| Other sides | 36 inches |

5. If necessary, use metal shims or leveling pads to level the system. Never use wood to shim the unit.
6. The frame is drilled to allow bolting to the floor. Secure it as necessary. Rubber composite isolation pads should be used to minimize transmission of noise and vibration to the building. Additional measures for isolation may be required. Drill a hole through the isolation pad and center it under the mounting point.
7. Some systems are built with multiple frames and must be installed and the air and electrical connections between the frames made at the time of installation. Be sure to install the system in the same configuration as shown on the system drawing so that the flexible connection hoses and electrical lines will fit.

Ventilation

1. If the vacuum system is located in a totally enclosed room, an exhaust fan with access to outside air make up air must be installed.
2. Never restrict the cooling fan exhaust air. Maintain the clearance listed above.
3. Never locate the vacuum system where hot exhaust air from other heat generating units may be pulled into the unit.

Wiring

⚠ DANGER *Lock out and tag out the electrical supply before servicing the equipment.*

⚠ DANGER *Electrical shock hazard. Make sure the system is grounded in accordance with NEC and local requirements.*



All electrical hook-ups must be performed by a qualified electrician. Installations must be in accordance with local and national electrical codes. Make sure power supply conductors are sized adequately for full system demand.

Piping

The system may have temporary shipping supports in place. These should be removed when the system piping is connected to the building piping. Appropriate supports should be added to the system when building tie in is completed.

The system has a single point inlet with a flexible connector. Each pump is supplied with a flexible connector for tying in to the system exhaust. A drip leg should be placed in the exhaust as close to the system as possible or multiple drip legs can be used at each pump exhaust connection. The drip leg must prevent collected condensation from draining back into the pump or pumps.

1. Make sure the piping is lined up without being strained or twisted when assembling the piping for the system.
2. The exhaust piping should be kept as short and have the least restriction possible. The fl ex connector supplied by Powerex may be repositioned (changed from vertical to horizontal and the elbow turned or removed) if desired to achieve a more effective installation to match the field installed exhaust piping. Repositioning is desirable if the final system plumbing design can be shorter by doing so.
3. Never use any piping smaller than the pump connection. To determine the minimum required pipe size for a vacuum system exhaust, calculate the equivalent straight length of the run. Never use a pipe size smaller than the fl ex connector supplied by Powerex or smaller than the size shown in the 100 foot column on the chart for the CFM of the pump. The equivalent straight length is the length of all the pipe needed from the fl ex connector to the final outlet plus a factor for each elbow, cross or tee. Pipe must be smooth ID. If rough pipe is used, increase by one size.
4. If a grating or grille is used at the end of the exhaust pipe, make sure its open area is at least equal to the area of the exhaust pipe.

| PIPE SIZE REQUIREMENTS | | | |
|------------------------|------------------------------|------------------------------|------------------------------|
| Systems CFM | Minimum Pipe Size for 100 ft | Minimum Pipe Size for 300 ft | Minimum Pipe Size for 600 ft |
| 5 | 1.0 | 1.25 | 1.5 |
| 7 | 1.0 | 1.25 | 1.5 |
| 11 | 1.25 | 1.5 | 1.5 |
| 21 | 1.25 | 1.5 | 1.5 |
| 26 | 1.25 | 1.5 | 2.0 |
| 32 | 1.25 | 1.5 | 2.0 |
| 38 | 1.5 | 2.0 | 2.5 |
| 52 | 1.5 | 2.0 | 2.5 |
| 58 | 1.5 | 2.5 | 2.5 |
| 63 | 2.0 | 2.5 | 2.5 |
| 65 | 2.0 | 2.5 | 3.0 |
| 87 | 2.0 | 2.5 | 3.0 |
| 104 | 2.0 | 3.0 | 3.5 |
| 111 | 2.5 | 3.0 | 3.5 |
| 154 | 2.5 | 3.0 | 3.5 |
| 156 | 2.5 | 3.5 | 4.0 |
| 168 | 2.5 | 3.5 | 4.0 |
| 195 | 3.0 | 3.5 | 4.0 |
| 258 | 3.0 | 3.5 | 4.0 |
| 260 | 3.5 | 4.0 | 5.0 |
| 387 | 3.5 | 4.0 | 5.0 |
| 516 | 4.0 | 5.0 | 6.0 |

| Approximate system CFM equals the number of pumps running times CFM in table below. (Data below is for reference only, if actual pump CFM is higher than shown, use the higher value.) | | |
|---|---------------------|---------------------|
| HP | Vane Pump CFM @ 19" | Claw Pump CFM @ 19" |
| 1.0 | 2.0 | |
| 1.5 | 7 | |
| 2.0 | 11 | 16 |
| 3.0 | 17 | 21 |
| 4.0 | | 29 |
| 5.0 | 26 | |
| 5.0 | 38 | |
| 5.4 | | 38 |
| 6.4 | | 52 |
| 7.5 | 52 | 65 |
| 8.7 | | 77 |
| 10.0 | 65 | 84 |
| 10.0 | 77 | |
| 15.0 | 111 | 129 |
| 20.0 | 137 | |
| 25.0 | 168 | |

| Pipe Size | Equivalent length for 90° elbow, cross, or tee | Equivalent length for 45° elbow |
|-----------|--|---------------------------------|
| | 3.0 ft | 1.5 ft |
| 1.5 | 3.75 ft | 1.8 ft |
| 2.0 | 5.0 ft | 2.5 ft |
| 2.5 | 6.25 ft | 3.1 ft |
| 3.0 | 7.5 ft | 3.8 ft |
| 3.5 | 8.78 ft | 4.4 ft |
| 4.0 | 10.0 ft | 5.0 ft |
| 5.0 | 12.5 ft | 6.25 ft |

Operation

Before Start Up

1. Make sure all safety warnings, labels and instructions have been read and understood before continuing.
2. Remove any shipping materials, brackets, etc.
3. Ensure all fuses, circuit breakers, etc., are properly sized.
4. Verify that all pumps have the proper amount of oil in them for operation. The claw type vacuum pumps require oil in the gear boxes. See the enclosed manual from the pump manufacturer for correct oil type to use.
5. Confirm electric power source and ground have been firmly connected. Make sure the electrical control box door is closed and latched.
6. Make sure inlet filter is properly installed and all piping is connected. Open the isolation valves for each vacuum pump. Open the valve to the receiver. Close the receiver drain valve.
7. Make sure all selector switches on the control panel are OFF.

WARNING Risk of injury. Make sure no one in contact with any moving parts during the rotation check.



8. Check that all fuses, circuit breakers, etc., are the proper size.

NOTICE If all pumps are running in the wrong direction, change the incoming power leads to correct rotation.

NOTICE On some claw vacuum pumps, the fan is powered by a separate motor. The fan rotation direction may be different from the main shaft rotation direction.

Start Up & Operation

1. Follow all procedures under “Before Start-Up” before attempting operation of the vacuum pump.
2. Make sure all selector switches are in the OFF position.
3. Switch on electric source.
4. Open tank connection valve or valves completely.
5. Using the selector switches on the control panel, turn on each pump – motor in the “Auto” mode until all are running.
6. Check the vacuum level using the system gauge or display. The control system will turn off the vacuum pump motors when the vacuum level is maintained and the minimum run timer conditions are satisfied.
7. Check for excessive vibration, unusual noises or leaks during operation. If problems are detected, shut down the system and make corrections or repairs as needed before operating the system.
8. Pumps may be operated in “Hand” mode to override the function of the automatic controls. The pumps and the system

will not be damaged during “hand” mode operation. The pumps are equipped with automatic vacuum limiting valves if needed to avoid damage.

9. In normal operation, leave all selector switches in the “Auto” position and allow the controls to cycle the pumps as needed based on vacuum demand.

NOTICE

Switch breaker OFF if vacuum pump will not be used for a long period of time.

Sequence of Operations

All vacuum pumps will operate on a ten minute minimum run timer (to prevent the short cycling of pumps) and will alternate Lead, Lag and etc. every 30 minutes, unless interrupted by the Lead / Lag Freeze (see example below.)

For example, a vacuum switch closes 25 minutes into the 30 minute alternation sequence; pump 1 is activated and held on for its ten minute minimum run time. The alternation sequence will be extended to a total of 35 minutes. During the following 30 minutes, if a vacuum switch closes, pump 2 will be activated and held on for its ten minute run time. This operation is referred as the Lead / Lag Freeze. Its purpose is to prevent short cycling of pumps in the event that a vacuum switch is activated at the end of an alternation period. The Reserve (or last Lag) Vacuum Switch will bring on the reserve or last pump in the system and activate the Reserve Pump In Use Alarm.

The Vacuum Switches are factory set to the system specifications. It is not recommended to adjust the settings in the field. An adjustment to the setting could result in inconsistent PLC operation and possible malfunction of the system controls. Please consult your service contractor if adjustments are required.

Maintenance

Lubrication

Refer to the manual from the vacuum pump manufacturer for lubrication intervals and type of oil to use. Oilless claw vacuum pumps have gear boxes that must be maintained and the gearbox oil needs to be changed at specified intervals.

NOTICE

If the gas being pumped through the vacuum system is known to be incompatible with petroleum based oils, the user must drain and refill the vacuum pumps with suitable oil before use. Failure to do so will void the warranty.

⚠ WARNING

RISK OF ELECTRIC SHOCK AND INJURY

Multiple supply sources. Always disconnect VFD and motor circuit before servicing.

Multiple pump Vacuum System controls with Variable Frequency Drive have multiple sources of supply for the electric power. To eliminate the risk of electric shock and injury while performing service on any of the pump-motors, always disconnect, lock out and tag out the main motor circuit and the VFD supply circuit. Failure to disconnect and secure both circuits could allow the pump motor to start during the service activity and may lead to electric shock and injury.

Maintenance Schedule

| Item | Action Needed | Operating Hours | | | | | | | Remarks |
|------------------|------------------|-----------------|------|------|------|-------|-------|-------|---------------------------|
| | | 500 | 2500 | 3000 | 5000 | 10000 | 15000 | 20000 | |
| Inlet air filter | Inspect, Replace | ● | ▲ | ● | | | | | Every 3,000 hours or less |
| Blower fan | Clean | | | | ● | ● | ● | ● | |
| Fan shield | Clean | | | | ● | ● | ● | ● | |
| Pump fans | Clean | | | | ● | ● | ● | ● | |
| Vacuum switch | Inspect | | | | ● | ● | ● | ● | |
| Gear oil | Inspect, Replace | | | ● | | | | ▲ | Every 3,000 hours or less |

- Inspect
- ▲ Replace

NOTES:

1. Inspect and perform maintenance periodically according to maintenance schedule.
2. The maintenance schedule relates to the normal operating conditions. If the circumstances and load condition are adverse, shorten the interval time and perform maintenance accordingly.

Troubleshooting Guide

| Problem | Cause | Corrective Action |
|------------------------|----------------------|--|
| Lag Alarm | Overload Tripped | <ol style="list-style-type: none"> 1. Reset overload; if problem continues, check motor amp draw 2. Verify overload is set to the correct service factor 3. Verify wire gauge is correct for amp draw |
| | PLC Failure | <ol style="list-style-type: none"> 1. Check PLC for red error light; replace PLC 2. Check PLC for flashing green light; if 24V DC is present on the last input, then reprogram PLC with E-Prom chip |
| | Pump / Motor Failure | <ol style="list-style-type: none"> 1. Check drive coupling; replace if needed 2. Verify that pump shaft turns freely; repair or replace as necessary 3. Check vacuum discharge piping to verify air is being exhausted; repair or replace as necessary 4. Verify voltage to the motor; repair wiring or replace motor as necessary |
| | Vacuum Consumption | <ol style="list-style-type: none"> 1. Repair leaks 2. Inspect purge valves are closing; repair or replace as necessary 3. If scroll pump is running backwards, replace check valve |
| | Switch Failure | Check continuity on lead vacuum switch |
| High Temperature Alarm | High Temperature | Verify ambient temperature is below 104 ° F |
| | Lost Connection | Inspect high temperature probe and connections; replace if necessary |

Powerex Limited Warranty – Applicable to Non-OEM Customers in the U.S. & Canada Only

Warranty and Remedies.

(a) General. Powerex warrants each Compressor System, Vacuum System, Vacuum Pump, Compressor Air-End, or Powerex branded Accessory (collectively “Products”, individually each a “Product”) to be free from defects in material and workmanship (“Defects”) at the date of shipment. This warranty shall apply only to Products that are purchased and used in the United States of America and in Canada. EXCEPT AS SET FORTH BELOW, NO OTHER WARRANTY, WHETHER EXPRESS OR IMPLIED, INCLUDING ANY WARRANTY OF MERCHANTABILITY OR FITNESS FOR A PARTICULAR PURPOSE, SHALL EXIST IN CONNECTION WITH THE SALE OR USE OF SUCH PRODUCTS. TO THE EXTENT PERMITTED BY LAW, ANY AND ALL IMPLIED WARRANTIES ARE EXCLUDED. All warranty claims must be made in writing and delivered to Powerex in accordance with the procedures set forth on its website (www.powerexinc.com), or such claim shall be barred. Upon timely receipt of a warranty claim, Powerex shall inspect the Product claimed to have a Defect, and Powerex shall repair, or, at its option, replace, free of charge, any Product which it determines to have had a Defect; provided, however, that if circumstances are such as to preclude the remedying of Defect by repair or replacement, Powerex shall, upon return of the Product, refund to buyer any part of the purchase price of such Products paid to Powerex. Freight for returning Products to Powerex for inspection shall be paid by buyer. The warranties and remedies herein are the sole and exclusive remedy for any breach of warranty or for any other claim based on any Defect, or non-performance of the Products, whether based upon contract, warranty or negligence.

(b) (i) Standard Period of Warranty – Parts and Labor. The purchase of any system includes our standard warranty. Powerex warrants and represents all Products shall be free from Defects for the first eighteen (18) months from the date of shipment by Powerex, or twelve (12) months from the documented date of startup, or five thousand (5,000) hours of use, whichever occurs first. During such warranty period, Powerex shall be fully liable for all Defects in the Products (the “Product Defects”), i.e., all costs of repair or replacement, which may include “in and out” charges, so long as the Products are located in the United States or Canada, and the Products are reasonably located and accessible by service personnel for removal. “In and out” charges include the costs of removing a Product from buyer’s equipment for repair or replacement.

(ii) Premium Period of Warranty – Parts and Labor. In order to be eligible for premium warranty coverage, a premium warranty for each system must be purchased when order is placed. Powerex warrants and represents all Products shall be free from Defects for the first thirty (30) months from the date of shipment by Powerex, or twenty-four (24) months from the documented date of startup, or seven thousand five hundred (7,500) hours of use, whichever occurs first. During such warranty period, Powerex shall be fully liable for all Defects in the Products (the “Product Defects”), i.e., all costs of repair or replacement, which may include “in and out” charges, so long as the Products are located in the United States or Canada, and the Products are reasonably located and accessible by service personnel for removal. “In and out” charges include the costs of removing a Product from buyer’s equipment for repair or replacement.

(c) Additional Period of Warranty – Parts Only (No Labor). In addition to the above, Powerex warrants each Powerex branded Compressor Air-End and Vacuum Pump shall be free of Defects for a period of forty-two (42) months from the date of shipment by Powerex, or thirty-six (36) months from the documented date of startup, or ten thousand (10,000) hours of use, whichever occurs first. Supplier’s repair or replacement of any Product shall not extend the period of any warranty of any Product. This warranty applies to the exchange of part(s) found to be defective by an Authorized Powerex Service Representative only.

(d) Replacement Pumps – Parts Only (No Labor). For any replacement Air-End or Vacuum Pumps installed on a Powerex manufactured system or unit after any initial warranty period has expired or where another warranty does not apply for any reason, Powerex warrants that the Air-End or Vacuum Pumps shall be free of Defects for a period of thirty-six (36) months from the date of shipment by Powerex or ten thousand (10,000) hours of use, whichever comes first. For any replacement Air-End or Vacuum Pumps installed on a system that was not manufactured by Powerex after any initial warranty period has expired or where another warranty does not apply for any reason, Powerex warrants that the Air-End or Vacuum Pumps shall be free of Defects for the first twelve (12) months from the date of shipment by Powerex. Supplier’s repair or replacement of any Product shall not extend the period of any warranty of any Product. This warranty applies to the exchange of part(s) found to be defective by an Authorized Powerex Service Representative only.

(e) Replacement Motors – Parts Only (No Labor). For any replacement motor installed on a Powerex manufactured system or unit after any initial warranty period has expired or where another warranty does not apply for any reason, Powerex warrants that the replacement motor shall be free of Defects for the first twelve (12) months from the date of shipment by Powerex. For any replacement motor installed on a system or unit that was not manufactured by Powerex after any initial warranty period has expired or where another warranty does not apply for any reason, Powerex warrants that the replacement motor shall be free of Defects for the first ninety (90) days from the date of shipment by Powerex. Supplier’s repair or replacement of any Product shall not extend the period of any warranty of any Product. This warranty applies to the exchange of part(s) found to be defective by an Authorized Powerex Service Representative only.

(f) Replacement Parts – Parts Only (No Labor). For other replacement parts besides motors, Air-End or Vacuum Pumps installed on a Powerex manufactured system or unit after any initial warranty period has expired or where another warranty does not apply for any reason, Pow-

Powerex warrants that such replacement parts will be free from Defects for the first twelve (12) months from the date of shipment by Powerex. For other replacement parts besides motors, Air-End or Vacuum Pumps installed on a system or unit that was not manufactured by Powerex after any initial warranty period has expired or where another warranty does not apply for any reason, Powerex warrants that such replacement parts will be free from Defects for the first twelve (12) months from the date of shipment by Powerex. For other replacement parts besides motors, Air-End or Vacuum Pumps installed on a system or unit that was not manufactured by Powerex after any initial warranty period has expired or where another warranty does not apply for any reason, Powerex makes no warranties. Supplier's repair or replacement of any Product shall not extend the period of any warranty of any Product. This warranty applies to the exchange of part(s) found to be defective by an Authorized Powerex Service Representative only.

(g) Coverage. The warranty provided herein applies to Powerex manufactured units or systems only.

(h) Exceptions. Notwithstanding anything to the contrary herein, Powerex shall have no warranty obligations with respect to Products:

- (i)** That have not been installed in accordance with Powerex's written specifications and instructions;
- (ii)** That have not been maintained in accordance with Powerex's written instructions;
- (iii)** That have been materially modified without the prior written approval of Powerex; or
- (iv)** That experience failures resulting from operation, either intentional or otherwise, in excess of rated capacities or in an otherwise improper manner.

The warranty provided herein shall not apply to: **(i)** any defects arising from corrosion, abrasion, use of insoluble lubricants, or negligent attendance to or faulty operation of the Products; **(ii)** ordinary wear and tear of the Products; or **(iii)** defects arising from abnormal conditions of temperature, dirt or corrosive matter; **(iv)** any OEM component which is shipped by Powerex with the original manufacturer's warranty, which shall be the sole applicable warranty for such component.

Limitation of Liability. NOTWITHSTANDING ANYTHING TO THE CONTRARY HEREIN, TO THE EXTENT ALLOWABLE UNDER APPLICABLE LAW, UNDER NO CIRCUMSTANCES SHALL POWEREX BE LIABLE FOR ANY INCIDENTAL, CONSEQUENTIAL, PUNITIVE, SPECULATIVE OR INDIRECT LOSSES OR DAMAGES WHATSOEVER ARISING OUT OF OR IN ANY WAY RELATED TO ANY OF THE PRODUCTS OR GOODS SOLD OR AGREED TO BE SOLD BY POWEREX TO BUYER. TO THE EXTENT ALLOWABLE UNDER APPLICABLE LAW, POWEREX'S LIABILITY IN ALL EVENTS IS LIMITED TO, AND SHALL NOT EXCEED, THE PURCHASE PRICE PAID.

Warranty Disclaimer. Powerex has made a diligent effort to illustrate and describe the Products in its literature, including its Price Book, accurately; however, such illustrations and descriptions are for the sole purpose of identification, and do not express or imply a warranty that the Products are merchantable, or fit for a particular purpose, or that the Products will necessarily conform to the illustrations or descriptions.

Product Suitability. Many jurisdictions have codes and regulations governing sales, construction, installation, and/or use of Products for certain purposes, which may vary from those in neighboring areas. While Powerex attempts to assure that its Products comply with such codes, it cannot guarantee compliance, and cannot be responsible for how the product is installed or used. Before purchase and use of a Product, please review the Product applications, and national and local codes and regulations, and be sure that the Product, installation, and use will comply with them.

Claims. Any non-warranty claims pertaining to the Products must be filed with Powerex within 6 months of the invoice date, or they will not be honored. Prices, discounts, and terms are subject to change without notice or as stipulated in specific Product quotations. Powerex shall not be liable for any delay or failure arising out of acts of the public enemy, fire, flood, or any disaster, labor trouble, riot or disorder, delay in the supply of materials or any other cause, whether similar or dissimilar, beyond the control of Company. All shipments are carefully inspected and counted before leaving the factory. Please inspect carefully any receipt of Products noting any discrepancy or damage on the carrier's freight bill at the time of delivery. Discrepancies or damage which obviously occurred in transit are the carrier's responsibility and related claims should be made promptly directly to the carrier. Returned Products will not be accepted without prior written authorization by Powerex and deductions from invoices for shortage or damage claims will not be allowed. **UNLESS OTHERWISE AGREED TO IN WRITING, THE TERMS AND CONDITIONS CONTAINED IN THIS LIMITED WARRANTY WILL CONTROL IN ANY TRANSACTION WITH POWEREX.** Any different or conflicting terms as may appear on any order form now or later submitted by the buyer will not control. All orders are subject to acceptance by Powerex.