

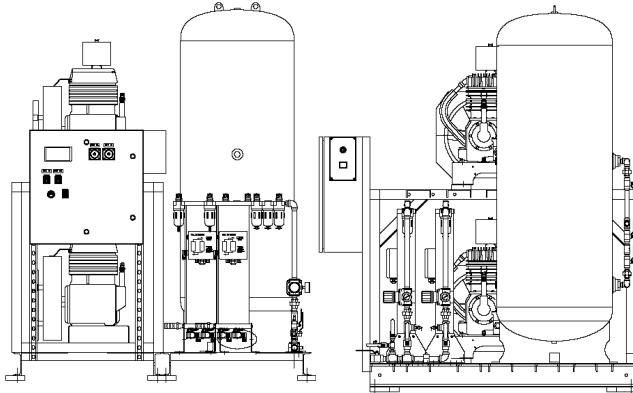

Instrument Air Package System

Please read and save these instructions. Read carefully before attempting to assemble, install, operate or maintain the product described. Protect yourself and others by observing all safety information. Failure to comply with instructions could result in personal injury and/or property damage! Retain instructions for future reference. Please refer to safety manual IN258200AV for additional important safety information..



DESCRIPTION

The Powerex instrument air package is designed to provide instrument air for hospitals and medical institutes. This system meets NFPA99 requirements for Instrument Air.

PRESSURE LUBRICATED COMPRESSOR

The reciprocating compressor is provided in duplex, triplex or quadplex configurations. Pressure lubricated technology provides reliability for years to come.

RECEIVER TANK

The ASME, National Board registered air receiver is provided in sizes from 120 to 240 gallons. Each receiver is rated at 250 PSIG working pressure. Receivers are provided with sight glass and moisture drain (manual and electric).

CONTROL PANEL

The NEMA 12 control panel complies with NFPA 99 requirements for Instrument Air. The controls operate the duplex, triplex, or quadplex 250 psi capable air compressor modules as needed in response to a pressure signal from pressure switches or a pressure transducer depending on the model. The individual unit wiring diagrams show which pressure sensing device is used.

Table of Contents			
Specifications	Pg 1, 9	Electrical	Pg 8
Installation	Pg 3-4	Parts Lists	Pg 11
Operation	Pg 4-7	Warranty	Pg 15-16
Maintenance	Pg 10		

SPECIFICATIONS

Product	Instrument Air Package Units (IPD, IPT, IPQ)
Performance Specifications	See page 9
California Ordinance 462 (L) (2)	Meets Requirements of this Ordinance
Compression Cycle	Reciprocating
Control Enclosure	NEMA 12
Control Panel	NFPA99 Level 1, UL Listed
Dew Point Capability	-40° F Pressure Dew Point at 200 psig
Drive	V-Belt
Est. Weight	See Specification sheet
Lubrication	Pressure Lubricated
Minimum Recommended Tank Sizes	See Specification Chart, pg. 9
Motor	ODP Enclosure
Motor Overload Protection	Motor Protector with Adjustable Overload
Operating Pressure	200-220
Operating Temperature	34-104° F
Operating Voltages	208/230/460 60Hz
Outlet Air Connections	1/2, 3/4 NPT
Overpressure Protection	Factory Set ASME safety valves
Power	See specification chart, pg. 9
Power Requirements	60 Hz
Pressure Setting Working Pressure	Duplex: Lead 200-220, Reserve 195-215 Triplex: Lead 203-220, Lag 1 200-217, Reserve 195-214 Quad: Lead 206-220, Lag 1 203-217 Lag 2 200-214, Reserve 195-211
Pump	5, 7.5 HP, PL15A; 10 HP, PL30A
Tank	Internally Lined ASME Rated 250 PSI
Tank Isolation	Yes
Tank Sizes	120, 200, 240
Unit Isolation	Yes
Base Unit Isolation	Yes

Instrument Air Package System

CONTROL PANEL (Cont.)

The pressure signals from the main air line are inputs to the programmable logic controller (PLC) or time alternating circuit and it is designed to operate one, two, or three compressor modules as needed to maintain the system minimum pressure of 200 psig. A reserve pump in use alarm circuit provides local indicator light and audible alarm along with remote indication if the air demand increases beyond the system rated capacity or the pressure drops for any other reason and the reserve compressor module is ever called for. An acknowledge button is provided for use during start up and maintenance.

The control will alternate or cycle which compressor module is running every ten minutes to equalize run time on all compressor modules and synchronize maintenance intervals. Two 110 v control circuit transformers with primary and secondary fuses are installed with a reserve transformer in use indicator light.

Motor circuit breakers with lockable disconnects, on/off/ auto switches, run lights, power on lights, hour meters and high temperature indicator lights and remote alarm contacts are provided for each compressor module.

DEW POINT MONITOR

The Powerex dewpoint monitor provides indication of dew point and temperature. It's microprocessor controlled with user programmable output range, alarm and calibration. The NEMA enclosure includes a polymer viewing cover.

AIR COOLED AFTERCOOLER

Beltguard aftercoolers are installed on each pump module to assure the lowest approach temperatures.

DESICCANT AIR DRYER

The Powerex desiccant air drying system provides -40°F dew point air @200 psi. Each dual desiccant dryer system consists of 2 complete desiccant dryers. Each dryer is to be switched ON and OFF LINE each six months because of service requirements, to prolong the dryer life cycle and to provide redundant back-up.

The regenerative desiccant dryer operates with two (dual) towers filled with desiccant. Each tower is switched on and off stream and is then regenerated. Dry purge air pulls moisture from the desiccant and carries the moisture out of the tower.

MEDICAL FILTER SYSTEM

The medical filter system consists of a duplex series of filters and pressure regulators. Air enters the system and is directed to either bank of filters controlled by the ball valve. The first stage filter removes solids and liquid particles. The next stage of filters remove submicronic particles and aerosols. The third filter is carbon activated to remove unpleasant odors and oil vapors. A Maximum operating temperature is 125°F and maximum pressure is 232 PSIG. The final filter is a 0.01m with pressure drop indicator.

CONDENSATE DRAIN VALVE

A condensate drain valve is installed on all tanks. This valve removes liquid that collects during compressor operation.

Drain liquid from tank daily.

SAFETY GUIDELINES

A SEPARATE SAFETY BOOKLET IS PROVIDED ALONG WITH THIS MANUAL. READ AND UNDERSTAND THE SAFETY BOOKLET. This manual contains information that is very important to know and understand. This information is provided for SAFETY and to PREVENT EQUIPMENT PROBLEMS. To help recognize this information, observe the following symbols. MAKE SURE EVERYONE OPERATING OR SERVICING THE COMPRESSOR READS AND UNDERSTANDS ALL THE INFORMATION PROVIDED.

⚠ DANGER

Danger indicates and imminently hazardous situation which, if not avoided, WILL result in death or injury.

⚠ WARNING

Warning indicates a potentially hazardous situation which, if not avoided, COULD result in death or serious injury.

⚠ CAUTION

Caution indicates a potentially minor or moderate injury.

NOTICE

Notice indicates important information, that if not followed, may cause damage to equipment.

CALIFORNIA PROPOSITION 65

⚠ WARNING

This product or its power cord may contain chemicals known to the State of California to cause cancer and birth defects or other reproductive harm. Wash hands after handling.

INSTALLATION

UNPACKING

RECEIVING THE UNIT

Immediately upon receipt of this compressor system, inspect for any damage which may have occurred during shipment.

The compressor nameplate should be checked to verify the correct model and voltage as ordered.

⚠WARNING DO NOT OPERATE UNIT IF DAMAGED DURING SHIPPING, HANDLING, OR USE. DAMAGE MAY RESULT IN BURSTING AND CAUSE INJURY OR PROPERTY DAMAGE.

INSTALLATION SITE

1. The compressor must be located in a clean, well lit and **well ventilated** area.
2. The area should be free of excessive dust, toxic or flammable gases and moisture.
3. Never install the compressor where the surrounding temperature is higher than 104°F or where humidity is high.
4. Clearance must allow for safe, effective inspection and maintenance.

Minimum Clearances	
Above	24"
Other Sides	36"

5. If necessary, use metal shims or leveling pads to level the compressor. Never use wood to shim the compressor.

VENTILATION

1. If the compressor is located in a totally enclosed room, an exhaust fan with access to outside air must be installed.
2. Never restrict the cooling fan exhaust air. Maintain a minimum of 3 feet of clearance around the entire unit.
3. Never locate the compressor where hot exhaust air from the other heat generating units may be pulled into the unit.

WIRING

All electrical hook-ups must be performed by a qualified electrician. Installations must be accordance with local and national electrical codes. Use solderless terminals to connect the electric power source.

PIPING

Refer to the general product manual.

1. Make sure the piping is lined up without being strained or twisted when assembling the piping for the compressor.
2. Appropriate expansion loops or bends should be installed at the compressor to avoid stresses caused by changes in hot and cold conditions.
3. Piping supports should be anchored separately from the compressor to reduce noise and vibration.
4. Never use any piping smaller than the compressor connection.
5. Use flexible hose to connect the outlet of the compressor to the piping so that the vibration of the compressor does not transfer to the piping.

SAFETY VALVES

Compressors are shipped from the factory with the safety valves installed in the tank. The flow capacity of the safety valve is equal to or greater than the capacity of the compressor.

1. The pressure setting of the safety valve must be no higher than the maximum working pressure of the tank.
2. Safety valves should be placed ahead of any possible blockage point in the system, i.e. shutoff valve.
3. Avoid connecting the safety valve with any tubing or piping.
4. Manually operate the safety valve every six months to avoid sticking or freezing.

ASSEMBLING MODULAR INSTRUMENT AIR SYSTEM:

MODULAR PLACEMENT

1. Unpack each module and discard all wood shipping materials.
2. Locate the frame assembly fasteners provided in parts pack [includes: fasteners, filter(s) isolation pads and inlet flex line].
3. Place modules at location designated (see picture on Pg 5 for proper arrangement of modules). Provide sufficient clearance around unit for servicing (see minimum clearance section).
4. Install frame assembly fasteners to each frame joining the frames together.
5. Lift corners of each frame assembly and install isolation pads provided.

NOTE: Remove shipping brackets (painted orange or tagged) located at the base plate of each compressor module. This will allow spring isolators to free up reducing noise and vibration of the unit.

Instrument Air Package System

INSTALLATION (Cont'd)

CONNECTING PIPING

1. Locate connection for piping at rear of unit for compressors module to receiver tank module.
 2. Remove plastic caps that protect piping against contamination.
 3. Connect flex joint to frame securely making sure flex line is not pinched or kinked.
- NOTE:** All piping is provided and sealed for this portion of installation.
4. Connect outlet source from filter package located on dryer module to outlet source piping.

⚠WARNING

Attach all outlet piping in accordance with NFPA 99.

ELECTRICAL WIRING OF MODULES

⚠CAUTION

Provide electrical power in accordance to NEC and local codes. Connection of wiring should be performed by a qualified electrician.

1. Connect wiring and flex conduit provided from each motor junction box to correct hole in bottom of control panel and starter.
 2. Connect each temperature switch from the compressors to contacts located in control panel as marked for each temperature switch. Temperature switches shutdown the compressor when temperature after the aftercooler is above 175°.
 3. Connect wiring from Dew Point Monitor. A wire set is provided for power and the other for alarm. Wiring is marked for easy attachment.
 4. Dryer(s) need a separate properly protected power supply for each dryer. Standard voltage is 110 Volts. Other voltages are available. Check for voltage of dryer supplied and current rating provided on data plate of dryer.
- NOTE:** All units are provided with desiccant drying systems and are wired directly to the control panel provided.

For questions concerning assembling and start-up, contact Powerex at 1-888-769-7979 for technical assistance.

OPERATION

Powerex Instrument Air Package Systems operate at a maximum pressure of 250 PSIG. Compressor RPM's are established by Powerex based on horsepower and operating pressure.

BEFORE START UP

1. Make sure all safety warnings, labels and instructions have been read and understood before continuing.
2. Remove any shipping materials, brackets, etc.
3. Confirm that the electric power source and ground have been firmly connected.
4. Check the belts for tightness.
5. Be sure all pressure connections are tight.
6. Check to be certain all safety relief valves etc., are the proper size and are correctly installed.
7. Securely mount all panels and guards.
8. Check that all fuses, circuit breakers etc., are the proper size.
9. Make sure the inlet filter is properly installed.

START-UP AND OPERATION

1. Follow all the procedures under "BEFORE START UP" before attempting operation of the compressor.
2. Make sure that all fusible disconnects and all HOA selector switches are in the OFF position.
3. Make sure all basemount isolation valves are open. Make sure the tank isolation valves are positioned so air flows through the tank and it is not by-passed. Make sure all dryer valves are open and the outlet valve after the purification system and the facility is closed.
4. Switch on the electric source.
5. Verify the HMI display screen is lit. The System Status screen should be visible.
6. Turn all fusible/breaker disconnects to the on position. Low pressure alarm will sound. Silence the alarm by pushing the acknowledge function (button labeled ACKN).
7. Jog each compressor in the manual position on the selector switch to check for rotation (clockwise if facing opposite the beltguard and counterclockwise if facing the compressor flywheel.) If the rotation is incorrect, have a qualified electrician correct the motor wiring.
8. Set all HOA selector switches to the auto position. Compressors will run until the lead pressure setting is met.
9. Check for leaks at all connections.
10. Allow the compressor system to run. Each compressor/ motor will automatically turn off as the pressure rises and the maximum operating pressure is reached. Check the transducer display and tank gauge pressures to verify.
11. One dryer should be on-line and set in the on position. The second dryer/purification system should be isolated using the ball valves provided.
12. The dew point monitor should be on and the sampling valves open.
13. Open the isolation valve after the purification

Instrument Air Package System

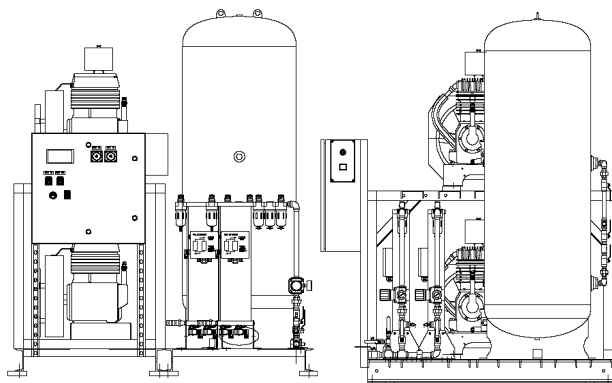

Proper Arrangement of Modules

OPERATION (Cont'd)

systems and the facility piping. The compressor will start and stop each pump as needed to maintain the pressure between the high and low set points.

14. After a few hours and again after a few days, check the display screen to see if the ALARM screen has appeared. If a HIGH TEMPERATURE or MOTOR OVERLOAD condition occurs, the alarm screen will appear and the affected pump-motor will be taken out of service.

STOPPING THE COMPRESSOR DURING NORMAL OPERATION

1. Close the discharge or isolation valve.
2. Allow the air pressure to build and the compressor to stop.

STOPPING THE COMPRESSOR DURING EMERGENCY OPERATION

Stop the compressor by turning the power off at the main disconnect panel.

CONTROL PANEL - DISPLAY AND INPUT

The Powerex Instrument Air System has a touch screen HMI panel on the front to allow operation and monitoring of the unit. See Controls section for details on operating the unit using the touch screen.

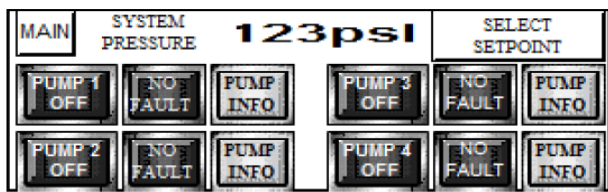

If the System Status screen is not visible, go back to the MAIN screen and select System Status. (see below)



INITIAL START UP AND SET UP OF THE CONTROL

The control system is programmed at the factory and default settings are installed. To access all the control functions you may need to enter a seven digit authorization code. You may select your own code, but we recommend using the last seven digits of the unit serial number. The following screens display a quadplex system. For a duplex system, the buttons for pumps 3 and 4 are grayed out. For a triplex system, the buttons for pump 4 are grayed out.

To enter the code, from the main menu, select SYSTEM SETPNTS.

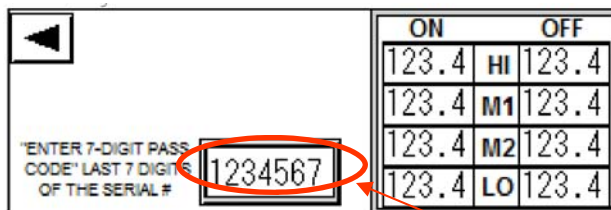

Touch the rectangle to enter the Authorization Code and enter seven digits using the keypad that appears. Powerex suggests using the last seven digits of the serial number. You may now return to the SYSTEM STATUS screen.

Instrument Air Package System

OPERATION (Cont'd)

OPERATING PANEL & SETTINGS

The Instrument Air Compressor System is controlled by a PLC programmed at the Powerex factory. The operating status is displayed on the HMI—Touch Screen panel on the front of the compressor unit. The touch screen allows the user to view system functions and set points set at the factory. The touch screen also allows the user to navigate through the screens to get more information about the operation of the individual compressor modules and to take action based on alarms and warnings. The Instrument Air Compressor System utilizes a PLC for alternation and will change the pump sequence (Lead, Lag1, Lag2, etc.) after every start or after 10 minutes, whichever happens first. The HMI displays individual pump set points. These are not field adjustable.

ALARM SIGNALS

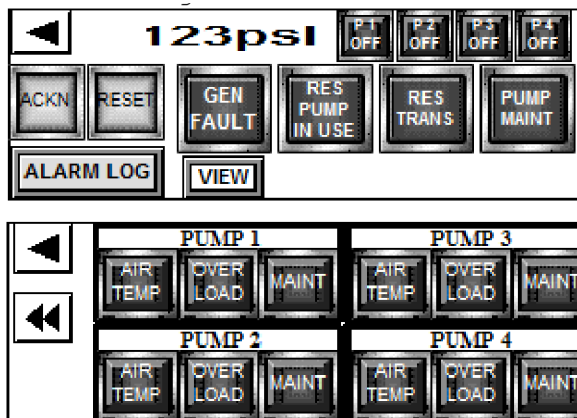

The touch screen HMI will automatically default to the ALARM screen when any alarm occurs. The alarm screen will display the active alarm which must be ACKNOWLEDGED (by pushing the button marked ACKN) before navigating to other system screens. By pressing ACKN, the local audible alarm will also be silenced. All alarms initiate a local audible and visual indicator and will de-energize the General Fault dry contacts for remote monitoring. The dry contacts are energized (closed) under a NO-ALARM condition. The touch screen HMI will display the ALARM screen and activate the GENERAL FAULT indicator on the alarm screen display (pressing the “view” button will display the actual pump in alarm) if any of the following conditions occur:

1. **High Temperature:** Each compressor has a high temperature switch located at the after cooler. This alarm will result in the “call for” signal to that motor

being disabled. The alarm must be acknowledged by pushing the ACKN button and manually reset after the condition causing the alarm has been resolved. The pump will not return to the operating sequence until it has been reset. If a high temperature condition occurs the reason should be determined and corrected before attempting to reset the alarm as un-repairable damage could result from the operation of the system with repeated high temperature alarms.

2. **Motor Overload:** Should the current to the motor exceed the setting of the adjustable motor protector, the trip mechanism will open the contacts, de-energize the starter coil and signal the controller. This alarm will result in the “call for” signal to that motor being disabled. The alarm must be acknowledged by pushing the ACKN button and manually reset after the condition causing the alarm has been resolved. The pump will not return to the operating sequence until it has been reset. In addition to the control reset, a mechanical reset must be performed at the motor protector.

OTHER ALARMS

Reserve Pump in Use: Should the last pump in the system be brought on, this alarm will be activated. This alarm must be acknowledged by pushing the ACKN button and be reset.

Reserve Transformer in Use: Should the main control circuit transformer fail, the backup transformer will immediately provide control voltage to the system. This will result in a visual alarm indication. This alarm must be acknowledged by pushing the ACKN button, but will automatically reset when the main transformer is returned to operation.

Pump Maintenance: Should a pump accumulate running hours to a required maintenance interval, this indicator will be activated. Acknowledge the alarm by pushing the ACKN button and navigate to the “System Status” screen. Next, press the “Pump Info” button for the pump in alarm to display the “Pump Monitor Screen” and verify the scheduled maintenance counter is “0”. Consult the operator’s manual for details of what maintenance needs to be performed. To reset the “PUMP MAINT” indicator, use the keypad display to enter the authorization code when prompted.

OPERATION (Cont'd)

SCREENS FOR RESETTING MAINTENANCE INDICATOR

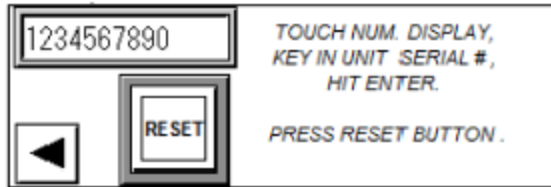

OTHER INFORMATION DISPLAYS

ALARM LOG

A record of all alarm or warning events is kept in the alarm log. Reset status is tracked as well. The alarm log is maintained as long as the unit is powered and for up to three days after power is removed from the control. See below for an example of the alarm log display screen.

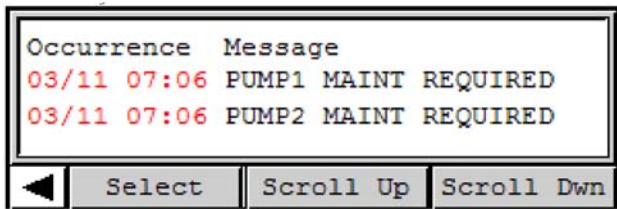

The following additional information is available by selecting the SYSTEM TRENDS from the MAIN screen:

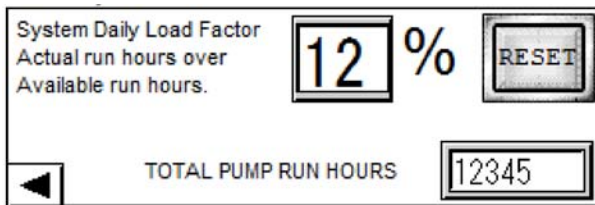

The control tracks the amount of time the pumps are in use and compares that to the available time. The ratio is displayed. The LOAD FACTOR is displayed for the most recent 24 hour period.

FAIL-SAFE FEATURES

There are a number of other fail-safe features installed on the control panel with the HMI screen. There is a door-mounted Acknowledge / Silence push button, a HOA switch per pump, and a back-up pressure switch circuit.

Instrument Air Package System

INSTRUMENT AIR FLOW SCHEMATIC

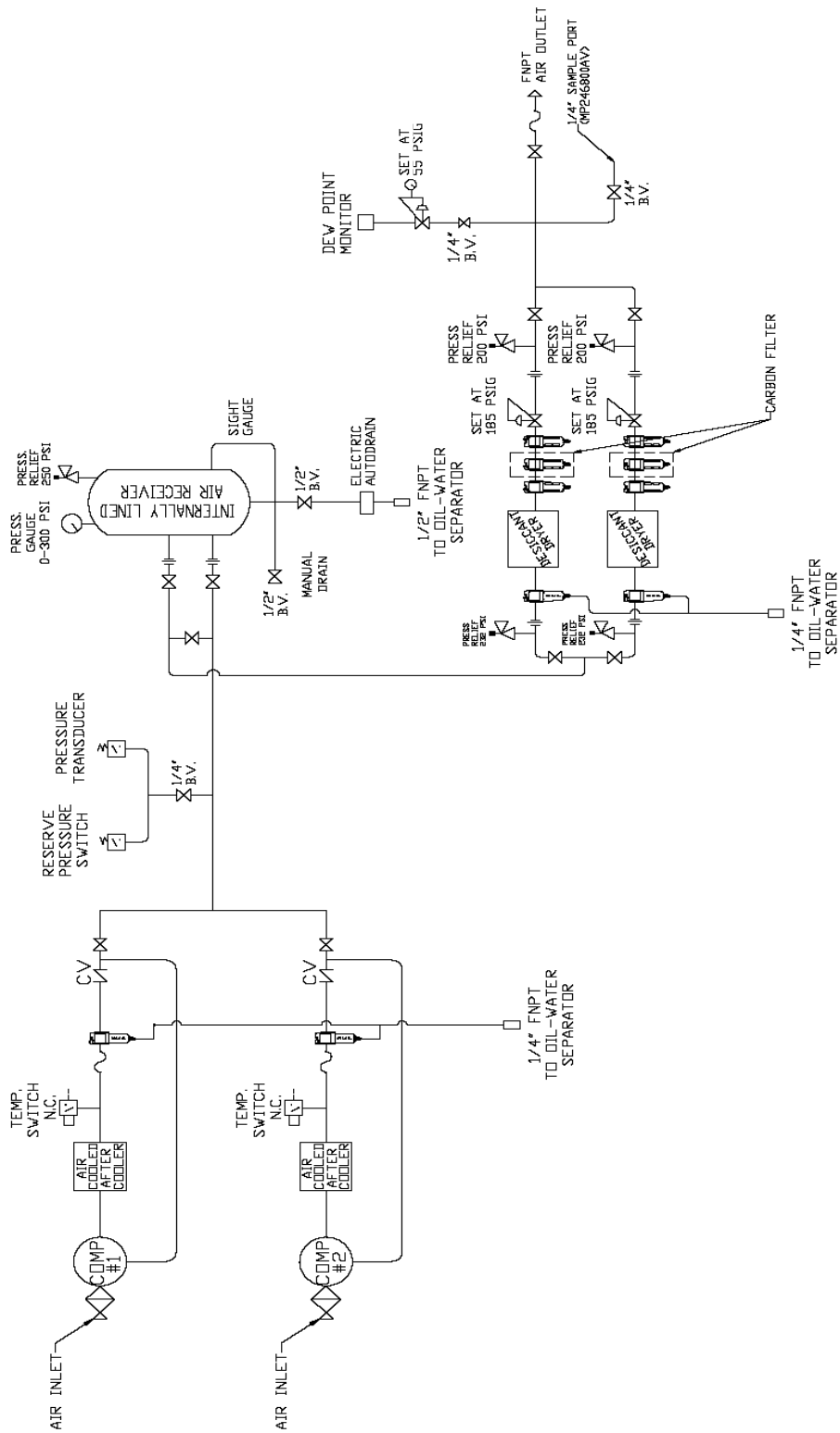

Instrument Air Package System

Specifications

Instrument Air Package Duplex-IPD

MODEL	HP	PHASE	SCFM @ 250 PSI	RPM	VOLTAGE	SYSTEM FLA	TANK (GAL.)	DIMENSIONS LXWXH (")	SHIPPING WT. (LBS)
IPD0504	5(2)	3	13.6	640	208/230/460	33/31/16	120	66X63X79	1794
IPD0754	7.5(2)	3	18.2	870	208/230/460	45/42/22	120	66X63X79	1888
IPD1004	10(2)	3	27.5	640	208/230/460	60/56/29	120	66X63X79	2470

Instrument Air Package Triplex-IPT

MODEL	HP	PHASE	SCFM @ 250 PSI	RPM	VOLTAGE	SYSTEM FLA	TANK (GAL.)	DIMENSIONS LXWXH (")	SHIPPING WT. (LBS)
IPT0504	5(3)	3	27.2	640	208/230/460	49/45/24	120	66X95X79	2539
IPT0754	7.5(3)	3	36.4	870	208/230/460	67/62/32	120	66X95X79	2828
IPT1005	10(3)	3	55.0	640	208/230/460	89/82/42	200	66X95X79	3772

Instrument Air Package Quadplex-IPQ

MODEL	HP	PHASE	SCFM @ 250 PSI	RPM	VOLTAGE	SYSTEM FLA	TANK (GAL.)	DIMENSIONS LXWXH (")	SHIPPING WT. (LBS)
IPQ0504	5(4)	3	40.8	640	208/230/460	64/59/31	120	66X126X79	3205
IPQ0755	7.5(4)	3	54.6	870	208/230/460	89/82/42	200	66X126X84	3608
IPQ1006	10(4)	3	82.5	640	208/230/460	118/109/56	240	66X126X95	4774

NOTE: SCFM listed is with one pump in reserve.

NOTE: For actual FLA/motor values, please contact factory.

Instrument Air Package System

MAINTANANCE SCHEDULE

Item	Action Needed	Operating Hours						Remarks
		500	2500	5000	10000	15000	20000	
Tank	Drain moisture	Daily	2500					
Inlet air filter	Replace	●	▲	▲	▲	▲	▲	Replace every 2,500 hrs. or less
Compressor Fins	Clean		●					Clean every 2,500 hrs. or less
V-belt	Inspect, Replace	*Note 3	●	▲	▲	▲	▲	
Safety belt	Confirm Operation		●					(Every 2,500 hrs. or less)
Pressure gauge	Inspect		●					(Every 2,500 hrs. or less)
Air leaks	Inspect		●		●		●	
Dryer filters	Replace		▲	▲	▲	▲	▲	(View delta pressure indication)
Moisture Drain traps	Inspect	●		●		●		
Heat exchanger		●	●	●	●	●		
Dryers	Alternate Monthly							

● Inspect
▲ Replace

NOTES:

1. Inspect and perform maintenance periodically according to the maintenance schedule.
2. The maintenance schedule relates to the normal operating conditions. If the circumstances and load condition are adverse, shorten the cycle time and perform maintenance accordingly.
3. The tension of the V-belt should be adjusted during the initial stage and inspected every 1,500 hours afterwards. Check base mount manual for proper belt tension.
4. Check base mount manual for proper pump maintenance schedule.
5. Check dryer manual for proper dryer maintenance schedule.

Instrument Air Package System

Unit Parts List

Ref. No.	Description	Part Number	Qty.
1	Compressor Pump:		
	5HP	PL15A	1
	7-1/2 HP	PL15A	1
	10 HP	PL30A	1
2	Corrosion Resistant Vertical Tank	Consult factory for number	1
	120 Gal.	Consult factory for number	1
	200 Gal.	Consult factory for number	1
	240 Gal.	Consult factory for number	1
3	Dew Point Monitor/Probe Desiccant	PDPM1001AJL	1
4	Safety Relief Valve	Consult factory for number	1
5	Control Panel	Consult factory for parts and availability. Call 1-888-769-7979	
6	Pressure Gauge	Consult factory for number	1
7	Auto Tank Drain Electric	AC0300100	1
8	Spring Mounts	Consult factory for parts and availability. Call 1-888-769-7979	
9	Isolation Mounts	Consult factory for parts and availability. Call 1-888-769-7979	
10	Desiccant Dryer	Consult factory for parts and availability. Call 1-888-769-7979	
11	Temperature Switch (one per pump)	AM003018AV	1 (per pump)

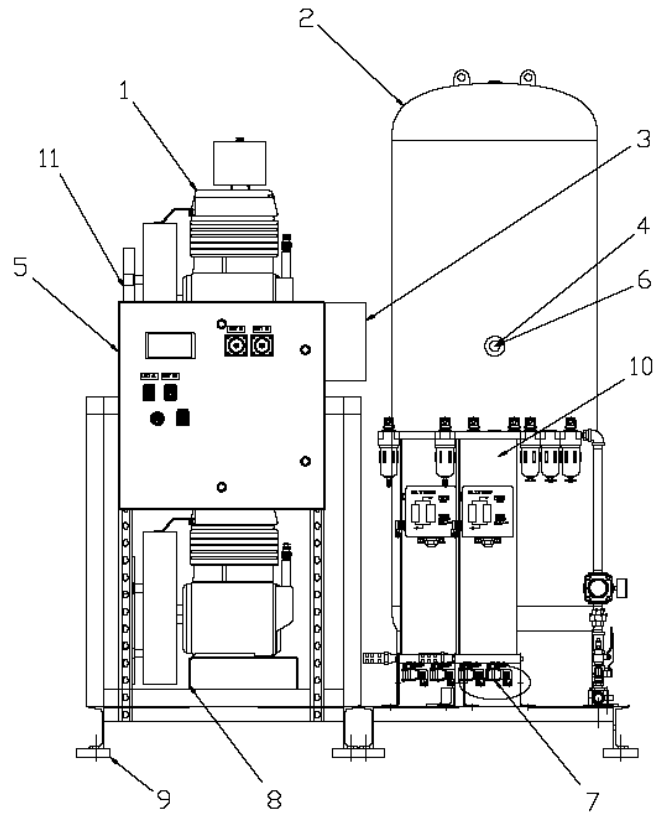

Powerex Limited Warranty – Applicable to Non-OEM Customers in the U.S. & Canada Only

Warranty and Remedies. (a) General. Powerex warrants each Compressor System, Vacuum System, Vacuum Pump, Compressor Air-End, or Powerex branded Accessory (collectively “Products”, individually each a “Product”) to be free from defects in material and workmanship (“Defects”) at the date of shipment. This warranty shall apply only to Products that are purchased and used in the United States of America and in Canada. **EXCEPT AS SET FORTH BELOW, NO OTHER WARRANTY, WHETHER EXPRESS OR IMPLIED, INCLUDING ANY WARRANTY OF MERCHANTABILITY OR FITNESS FOR A PARTICULAR PURPOSE, SHALL EXIST IN CONNECTION WITH THE SALE OR USE OF SUCH PRODUCTS. TO THE EXTENT PERMITTED BY LAW, ANY AND ALL IMPLIED WARRANTIES ARE EXCLUDED.** All warranty claims must be made in writing and delivered to Powerex in accordance with the procedures set forth on its website (www.powerexinc.com), or such claim shall be barred. Upon timely receipt of a warranty claim, Powerex shall inspect the Product claimed to have a Defect, and Powerex shall repair, or, at its option, replace, free of charge, any Product which it determines to have had a Defect; provided, however, that if circumstances are such as to preclude the remedying of Defect by repair or replacement, Powerex shall, upon return of the Product, refund to buyer any part of the purchase price of such Products paid to Powerex. Freight for returning Products to Powerex for inspection shall be paid by buyer. The warranties and remedies herein are the sole and exclusive remedy for any breach of warranty or for any other claim based on any Defect, or non-performance of the Products, whether based upon contract, warranty or negligence.

(b) (i) Standard Period of Warranty – Parts and Labor - The purchase of any system includes our standard warranty. Powerex warrants and represents all Products shall be free from Defects for the first eighteen (18) months from the date of shipment by Powerex, or twelve (12) months from the documented date of startup, or five thousand (5,000) hours of use, whichever occurs first. During such warranty period, Powerex shall be fully liable for all Defects in the Products (the “Product Defects”), i.e., all costs of repair or replacement, which may include “in and out” charges, so long as the Products are located in the United States or Canada, and the Products are reasonably located and accessible by service personnel for removal. “In and out” charges include the costs of removing a Product from buyer’s equipment for repair or replacement.

(ii) Premium Period of Warranty – Parts and Labor - In order to be eligible for premium warranty coverage, a premium warranty for each system must be purchased when order is placed. Powerex warrants and represents all Products shall be free from Defects for the first thirty (30) months from the date of shipment by Powerex, or twenty-four (24) months from the documented date of startup, or seven thousand five hundred (7,500) hours of use, whichever occurs first. During such warranty period, Powerex shall be fully liable for all Defects in the Products (the “Product Defects”), i.e., all costs of repair or replacement, which may include “in and out” charges, so long as the Products are located in the United States or Canada, and the Products are reasonably located and accessible by service personnel for removal. “In and out” charges include the costs of removing a Product from buyer’s equipment for repair or replacement.

(c) Additional Period of Warranty – Parts Only (No Labor). In addition to the above, Powerex warrants each Powerex branded Compressor Air- End and Vacuum Pump shall be free of Defects for a period of forty-two (42) months from the date of shipment by Powerex, or thirty-six (36) months from the documented date of startup, or ten thousand (10,000) hours of use, whichever occurs first. Supplier’s repair or replacement of any Product shall not extend the period of any warranty of any Product. This warranty applies to the exchange of part(s) found to be defective by an Authorized Powerex Service Representative only.

(d) Replacement Pumps – Parts Only (No Labor). For any replacement Air-End or Vacuum Pumps installed on a Powerex manufactured system or unit after any initial warranty period has expired or where another warranty does not apply for any reason, Powerex warrants that the Air-End or Vacuum Pumps shall be free of Defects for a period of thirty-six (36) months from the date of shipment by Powerex or ten thousand (10,000)hours of use, whichever comes first. For any replacement Air-End or Vacuum Pumps installed on a system that was not manufactured by Powerex after any initial warranty period has expired or where another warranty does not apply for any reason, Powerex warrants that the Air-End or Vacuum Pumps shall be free of Defects for the first twelve (12) months from the date of shipment by Powerex. Supplier’s repair or replacement of any Product shall not extend the period of any warranty of any Product. This warranty applies to the exchange of part(s) found to be defective by an Authorized Powerex Service Representative only.

(e) Replacement Motors – Parts Only (No Labor). For any replacement motor installed on a Powerex manufactured system or unit after any initial warranty period has expired or where another warranty does not apply for any reason, Powerex warrants that the replacement motor shall be free of Defects for the first twelve (12) months from the date of shipment by Powerex. For any replacement motor installed on a system or unit that was not manufactured by Powerex after any initial warranty period has expired or where another warranty does not apply for any reason, Powerex warrants that the replacement motor shall be free of Defects for the first ninety (90) days from the date of shipment by Powerex. Supplier’s repair or replacement of any Product shall not extend the period of any warranty of any Product. This warranty applies to the exchange of part(s) found to be defective by an Authorized Powerex Service Representative only.

(f) Replacement Parts – Parts Only (No Labor). For other replacement parts besides motors, Air-End or Vacuum Pumps installed on a Powerex manufactured system or unit after any initial warranty period has expired or where another warranty does not apply for any reason, Powerex warrants that such replacement parts will be free from Defects for the first twelve (12) months from the date of shipment by Powerex. For other replacement parts besides motors, Air-End or Vacuum Pumps installed on a system or unit that was not manufactured by Powerex after any initial warranty period has expired or where another warranty does not apply for any reason, Powerex warrants that such replacement parts will be free from Defects for the first twelve (12) months from the date of shipment by Powerex. For other replacement parts besides motors, Air-End or Vacuum Pumps installed on a system or unit that was not manufactured by Powerex after any initial warranty period has expired or where another warranty does not apply for any reason, Powerex makes no warranties. Supplier’s repair or replacement of any Product shall not extend the period of any warranty of any Product. This warranty applies to the exchange of part(s) found to be defective by an Authorized Powerex Service Representative only.

Instrument Air Package System

(g) Coverage The warranty provided herein applies to Powerex manufactured units or systems only.

(h) Exceptions. Notwithstanding anything to the contrary herein, Powerex shall have no warranty obligations with respect to Products:

- (i) that have not been installed in accordance with Powerex's written specifications and instructions;
- (ii) that have not been maintained in accordance with Powerex's written instructions;
- (iii) that have been materially modified without the prior written approval of Powerex; or
- (iv) that experience failures resulting from operation, either intentional or otherwise, in excess of rated capacities or in an otherwise improper manner.

(i) The warranty provided herein shall not apply to: (i) any defects arising from corrosion, abrasion, use of insoluble lubricants, or negligent attendance to or faulty operation of the Products; (ii) ordinary wear and tear of the Products; or (iii) defects arising from abnormal conditions of temperature, dirt or corrosive matter; (iv) any OEM component which is shipped by Powerex with the original manufacturer's warranty, which shall be the sole applicable warranty for such component.

Limitation of Liability. NOTWITHSTANDING ANYTHING TO THE CONTRARY HEREIN, TO THE EXTENT ALLOWABLE UNDER APPLICABLE LAW, UNDER NO CIRCUMSTANCES SHALL POWEREX BE LIABLE FOR ANY INCIDENTAL, CONSEQUENTIAL, PUNITIVE, SPECULATIVE OR INDIRECT LOSSES OR DAMAGES WHATSOEVER ARISING OUT OF OR IN ANY WAY RELATED TO ANY OF THE PRODUCTS OR GOODS SOLD OR AGREED TO BE SOLD BY POWEREX TO BUYER. TO THE EXTENT ALLOWABLE UNDER APPLICABLE LAW, POWEREX'S LIABILITY IN ALL EVENTS IS LIMITED TO, AND SHALL NOT EXCEED, THE PURCHASE PRICE PAID.

Warranty Disclaimer. Powerex has made a diligent effort to illustrate and describe the Products in its literature, including its Price Book, accurately; however, such illustrations and descriptions are for the sole purpose of identification, and do not express or imply a warranty that the Products are merchantable, or fit for a particular purpose, or that the Products will necessarily conform to the illustrations or descriptions.

Product Suitability. Many jurisdictions have codes and regulations governing sales, construction, installation, and/or use of Products for certain purposes, which may vary from those in neighboring areas. While Powerex attempts to assure that its Products comply with such codes, it cannot guarantee compliance, and cannot be responsible for how the product is installed or used. Before purchase and use of a Product, please review the Product applications, and national and local codes and regulations, and be sure that the Product, installation, and use will comply with them.

Claims. Any non-warranty claims pertaining to the Products must be filed with Powerex within 6 months of the invoice date, or they will not be honored. Prices, discounts, and terms are subject to change without notice or as stipulated in specific Product quotations. Powerex shall not be liable for any delay or failure arising out of acts of the public enemy, fire, flood, or any disaster, labor trouble, riot or disorder, delay in the supply of materials or any other cause, whether similar or dissimilar, beyond the control of Company. All shipments are carefully inspected and counted before leaving the factory. Please inspect carefully any receipt of Products noting any discrepancy or damage on the carrier's freight bill at the time of delivery. Discrepancies or damage which obviously occurred in transit are the carrier's responsibility and related claims should be made promptly directly to the carrier. Returned Products will not be accepted without prior written authorization by Powerex and deductions from invoices for shortage or damage claims will not be allowed. **UNLESS OTHERWISE AGREED TO IN WRITING, THE TERMS AND CONDITIONS CONTAINED IN THIS LIMITED WARRANTY WILL CONTROL IN ANY TRANSACTION WITH POWEREX.** Any different or conflicting terms as may appear on any order form now or later submitted by the buyer will not control. All orders are subject to acceptance by Powerex.