

Please read and save these instructions. Read carefully before attempting to assemble, install, operate or maintain the product described. Protect yourself and others by observing all safety information. Failure to comply with instructions could result in personal injury and/or property damage! Retain instructions for future reference.

DESCRIPTION

GENERAL

The Powerex Laboratory Air Compressor System is designed to provide clean, dry air for applications where the quality of the compressed air is critical. The standard unit is rated for a maximum of 145 PSIG. Each system includes multiple oil-less scroll air compressors, corrosion resistant air receiver, desiccant air dryers with purge control, a control panel and integrated dew point monitor. Systems are also equipped with dry type inlet filters, after coolers with condensate separators, check valves and ball valves for each pump. The air receiver tank has an electric timer type automatic drain and manual back up drain. The twin tower desiccant dryers are installed with ball valves and sized so that one dryer can meet full system flow needs. Final regulators are factory installed and set for a stable final pressure. Various options are available to make the system suit your needs, including a CO monitor or remote air intake capability.

The Powerex scroll air compressor has advanced scroll compressor technology through the development of a completely oil-less unit. The Powerex Scroll Compressor offers a dynamically balanced air end which insures vibration-free operation. The rotary design permits a continuous 100% duty cycle. No oil separation, oil filtration, or inlet valves are required on the Powerex scroll unit. The compressor is virtually maintenance free.

Systems are available with advanced PXMI touch screen controls to allow operation and monitoring of the unit. The systems utilize a programmable logic controller (PLC) to operate the number of pump motors required to meet demand. The control provides compressor high temperature, motor overload, and high dew point alarms.

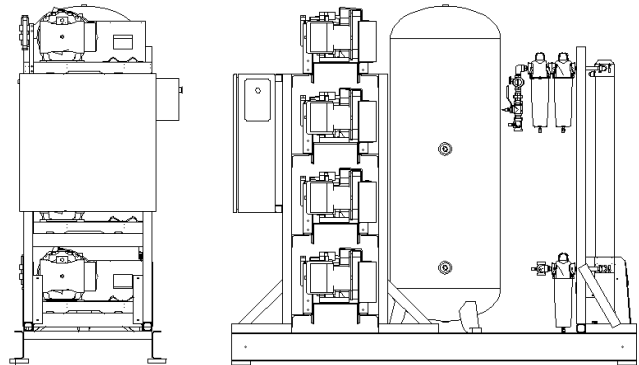

SPECIFICATIONS

Product	Laboratory Air Open Scroll Systems
Operating Voltages	208V, 230V, 460V
Control Panel	UL508A
Pressure Settings	Cut in: 115 psig Cut out: 145 psig
Tank	ASME Rated for 200 psi MAWP
Drive	3V Belt
Tank Sizes	80 Gallon to 200 Gallon
Performance	See Cut Sheet

Table of Contents			
Specifications	Pg 1	PXMI Controls	Pg 8-13
Safety Guidelines	Pg 2	Optional Webservice/ Gateway Card Set-up	Pg 14-19
Components	Pg 2-3	Maintenance	Pg 21
Installation	Pg 4-5	Warranty	Pg 24
Operation	Pg 5-6		

Laboratory Air Systems

SAFETY GUIDELINES

A SEPARATE SAFETY BOOKLET IS PROVIDED ALONG WITH THIS MANUAL. READ AND UNDERSTAND THE SAFETY BOOKLET. This manual contains information that is very important to know and understand. This information is provided for SAFETY and to PREVENT EQUIPMENT PROBLEMS. To help recognize this information, observe the following symbols. MAKE SURE EVERYONE OPERATING OR SERVICING THE COMPRESSOR READS AND UNDERSTANDS ALL THE INFORMATION PROVIDED.

⚠ DANGER *Danger indicates an imminently hazardous situation which, if not avoided, WILL result in death or injury.*

⚠ WARNING *Warning indicates a potentially hazardous situation which, if not avoided, COULD result in death or serious injury.*

⚠ CAUTION *Caution indicates a potentially hazardous situation which, if not avoided, MAY result in minor or moderate injury.*

NOTICE *Notice indicates important information, that if not followed, may cause damage to equipment.*

UNPACKING

Immediately upon receipt of the vacuum system, inspect for any damage which may have occurred during shipment. Repair or replace damaged items before use. The name-plate should be checked to verify the correct model and voltage.

⚠ WARNING *Do not operate unit if damaged during shipping, handling or use. Damage may result in bursting and cause injury or property damage.*

COMPONENTS

OILLESS SCROLL COMPRESSOR PUMPS

Powerex laboratory open scroll systems are designed to supply continuous oil-free air by using the most advanced scroll technology.

The Powerex scroll compressor offers a dynamically balanced air end which insures vibration-free operation. The rotary design permits a continuous 100% duty cycle. No oil separation, oil filtration, or inlet valves are required on the Powerex Scroll unit. Each compressor shall be belt driven oil-less rotary scroll single stage, air-cooled construction with absolutely no oil needed for operation. Direct drive compressors shall not be used. The rotary design shall not require any inlet or exhaust valves and shall be rated for 100% continuous duty. Systems consist of multiple compressor pumps that are automatically controlled and alternated to equalize usage and wear.

The Powerex oil-less rotary scroll air compressor is based on the theory of scroll compression. A scroll is a free-standing, intricate spiral bounded on one side by a solid, flat plane or base. A scroll set, the basic compression element of a scroll compressor, is made up of two identical spirals which form right and left hand parts. One of these scroll components is indexed or phased 180° with respect to the other so the scrolls can mesh. Crescent-shaped gas pockets are formed and bounded by the spirals and the base plate of both scrolls. As the moving scroll is orbited around the fixed scroll, the pockets formed by the meshed scrolls follow the spiral toward the center and diminish in size. The moving scroll is prevented from rotating during this process so that the 180° phase relationship of the scrolls is maintained. The compressor's inlet is at the outer boundary of the scrolls. The entering gas is trapped in two completely opposite gas pockets and compressed as the pockets move toward the center. The compressed gas is discharged through the outlet at the center of the fixed scroll so no valves are needed.

Each compressor shall have flexible connectors on intake and discharge, an electric drive motor, a discharge check valve, an air-cooled aftercooler and a high discharge temperature shut down switch. Each compressor module shall have an isolation valve and a moisture separator with automatic drain.

The scroll pump is driven by a three phase electric motor and a dual V-belt drive. The drive belts are engineered to provide trouble free service. Some dust is generated as the belts run to match the grooves on the motor pulley and pump. As long as no slippage is detected, the belts do not need to be tightened.

The system includes an after cooler for each pump and condensate separators with float type auto drains. Each pump module or stack of two pumps for 10 HP models is equipped with an isolation valve so that the pump or module may be removed for service and the valve closed leaving the system operable with partial capacity. (If the valve is used to isolate the system while a person is working or risk of injury exists, appropriate energy lock out tag out procedures must be employed.)

CONTROLS

The disconnects and protection devices in the Powerex control system are for the motor branch circuits, accessory supply circuits and for the control circuit only. The controls on the Powerex Laboratory Open Scroll System do not include a service disconnect and circuit protection for the supply circuit. Selection and installation of these items must be provided in compliance to local and national codes in accordance with each facility's need.

The PLC automatically alternates the lead designation and brings on lag pumps as needed, equalizing run time on the

pumps in the system. The touch screen HMI (Human Machine Interface) panel on the front allows operation and monitoring of the unit. The touch screen provides the user with displays showing the operating status and allows the user to access features of the control system. The control panel can also be configured with the optional PBMI feature which allows communication using the BacNet[®] protocol.

The control panel includes Hand-Off-Auto selector switches for each pump so that a pump can be held on (or off). This can be useful if maintenance or diagnostic procedures are being performed.

The controls have a transformer to provide control circuit voltage. The transformer is sized for the loads imposed by the Powerex factory controls and should not be utilized for any other purpose. PXMI control panels utilize a back up transformer with a reserve transformer in use alarm.

Local alarms are provided low pressure and general fault alarm. The general fault alarm includes high temperature, reserve transformer in use, motor overload and reserve pump in use (when specified). The wiring connection point for the alarms is on the terminal strip in the control panel box, with good conditions being contacts closed. (If a wire connection is lost, the result is an alarm.)

RECEIVER TANK & AIR DRYER (DESICCANT)

The ASME, National Board registered air receiver is provided in sizes from 80 to 200 gallons. Each receiver is rated at 200 psig working pressure. Receivers are provided with sight gauge, moisture drain (manual and electric), and internal lining to prevent corrosion.

The system receiver tank with bypass valves and duplex twin tower desiccant dryers are sized to provide adequate air storage and provide a pressure dew point of -40°F with one dryer operating. The system is not intended to operate with both dryers simultaneously. Doing so will result in back flow into one of the regulators and leakage of air from that device.

The receiver tank is equipped with a no-loss auto drain that is powered from the main control panel. The no-loss drain has a manual test feature. The automatic action of the drain will be confirmed by the lack of water accumulation.

CONDENSATE DRAIN VALVE (MANUAL)

A condensate drain valve must be installed on any tank. This valve removes liquid that collects during compressor operation. Drain liquid from tank daily.

The regenerative desiccant consists of two (dual) towers filled with desiccant. Each tower is switched on and off stream, alternating the air system stream and then being re-generated. Dry purge air pulls moisture from the desiccant and carries the moisture out of the system. The duplex twin tower desiccant dryers have isolation valves and each dryer has a condensate removal stage, a coalescing and an after filter. Differential pressure indicators show when the elements need to be replaced.

⚠ DANGER

Never drill holes in, or perform any welding on receiver tanks (unless qualified by ASME to do so) or use them beyond the rated pressure settings. Never mount other machinery or equipment on receivers.

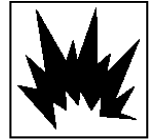

DEW POINT MONITOR

The Powerex dew point monitor provides indication of dew point temperature. It's microprocessor is controlled with alarm and self-calibration sensor.

Regen dryers paired with the Powerex dew point monitor may be operated in Econ Mode where the dew point monitor would signal the dryer to cease purge if system dew point is below the set point.

FRAMES OR TANK MOUNT STRUCTURE

Powerex designed the system to bear the weight and stress of the compressor pumps, controls, and receiver tank. When lifting the system, use the designated fork lift slots or rig straps to lift the main system skid. Do not attempt to lift the system using individual component lifting hooks and eyes. Piping may need to be supported to avoid damaging the supplied flex connectors for intake and exhaust.

OPERATION AT HIGH ALTITUDES:

Compressor pumps are sensitive to reduced atmospheric pressure encountered as altitude increases. Powerex will adjust the operating set points to compensate for altitude if the original order is designated for high altitude and the expected conditions provided to us.

Laboratory Air Systems

INSTALLATION

⚠WARNING	<i>Disconnect, tag and lockout power before attempting to install, service, relocate or perform any maintenance.</i>	
-----------------	--	---

⚠CAUTION	<i>Do not lift or move unit without appropriately rated equipment. Be sure the unit is securely attached to lifting device used. Do not lift unit by holding onto tubes or coolers. Do not use pumps to lift other attached equipment.</i>
-----------------	--

INSTALLATION SITE

1. The compressor system must be located in a clean, well lit and **well ventilated** area.
2. The area should be free of excessive dust, toxic or flammable gases and moisture.
3. Never install the vacuum system where the surrounding temperature is higher than 104°F or where humidity is high.
4. Clearance must allow for safe, effective inspection and maintenance.

MINIMUM CLEARANCES	
Above	36 inches
Other sides	36 inches

5. If necessary, use metal shims or leveling pads to level the system. Never use wood to shim the unit.

VENTILATION

1. If the oil-less compressor system is located in a totally enclosed room, an exhaust fan with access to outside air make up air must be installed. Room temperature must remain below 104°F.
2. Never restrict the cooling fan exhaust air. Maintain a minimum of 3 feet of clearance around the entire unit.
3. Never locate the compressor where hot exhaust air from other heat generating units may be pulled into the unit.

WIRING

⚠DANGER	<i>Lock out and tag out the electrical supply before servicing the equipment.</i>	
----------------	---	---

⚠DANGER	<i>Electrical shock hazard. Make sure the system is grounded in accordance with NEC and local requirements.</i>	
----------------	---	---

All electrical hook-ups must be performed by a qualified electrician. Installations must be in accordance with local and national electric codes. Make sure power supply conductors are sized adequately for full system demand.

PIPING

General Guidelines

Refer to the general product manual.

1. Make sure the piping is lined up without being strained or twisted when assembling the piping for the compressor.
2. Appropriate expansion loops or bends should be installed at the compressor to avoid stresses caused by changes in hot and cold conditions.
3. Piping supports should be anchored separately from the compressor to reduce noise and vibration.
4. Never use any piping smaller than the compressor outlet connection.
5. Use flexible hose to connect the outlet of the compressor to the piping so that the vibration of the compressor does not transfer to the piping.

Remote Intake Piping

Powerex Compressor Systems with pipe thread connectors on the intake filters are intended for installation with remote air intake. Piping for remote intake system must be installed at the final operating site.

Under some conditions, the intake piping may facilitate the condensation of humidity in the intake air stream into liquid water.

NOTICE	<i>The intake filters supplied by Powerex will not stop ingestion of liquid water by the pumps. Liquid water going into the pumps will damage the pumps and void the warranty.</i>
---------------	--

Always install drip legs with sufficient capacity to capture liquid water in the intake piping before the air filters. Drip legs must be sized with low enough air velocity to make sure they are effective at capturing liquid water in the intake air and must be maintained (drained) at frequent intervals to make sure they remain effective.

SAFETY VALVES, PRESSURE VESSELS AND PIPING

⚠ DANGER

1. Powerex systems are shipped with ASME safety valves sized so that the maximum system flow is less than the capacity of the valve or valves at the rated pressure. The rated pressure of the valve is equal to or higher than the maximum allowable working pressure of the vessel or upstream pressure bearing parts. **DO NOT MODIFY** or install any valves with different specifications unless appropriate evaluations are completed. Do not modify the structure of the pressure vessel or weld on the vessel.
2. Do not install any shut off valves between the safety valve and the vessel or between the compressor pump and the first system safety valve. Doing so can result in a dangerous condition and lead to death or injury.
3. Do not install shut off valves in the system that create trapped compressed air.
4. Manually operate the safety valve every six months or 2,500 operating hours to provide assurance that the mechanism is free to operate. Replace valve if it is leaking when it is closed or if it fails to vent when actuated.
5. Any piping or pressure bearing connection hose or tubing used in the system must be rated equal to or higher than the safety valve pressure rating. Inadequate pressure rating could result in bursting.

MODULAR PLACEMENT

1. Unpack each module and discard all wood shipping materials.
2. Some systems consist of multiple modules. The steel frames are intended to be bolted together using the supplied fasteners and connecting hoses provided (found in the parts pack box with the isolation pads). Modules may be spaced farther apart without any structural problems, but electrical connections may need to be modified—additional isolation pads and longer hoses may be needed.
3. Place modules at location designated. Provide sufficient clearance around unit for servicing (see minimum clearance section).
4. Install frame assembly fasteners to each frame joining the frames together.
5. Lift corners of each frame assembly and install isolation pads provided.

CONNECTING PIPING (if applicable)

1. Locate connection for piping at rear of unit for compressors module to receiver tank module.
2. Remove plastic caps or adhesive covering on ports and connectors.

3. Connect flex line to the ports making sure flex line is not pinched or kinked.
4. Follow steps 1 to 3 for flex line from dryer package to outlet of receiver tank.

NOTE: All piping is provided and sealed for this portion of installation.

5. If applicable, locate and attach intake inline air filter to outside source air or header. Flex line is provided when attaching intake of compressors to rigid piping.
6. Connect outlet of tank/dryer package located on dryer module to outlet source piping.

ELECTRICAL WIRING OF UNIT SHIPPED IN SEPARATE MODULES

⚠ CAUTION

Provide electrical power in accordance to NEC and local codes. Connection of wiring should be performed by a qualified electrician.

1. Connect wiring and flex conduit provided from each motor junction box to correct hole in bottom of control panel and starter.
2. Connect each temperature switch from the compressors to contacts located in control panel as marked for each temperature switch. Temperature switches shutdown the compressor when temperature reaches above a pre-set limit (425° for high pressure units; and if applicable 450° for standard pressure units). Connect dryer power cords, electric drain power cord, dew point and CO monitor power cords, and alarm wiring to the main control panel.

For questions concerning assembling and start-up, contact Powerex at 1-888-769-7979 for technical assistance.

OPERATION

BEFORE START UP

1. Make sure all safety warnings, labels and instructions have been read and understood before continuing.
2. Remove any shipping materials, brackets, etc.
3. Confirm that the electric power source and ground have been firmly connected.
4. Be sure all pressure connections are tight.
5. Check to be certain all safety relief valves, etc. are correctly installed.
6. Check that all fuses, circuit breakers, etc. are the proper size.
7. Make sure the inlet filter is properly installed.
8. Confirm that the drain valve is closed.
9. Once power is connected to the unit, visually check the rotation of the compressor pump. If the rotation is incorrect, have a qualified electrician correct the motor wiring.

Laboratory Air Systems

NOTICE

If all pumps are running in the wrong direction, change the incoming power leads to correct rotation.

START-UP AND OPERATION

1. Follow all procedures under “Before Start-Up” before attempting operation of the vacuum pump.
2. Make sure all selector switches are in the OFF position.
3. Switch on electric source.
4. Open tank connection valve or valves completely.
5. Using the selector switches on the control panel, turn on each pump—motor in the “Auto” mode until all are running.
6. Check for excessive vibration, unusual noises or leaks during operation. If problems are detected, shut down the system and make corrections or repair as needed before operating the system.
7. Pumps may be operated in “Hand” mode to override the function of the automatic controls. The pumps and the system will not be damaged during “hand” mode operation. The pumps are equipped with automatic vacuum limiting valves if needed to avoid damage.
8. In normal operation, leave all selector switches in the “Auto” position and allow the controls to cycle the pumps as needed based on compressor demand.

Laboratory Air Systems

LABORATORY AIR SCHEMATIC (THIS IS ONLY A REPRESENTATIVE SCHEMATIC DIAGRAM)

STANDARD FLOW SCHEMATIC

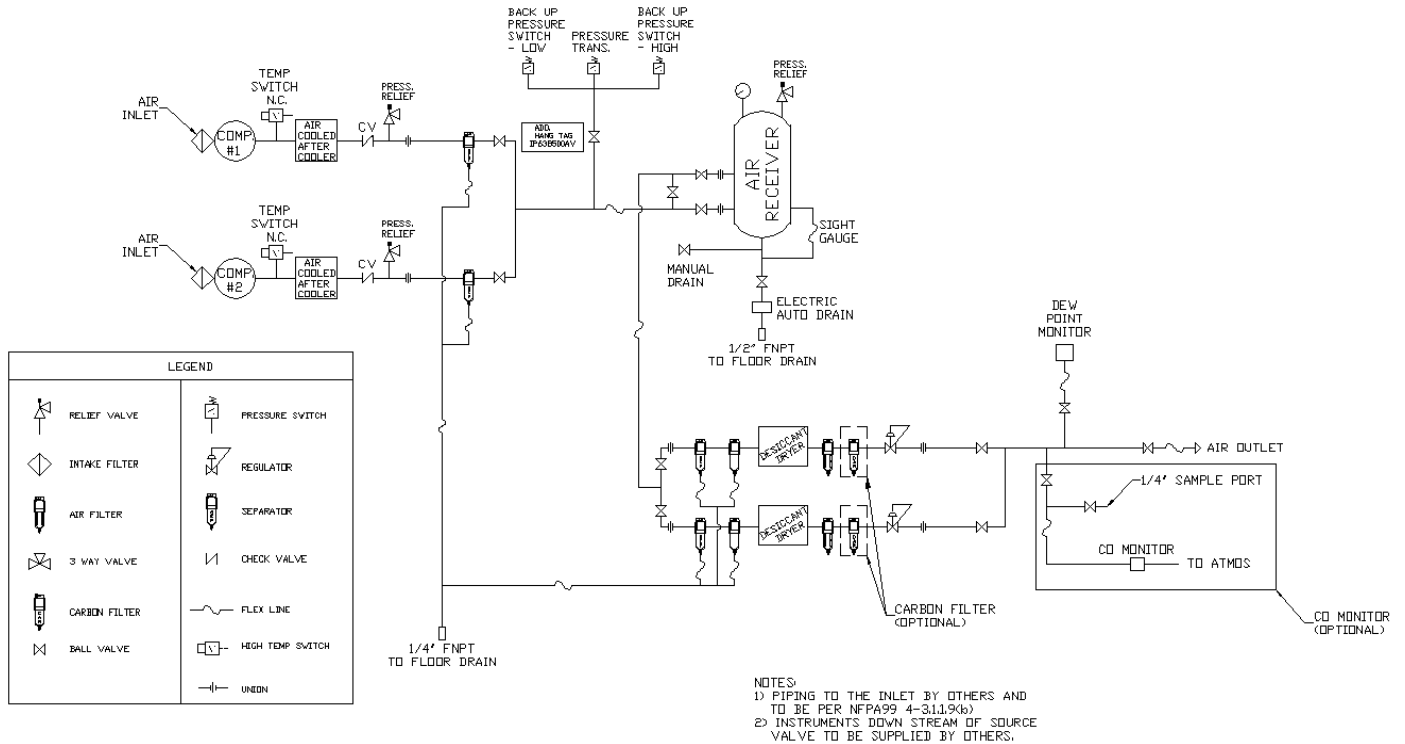

LABORATORY AIR SCHEMATIC WITH OPTIONAL REMOTE INLET (THIS IS ONLY A REPRESENTATIVE SCHEMATIC DIAGRAM)

FLOW SCHEMATIC W/ OPTIONAL REMOTE INLET

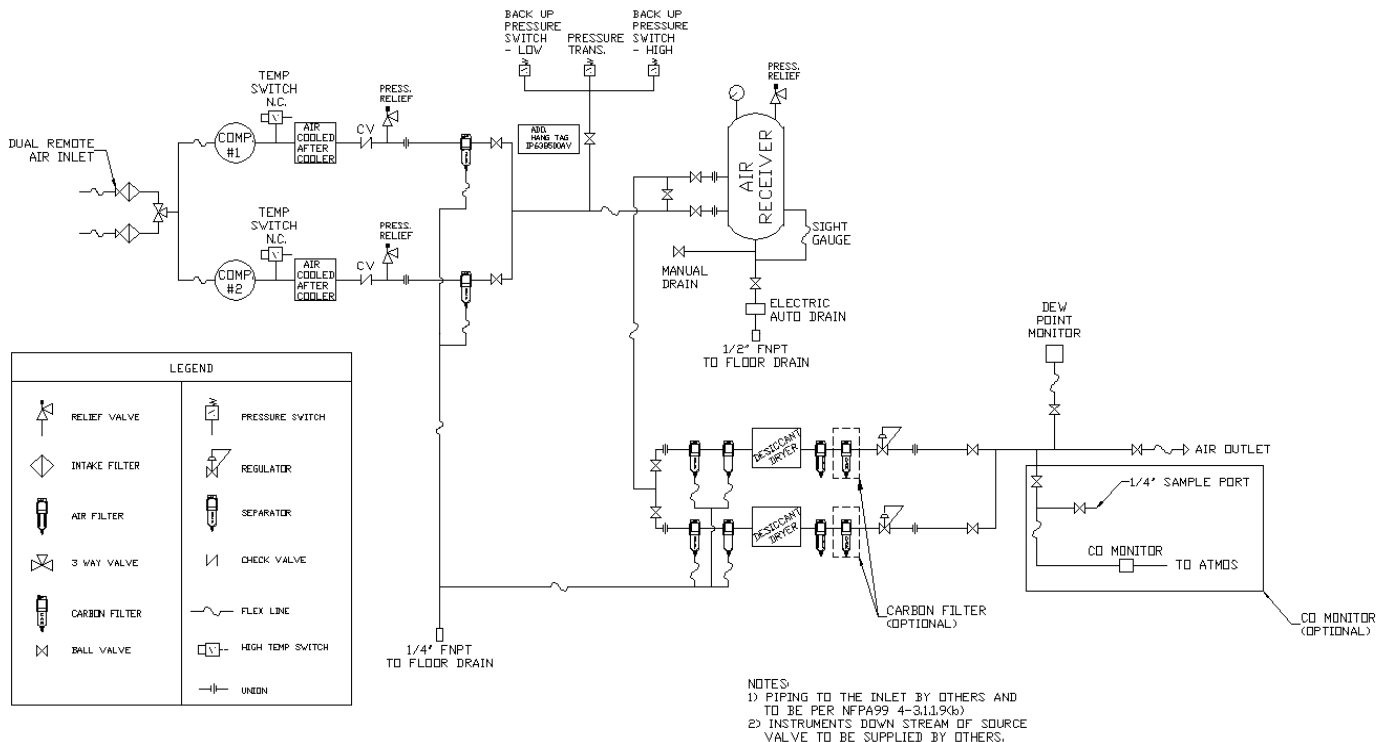

PG1—'MAIN'

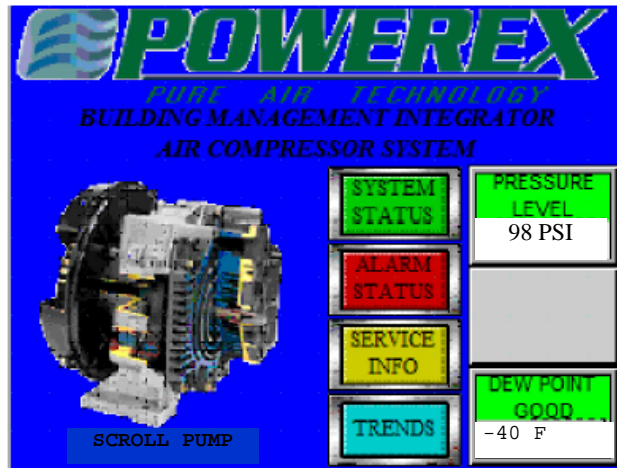

- Displays Pressure level and Dew Point level
- Pressure level will change from green to orange when high
- Dew Point level will change from green to orange when approaching alarm level; will change from orange to red when in alarm

PG2—'SYSTEM STATUS'

SYSTEM STATUS				01/11 15:16
PUMP1 ON	PUMP2 READY	PUMP3 OFF	PUMP4 OFF	PRES LEVEL 98 psi
FAULT STATE HOURS	FAULT STATE HOURS	HIGH TEMP ALARM HOURS	SERVICE REQUIRED HOURS	
250	250	248	247	
PUMP5 OFF	PUMP6 ON			DEW PNT GOOD -40 F
O/L TRIP ALARM HOURS	FAULT STATE HOURS			
249	250			

- Displays operating status, run hours, NFPA alarms, and Service alert of each pump on the system
- Displays Pressure level, and Dew Point level and status like on MAIN page

PG3—'ALARM STATUS'

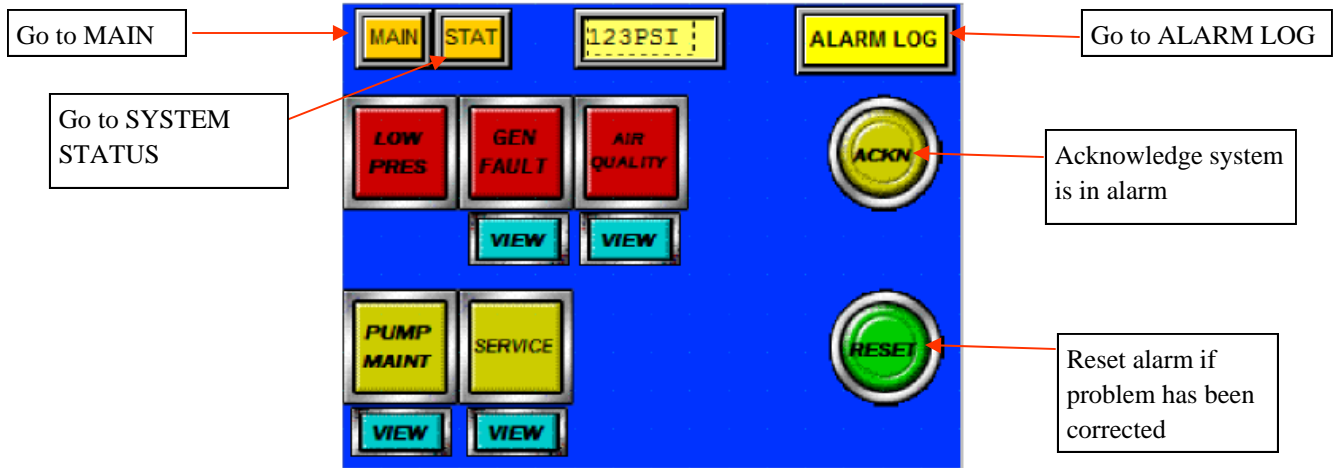

- Acknowledge and reset alarms
- Displays Pressure Level and Dew point level

PG4—'ALARM LOG'

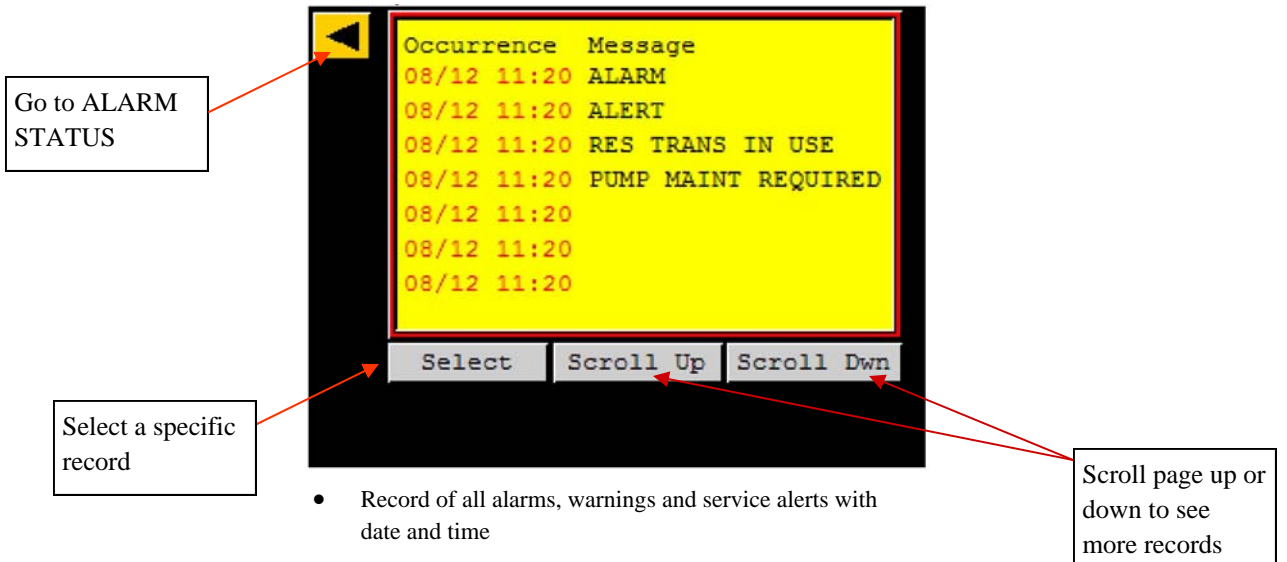

- Record of all alarms, warnings and service alerts with date and time

Laboratory Air Systems

PG5—'SERVICE'

Go to MAIN

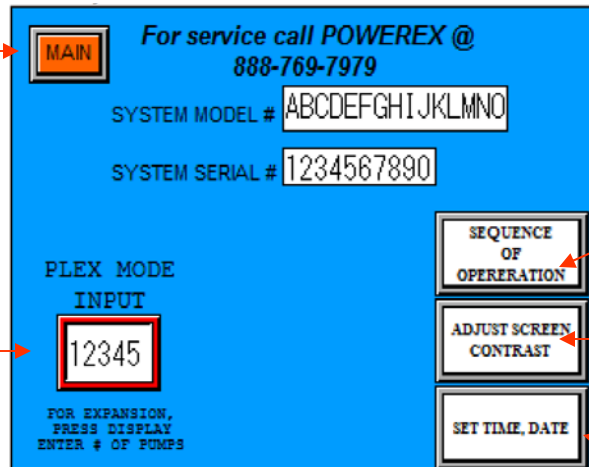

If system is expandable, re-adjust number of pumps

Go to SEQUENCE OF OPERATION

Make screen contrast lighter or darker

Set time and date

- Displays model number, serial number, service phone number
- If system is expandable, use Plex Mode Input to adjust PLC Program to additional pumps

TO SET TIME AND DATE:

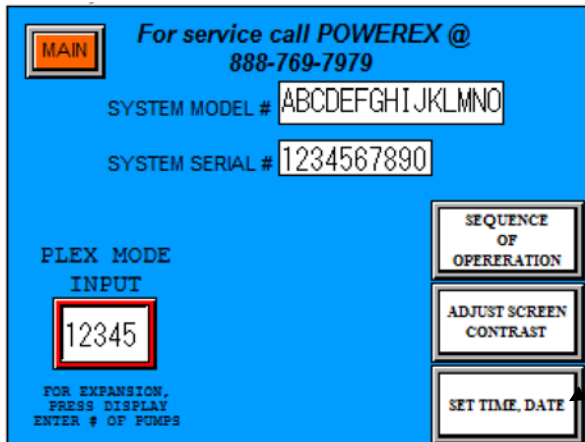

Press time, date button

THIS SCREEN WILL APPEAR

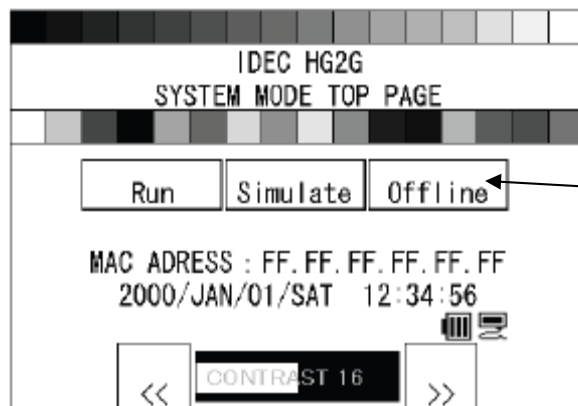

Press Offline

THIS SCREEN WILL APPEAR

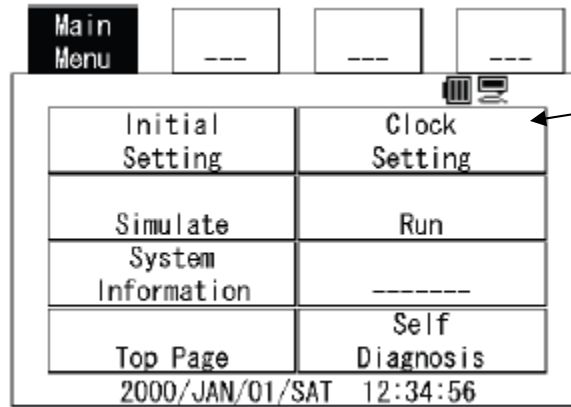

Press Clock Setting and enter time and date.

TO RETURN TO RUN MODE:

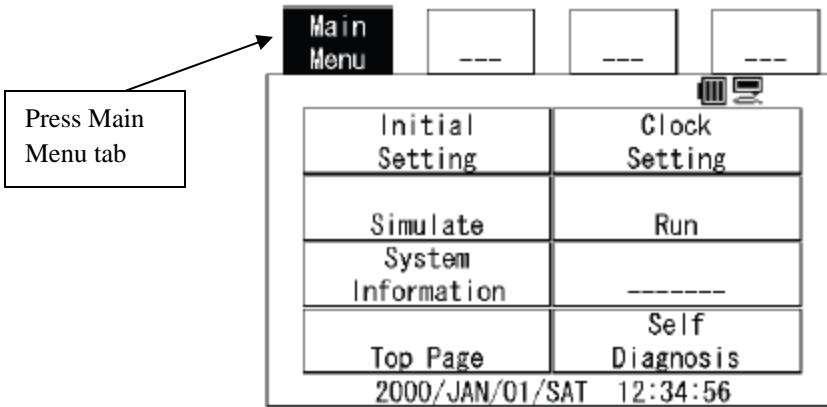

Press Main Menu tab

THIS SCREEN WILL APPEAR

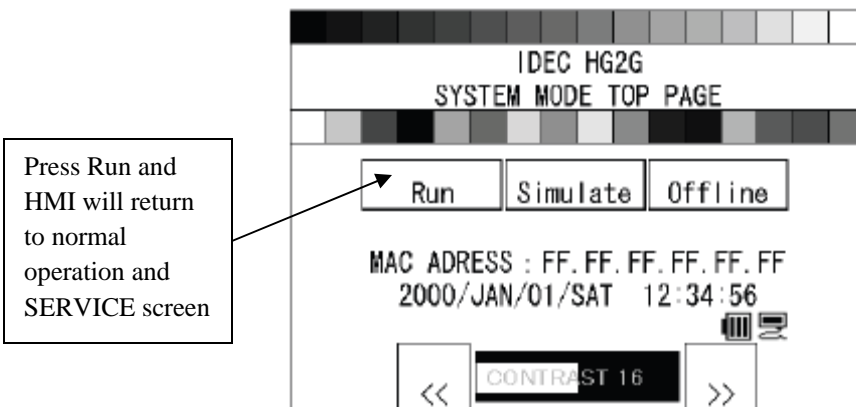

Press Run and HMI will return to normal operation and SERVICE screen

Laboratory Air Systems

PG6—'SEQUENCE OF OPERATION'

During normal operation the PBMI controller will signal the Lead compressor to run when pressure drops below lead cut-in set point and stop when the pressure reaches the lead cut-out set point. Lead alternation to the next pump, will occur with each lead run signal or every 10-minutes (which ever happens first). If demand cannot be satisfied by the lead pump, the lag pump(s) will start and stop based upon the lag cut-in and cut-out set-points and lead alternation will occur when the lowest cut-out set-point is satisfied, or 10-minutes (which ever happens first).

The RPUI (Reserve Pump In Use) alarm, H-Temp (High Discharge Air Temp) alarm, Motor Overload trip alarm, Reserve Transformer in use and Pump Service Required warnings will cause the touch screen to default to the Alarm Status Screen. Any and all alarms must be "Acknowledged" before navigating to other screens. The Pump Status Screen will indicate which pumps are running, any alarms, warnings and hours

BACK

NEXT

PG7—'DAILY LOAD FACTOR'

Go to MAIN

MAIN

DAILY LOAD FACTOR 123 %

SYSTEM RUN HOURS: 12345

Daily Load Factor is calculated from daily pump run hours over one 24-HOUR PERIOD. Total Hours is the accumulated run hours of all pumps in the system.

MAINTENANCE AND SERVICE ALERT SCREENS

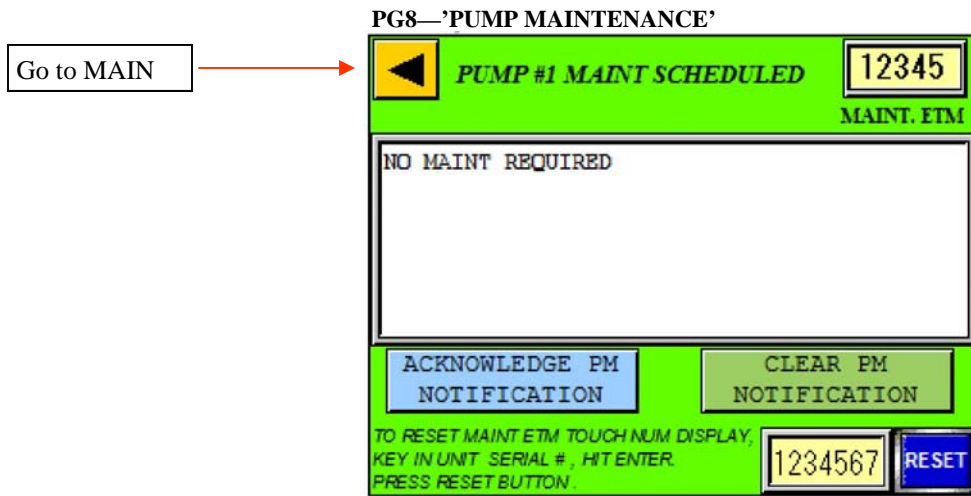

- At specific preset hour intervals, pump maintenance instructions will be displayed; this is specific to each pump

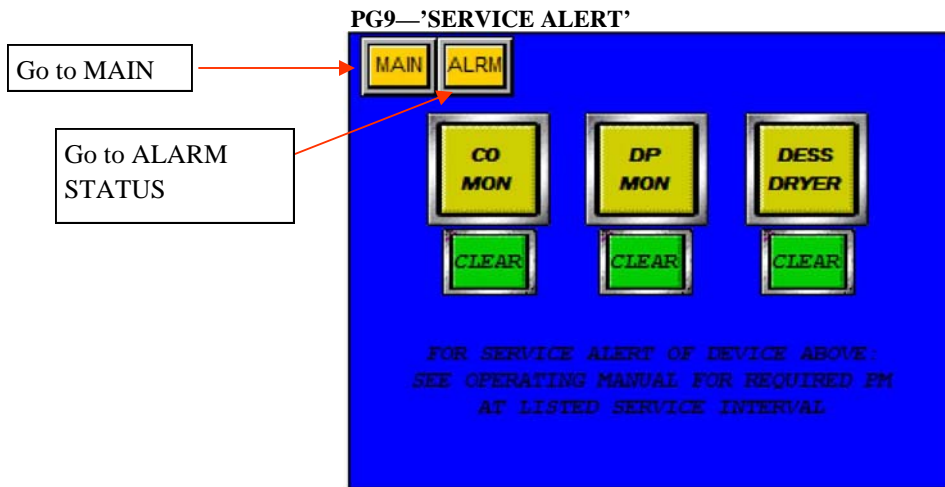

- At specific preset intervals, service alerts for the Dew Point Monitor and Dryer system will notify that maintenance is required

NOTE: PAGES 14-21 ARE INSTRUCTIONS FOR OPTIONAL PBMI WEBSERVER/BACNET® GATEWAY CARD. THESE INSTRUCTIONS ARE NOT APPLICABLE FOR SYSTEMS WITH HMI ONLY.

GATEWAY START-UP SCREENS

OVERVIEW

The 260MX-S027 Gateway device seamlessly connects Modbus RTU Slave devices to a BACnet/IP client. By following this guide, you will be able to configure the 260MX-S027 Gateway for basic operation. You will set the device's network settings and parameters to the proper configuration for initial operation and physically place the device in the network.

REQUIRED TOOLS AND DATA

You will need the following tools:

- ◆ The 260MX-S027 Gateway
- ◆ The provided CD-ROM
- ◆ A Working PC (Windows based)
- ◆ An Ethernet Crossover Cable
- ◆ A 12-24 VDC power source (T-strip)

NETWORK CONNECTIONS

The Gateway is shipped out with a Default IP Address of 172.16.3.159 and a Subnet of 255.255.248.0. In order to browse for the gateway's main page and begin configuring the gateway, you must change your PC to be on the same network as the gateway.

- 1) Change the IP Address of your PC to be 172.16.3.158
- 2) Change the Subnet of your PC to be 255.255.248.0
- 3) Open IPSetup.exe and browse for the gateway under select a unit.
- 4) Change the IP Address and Subnet to be on your network.
- 5) Click Set.
- 6) Change the PC's IP Address and Subnet back to its original settings.
- 7) Browse for the Unit using IPSetup.exe and launch the webpage.

ACCESSING THE MAIN PAGE

Before you can configure the gateway itself, you must configure the network settings to connect the gateway. The following steps will connect the gateway properly.

- 1) Connect the 12-24 VDC power source to the device.
- 2) Using the crossover cable, connect the device to the PC.
- 3) Insert the provided CD-ROM.
- 4) Run the IPSetup program from the CD-ROM.
- 5) Configure the IP Settings based on your subnet.
- 6) Click **Set**.
- 7) Click **Launch Webpage**. The Main page should appear.

NOTE

Browser configuration is compatible with Chrome, Internet Explorer, and Firefox.

Default IP address is 172.16.3.159

Welcome Pxpureair [logout](#) www.powerexinc.com

MODE: RUNNING
PE00047AV

Premium NFPA Controls

Main Page

Configuration Mode

Main Page

Device Configuration

CONFIGURATION

Device Description: Application Description
IP Address: 172.16.3.159
Subnet: 255.255.248.0
Default Gateway: 0.0.0.0
DNS Gateway: 0.0.0.0

Ethernet Link: 100 Mbps, Full Duplex
MAC Address: 00:03:F4:08:C4:1F
Revision: BETA

DIAGNOSTICS
-Select-

OTHER
-Select-

MODEL NUMBER
Not Configured

SERIAL NUMBER
Not Configured

SUPPORT
(888) 769-7979

Modbus Devices Configured: 0

Name	Value	Alarm
------	-------	-------

Powerex-Iwata Air Technology, Inc.
150 Production Dr. Harrison, OH 45030 USA
Ph: (888) 769-7979 Fax: (513) 367-3125

ERROR: MAIN PAGE DOES NOT LAUNCH

If the Main Page does not launch the IP Address is most likely incorrect. Correct the IP Address and try again. If you do not know the IP Address use the following procedure:

- 1) Open an MS-DOS Command Prompt.
- 2) Type ipconfig and press enter.
- 3) Note the IP address. (The previous example was 172.16.3.158)
- 4) To test the communication between the PC and the unit type ping (###.###.###.###) in the prompt and press Enter. The (###.###.###.###) is the IP address of the unit you used in step 5 of network configuration, which is 172.16.3.159 by default. If the device is connected to the network the ping will show a response. If you get no response check the crossover cable.

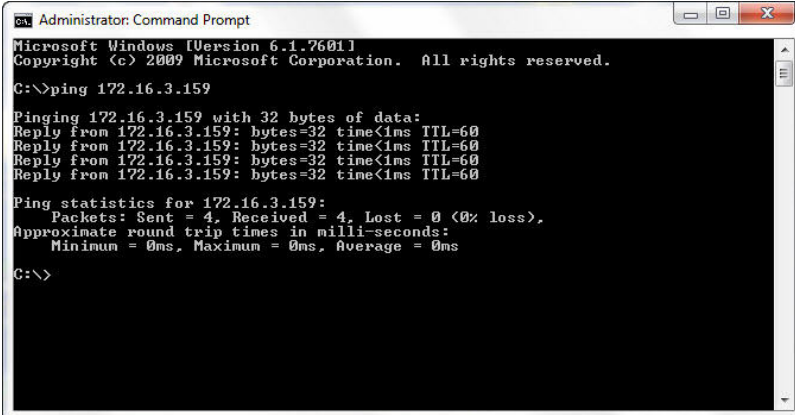

```
Administrator: Command Prompt
Microsoft Windows [Version 6.1.7601]
Copyright (c) 2009 Microsoft Corporation. All rights reserved.

C:\>ping 172.16.3.159

Pinging 172.16.3.159 with 32 bytes of data:
Reply from 172.16.3.159: bytes=32 time<1ms TTL=60
Reply from 172.16.3.159: bytes=32 time<1ms TTL=60
Reply from 172.16.3.159: bytes=32 time<1ms TTL=60
Reply from 172.16.3.159: bytes=32 time<1ms TTL=60

Ping statistics for 172.16.3.159:
    Packets: Sent = 4, Received = 4, Lost = 0 (0% loss),
    Approximate round trip times in milli-seconds:
        Minimum = 0ms, Maximum = 0ms, Average = 0ms

C:\>
```

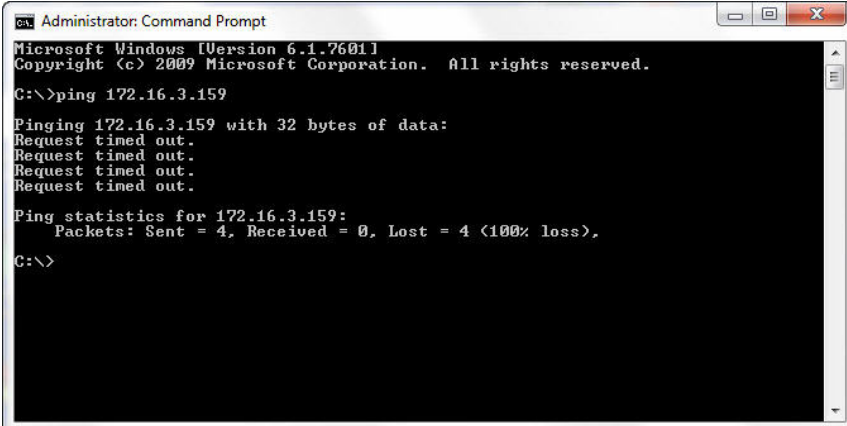

```
Administrator: Command Prompt
Microsoft Windows [Version 6.1.7601]
Copyright (c) 2009 Microsoft Corporation. All rights reserved.

C:\>ping 172.16.3.159

Pinging 172.16.3.159 with 32 bytes of data:
Request timed out.
Request timed out.
Request timed out.
Request timed out.

Ping statistics for 172.16.3.159:
    Packets: Sent = 4, Received = 0, Lost = 4 (100% loss),

C:\>
```

BACnet®/IP Server Settings

- 1) Click on the BACnet®/IP Server button. This will put the gateway into configuration mode so you can edit the BACnet® settings.
- 2) Enter the Device Instance that the 260MX-S027 will have on the BACnet®/IP Network. Note that this must be unique amongst all BACnet® devices on the network.
- 3) In the Name field enter a unique name for the device.
- 4) The Description and Location fields are optional. Filling in this information is recommended to identify the device on a network.
- 5) Beneath the Read Data Groups, verify the number of Analog Input (AI), Analog Output (AO), Binary Input (BI), and Binary Output (BO) objects that you will be exposing to the BACnet®/IP Client.
- 6) Click **Save Parameters**.

The screenshot shows the 'BACnet/IP Server Configuration' page for device PE000447AV. The interface includes a navigation menu on the left with options like 'Main Page', 'Port Configuration', 'BACnet/IP Server', 'Modbus RTU Master', and 'Display Data'. The main configuration area contains fields for 'Device Label' (BS01), 'UDP Port' (47808), 'Instance' (50), and 'Inactivity Timeout' (3000). There are also fields for 'Name', 'Description', and 'Location'. Below these are 'Save Parameters' and 'Edit Data Groups' buttons. A section titled 'Read Data Groups (PE000447AV to BACnet/IP)' contains a table with 2 data groups. A 'Data Group Data Limit' table shows limits for Analog Input (500) and Binary Input (500). At the bottom, there are buttons for 'Setup BACnet Names, Units, and COV' and 'Setup Static Device Binding and Foreign Device Registration', followed by another 'Save Parameters' button.

Data Group	Object Type	Starting Object	# of Objects
1	Analog Input (32 Bit Float)	1	0
2	Binary Input	1	0

Object Type	# of Objects
Analog Input	500
Binary Input	500

- 7) To save changes and force the gateway back to running mode, click on the Reboot Now button and after 5 seconds hit the Refresh button. You should see the gateway appear in Mode: Running.

Laboratory Air Systems - PBMI

ALARM CONFIGURATION

- 1) Click on the Other dropdown menu and select Alarm Configuration. Click on the Configuration Mode button to edit the alarm settings.
- 2) To enable an alarm, check the enable box.
- 3) If an alarm is enabled, then the Low Alarm and High Alarm must be set.
- 4) If the value of the point falls below the Low Alarm, the alarm is set and an email is generated if email is configured.
- 5) If the value of the point reaches the High Alarm, the alarm is set and an email is generated if email is configured.
- 6) Scroll to the bottom and Save Parameters.

Configuration Mode
Alarm Configuration
Help

Main Page
Alarm Delay upon Powerup: 0-3600 s

CONFIGURATION
of Alarms to Configure: 0-100

Load From Template

Port Configuration

BACnet/IP Server

Modbus RTU Master

Data Mapping

Display Data

DIAGNOSTICS
-Select-

OTHER
-Select-

	Enable	Data Point	Low Error	High Error	Alarm Name	Email
Alarm 1						
<input checked="" type="checkbox"/>	<input type="checkbox"/>	Lab Air Opt1 Dup Hex 001121 (t) 001121	<input type="text" value="0"/>	<input type="text" value="0"/>	System General Fault	<input type="text" value="None"/>
Alarm 2						
<input checked="" type="checkbox"/>	<input type="checkbox"/>	Lab Air Opt1 Dup Hex 001121 (t) 001121	<input type="text" value="0"/>	<input type="text" value="0"/>	Res Pump in Use	<input type="text" value="None"/>
Alarm 3						
<input checked="" type="checkbox"/>	<input type="checkbox"/>	Lab Air Opt1 Dup Hex 001124 (t) 001124	<input type="text" value="0"/>	<input type="text" value="0"/>	High Dewpoint Alarm	<input type="text" value="None"/>

- 7) To save changes and force the gateway back to running mode, click on the Reboot Now button and after 5 seconds hit the Refresh button. You should see the gateway appear in Mode: Running.

EMAIL CONFIGURATION

- 1) Click on the Other dropdown menu and select Email Configuration. Click on the Configuration Mode button to edit email settings.
- 2) Enter in the number of emails to configure and press Setup Email(s).
- 3) Enter in the SMTP Username. This email must have SMTP capability set up.
- 4) If the SMTP device requires authentication, enter in the Password for the SMTP Mail Username.
- 5) Enter in the SMTP Server that is being used.
- 6) Enter in the Email Address of the sender. This is going to be the same field as Step 3.
- 7) Enter in the Email Address of the recipient.
- 8) Select an Email Group for the user to be a part of. Multiple users may be part of a group and can receive the same alarm message.
- 9) Repeat steps 3-7 for multiple recipients.
- 10) Click Save Parameters.
- 11) Click Send Test Email to verify all of the email settings are correct.
- 12) To save changes and force the gateway back to running mode, click on the Reboot Now button and after 5 seconds hit the Refresh button. You should see the gateway appear in Mode: Running.

POWEREX Premium NFPA Controls

Welcome Pxpureair [logout](#) [www.powerexinc.com](#)

MODE: RUNNING PE000447AV

Configuration Mode: **Email Configuration** [Help](#)

Main Page

Number of Emails to Configure: 0-10 [Setup Email\(s\)](#)

CONFIGURATION

User	SMTP Mail Username	SMTP Mail Password	SMTP Server	From Email	To Email	Email Group
1	RTASupport	*****	172.16.3.159	RTASupport@SupportR	RTASupport@SupportR	Group A

DIAGNOSTICS [Save Parameters](#)

OTHER [Send Test Email\(s\)](#)

MODEL NUMBER
Not Configured

SERIAL NUMBER
Not Configured

SUPPORT
(888) 769-7979

Powerex-Iwata Air Technology, Inc.
150 Production Dr. Harrison, OH 45030 USA
Ph: (888) 769-7979 Fax: (513) 367-3125

Laboratory Air Systems - PBMI

SYSTEM STATUS

- 1) The main page shows the BACnet® Point, its current value, and whether an alarm is set.
- 2) The Value column will show the current value of the point upon a Refresh of this page.
- 3) If an alarm is enabled and is triggered, the point in an alarm state will be displayed in Red.

Welcome Pxpureair [logout](#)
www.powerexinc.com

Alarms Active
MODE: RUNNING

Premium NFPA Controls
PE000447AV

Configuration Mode

Main Page

Device Configuration Edit

CONFIGURATION

Load From Template

Port Configuration

BACnet/IP Server

Modbus RTU Master

Data Mapping

Display Data

DIAGNOSTICS

-Select-

OTHER

-Select-

MODEL NUMBER

Not Configured

SERIAL NUMBER

Not Configured

SUPPORT

(888) 769-7979

Main Page

Device Description: Lab Air Opt1 Dup Hex

IP Address: 172.16.3.159 Ethernet Link: 100 Mbps, Full Duplex

Subnet: 255.255.248.0 MAC Address: 00:03:F4:06:A4:21

Default Gateway: 0.0.0.0 Revision: 2.01

DNS Gateway: 0.0.0.0

Modbus Devices Configured: 1

Name	Value	Alarm
AI1	0.000000	
AI2	0.000000	High
AI3	0.000000	
AI4	0.000000	
AI5	0.000000	
AI6	0.000000	
AI7	0.000000	
AI8	0.000000	
AI9	0.000000	
AI10	0.000000	
AI11	0.000000	
AI12	0.000000	
AI13	0.000000	
AI14	0.000000	
AI15	0.000000	
AI16	0.000000	
AI17	0.000000	
AI18	0.000000	

LOCKING THE SYSTEM

- 1) To lock the system within the network, click on the Log Out button on the top of any page.
- 2) If the Username and/or Password is ever forgotten, click the Reset Password.
- 3) Click Confirm Reset.
- 3) Physically cycle power on the gateway within 15 minutes to gain access to the web pages. Set up the Security Settings again.

Security Log In

Lab Air Opt1 Dup Hex

Username:

Password:

Log In

Display Hint

Reset Password

MAC Address: 00:03:F4:06:A4:21

Admin Contact:

Powerex, Inc. (888) 769-7979

RESET THE USERNAME/PASSWORD

Please call Powerex at (888) 769-7979 with the MAC Address of the gateway. Once the correct Powerex Password is entered, you will be redirected to the Login Password and be prompted to enter in a new Username and Password.

Reset Login

Powerex Password:

MAC Address: 00-03-F4-03-6D-73

Product Name: PE000447AV

Product Revision: 1.15.03

Please write down your MAC Address and contact Powerex at (888) 769-7979.

Store Password

Laboratory Air Systems

INTEGRATED DIGITAL DEW POINT MONITOR

Specifications

Dew Point Range	-60°F to +54°F
Sensor Output	0 V-5 V Scaled as: below -60°F to over +54°F
Alarm Indication	Audible Alarm, HMI display
Alarm Output	Dry contacts. See drawing for contact ratings.
Alarm Set Point	HIGH ALARM: -20°F (-28.8°C)
Dryer Control Signals	10 AMP @ 115 VAC Rated Contact. (Normally Open) Contact Open for Purge rate fixed mode: -40°F to +54°F Contact Closed for Purge Saver mode: Below -45°F
Accuracy	±2°C dew point
Operating Pressure	10 psig—150 psig with a minimal flow rate
Operating Temperature	32°F to 131°F

SENSOR CALIBRATION AND ADJUSTMENT

The sensor is fully calibrated as shipped from the factory (see calibration sheet included in the main system manual). With the Daily Auto-Calibration feature (listed below) the sensor may not need replacement for up to 10 years. The manufacturer recommended replacement interval is 2 years from system start-up or if sensor should malfunction.

REPLACING THE FILTER

The sensor is protected with a stainless steel sintered filter. The filtering grade is 34 um.

The filter is recommended to be changed whenever it looks dirty or as a part of the periodical maintenance procedure. The recommended replacement interval depends heavily on the application and can vary from less than a year to several years. Dirty or corroded filter may cause increased response times. In case the sensor is used in a drying system with silica gel (or other drying agent) the dust from the dryer may collect on the sensor slowing the response but also generating a micro climate around the sensor altering the dew point at the sensor. This is easily corrected by changing or cleaning the filter.

Maintenance

CAUTION

Touching the sensor may damage it. Special attention shall be paid to avoid touching the sensor when removing and replacing filters.

DAILY AUTO-CALIBRATION

The Daily Auto-Calibration feature of the sensor is an automatic procedure which greatly reduces the possible drift in the dry end of the dew point measurement. It is performed at one hour intervals, and when the power is switched on. During auto-calibration the sensor is warmed for a short period (< 1 min) and the sensor capacitance values are evaluated at the elevated temperature. The possible dry end drift is then corrected to correspond to the calibrated values. During the auto-calibration the transmitter outputs the Td value prior to the procedure. Auto-calibration is carried out only if several criteria for the measurement environment are fulfilled. This ensures the reliability of the adjustments, and maintains the excellent long term stability that the patented technology offers. These criteria include e.g. a sufficiently stable enough moisture level in the measured atmosphere. If the conditions are not fulfilled, the auto-calibration function is postponed until the satisfied conditions are reached.

SENSOR PURGE

Sensor purge is also an automatic procedure that minimizes the drift at the wet end readings of the dew point measurement. Sensor purge is performed once a day or when the power is switched on. The sensor is heated for several minutes which will then evaporate all excess molecules out of the sensor polymer. This, together with the auto-calibration results in a very small drift of the sensor due to the very linear behavior of the polymer technology.

SENSOR WARMING IN HIGH HUMIDITIES

Additionally the sensor has a warming feature which prevents the sensor and filter from becoming wet in high humidities. High humidity can be present when the dew point temperature rises close to the gas temperature. Sensor warming is switched on automatically when the humidity level in the measured gas increases to a level where dew can start to form. The advantage of sensor warming is rapid response of dew point measurement. A wet sensor and filter would otherwise result in a dew point equal to ambient temperature (i.e. RH=100%). If the sensor becomes soaked in any way, it will fully recover and return back to normal operation after it dries out.

MAINTENANCE SCHEDULE

COMPRESSOR		Operating Hours						Remarks
Item	Action Needed	500	2500	5000	10,000	15,000	20,000	
Inlet air filter	Inspect, Replace	●		▲				Replace both at 5000 hours; alternate monthly
Blower fan	Clean			●	●	●	●	
Fan duct	Clean			●	●	●	●	
Compressor fins	Clean		●					Every 2500 hours or less
Bearings (145 psig scroll units)	Grease			▲	▲	▲	▲	EVERY 5000 hours
Tip seal (145 psig scroll units)	Replace			▲	▲	▲	▲	EVERY 5000 hours
Dust seal	Replace				▲		▲	
V-belt	Replace				▲		▲	See Note 3
Pressure switch/transducer	Confirm operation				●		●	
Magnetic starter	Inspect				●		●	Replace if contact point is deteriorated
Check valve	Replace						●	
Heat Insulation Pipe	Replace				●		●	

PIPING SYSTEM		Operating Hours						Remarks
Item	Action Needed	500	2500	5000	10,000	15,000	20,000	
Safety valve	Confirm operation		●					Every 2500 hours or less
Pressure gauge	Inspect		●					Every 2500 hours or less
Tank	Drain moisture	Daily						Verify proper drain operation
Air leaks	Inspect		●		●		●	
Filter element	Replace		▲	▲	▲	▲	▲	
Moisture drain traps	Inspect	●		●		●		View delta pressure indication

AIR DRYERS		Operating Hours						Remarks
Item	Action Needed	500	2500	5000	10,000	15,000	20,000	
Desiccant Dryer	Switch dryer Online/offline							Each month (see Dryer manual for Maintenance Instructions)

- Inspect
- ▲ Replace

NOTES:

1. Inspect and perform maintenance periodically according to the maintenance schedule.
2. The maintenance schedule relates to the normal operating conditions. If the circumstances and load condition are adverse, shorten the cycle time and perform maintenance accordingly.
3. Belts require no attention unless slippage is detected. (Chirping sound on start up or while running.) Re-tension as indicated when tip seals are replaced for the first time. Proper belt tension should be 0.25 inch deflection when 6 pounds of force is applied on the center of the belt span.
4. If the pumps reach 4 years and have not yet accumulated 5,000 hours, perform the greasing operation for the bearings, with the number of pumps reduced by 25%. (See details of pump grease operation.) Tip seals do not require early replacement, but must be done before or at 5,000 hours of run time.

Powerex Limited Warranty – Applicable to Non-OEM Customers in the U.S. & Canada Only

Warranty and Remedies. (a) General. Powerex warrants each Compressor System, Vacuum System, Vacuum Pump, Compressor Air-End, or Powerex branded Accessory (collectively “Products”, individually each a “Product”) to be free from defects in material and workmanship (“Defects”) at the date of shipment. This warranty shall apply only to Products that are purchased and used in the United States of America and in Canada. **EXCEPT AS SET FORTH BELOW, NO OTHER WARRANTY, WHETHER EXPRESS OR IMPLIED, INCLUDING ANY WARRANTY OF MERCHANTABILITY OR FITNESS FOR A PARTICULAR PURPOSE, SHALL EXIST IN CONNECTION WITH THE SALE OR USE OF SUCH PRODUCTS. TO THE EXTENT PERMITTED BY LAW, ANY AND ALL IMPLIED WARRANTIES ARE EXCLUDED.** All warranty claims must be made in writing and delivered to Powerex in accordance with the procedures set forth on its website (www.powerexinc.com), or such claim shall be barred. Upon timely receipt of a warranty claim, Powerex shall inspect the Product claimed to have a Defect, and Powerex shall repair, or, at its option, replace, free of charge, any Product which it determines to have had a Defect; provided, however, that if circumstances are such as to preclude the remedying of Defect by repair or replacement, Powerex shall, upon return of the Product, refund to buyer any part of the purchase price of such Products paid to Powerex. Freight for returning Products to Powerex for inspection shall be paid by buyer. The warranties and remedies herein are the sole and exclusive remedy for any breach of warranty or for any other claim based on any Defect, or non-performance of the Products, whether based upon contract, warranty or negligence.

(b) (i) Standard Period of Warranty – Parts and Labor - The purchase of any system includes our standard warranty. Powerex warrants and represents all Products shall be free from Defects for the first eighteen (18) months from the date of shipment by Powerex, or twelve (12) months from the documented date of startup, or five thousand (5,000) hours of use, whichever occurs first. During such warranty period, Powerex shall be fully liable for all Defects in the Products (the “Product Defects”), i.e., all costs of repair or replacement, which may include “in and out” charges, so long as the Products are located in the United States or Canada, and the Products are reasonably located and accessible by service personnel for removal. “In and out” charges include the costs of removing a Product from buyer’s equipment for repair or replacement.

(ii) Premium Period of Warranty – Parts and Labor – In order to be eligible for premium warranty coverage, a premium warranty for each system must be purchased when order is placed. Powerex warrants and represents all Products shall be free from Defects for the first thirty (30) months from the date of shipment by Powerex, or twenty-four (24) months from the documented date of startup, or seven thousand five hundred (7,500) hours of use, whichever occurs first. During such warranty period, Powerex shall be fully liable for all Defects in the Products (the “Product Defects”), i.e., all costs of repair or replacement, which may include “in and out” charges, so long as the Products are located in the United States or Canada, and the Products are reasonably located and accessible by service personnel for removal. “In and out” charges include the costs of removing a Product from buyer’s equipment for repair or replacement.

(c) Additional Period of Warranty – Parts Only (No Labor). In addition to the above, Powerex warrants each Powerex branded Compressor Air- End and Vacuum Pump shall be free of Defects for a period of forty-two (42) months from the date of shipment by Powerex, or thirty-six (36) months from the documented date of startup, or ten thousand (10,000) hours of use, whichever occurs first. Supplier’s repair or replacement of any Product shall not extend the period of any warranty of any Product. This warranty applies to the exchange of part(s) found to be defective by an Authorized Powerex Service Representative only.

(d) Replacement Pumps – Parts Only (No Labor). For any replacement Air-End or Vacuum Pumps installed on a Powerex manufactured system or unit after any initial warranty period has expired or where another warranty does not apply for any reason, Powerex warrants that the Air-End or Vacuum Pumps shall be free of Defects for a period of thirty-six (36) months from the date of shipment by Powerex or ten thousand (10,000)hours of use, whichever comes first. For any replacement Air-End or Vacuum Pumps installed on a system that was not manufactured by Powerex after any initial warranty period has expired or where another warranty does not apply for any reason, Powerex warrants that the Air-End or Vacuum Pumps shall be free of Defects for the first twelve (12) months from the date of shipment by Powerex. Supplier’s repair or replacement of any Product shall not extend the period of any warranty of any Product. This warranty applies to the exchange of part(s) found to be defective by an Authorized Powerex Service Representative only.

(e) Replacement Motors – Parts Only (No Labor). For any replacement motor installed on a Powerex manufactured system or unit after any initial warranty period has expired or where another warranty does not apply for any reason, Powerex warrants that the replacement motor shall be free of Defects for the first twelve (12) months from the date of shipment by Powerex. For any replacement motor installed on a system or unit that was not manufactured by Powerex after any initial warranty period has expired or where another warranty does not apply for any reason, Powerex warrants that the replacement motor shall be free of Defects for the first ninety (90) days from the date of shipment by Powerex. Supplier’s repair or replacement of any Product shall not extend the period of any warranty of any Product. This warranty applies to the exchange of part(s) found to be defective by an Authorized Powerex Service Representative only.

(f) Replacement Parts – Parts Only (No Labor). For other replacement parts besides motors, Air-End or Vacuum Pumps installed on a Powerex manufactured system or unit after any initial warranty period has expired or where another warranty does not apply for any reason, Powerex warrants that such replacement parts will be free from Defects for the first twelve (12) months from the date of shipment by Powerex. For other replacement parts besides motors, Air-End or Vacuum Pumps installed on a system or unit that was not manufactured by Powerex after any initial warranty period has expired or where another warranty does not apply for any reason,

Laboratory Air Systems

Powerex warrants that such replacement parts will be free from Defects for the first twelve (12) months from the date of shipment by Powerex. For other replacement parts besides motors, Air-End or Vacuum Pumps installed on a system or unit that was not manufactured by Powerex after any initial warranty period has expired or where another warranty does not apply for any reason, Powerex makes no warranties. Supplier's repair or replacement of any Product shall not extend the period of any warranty of any Product. This warranty applies to the exchange of part(s) found to be defective by an Authorized Powerex Service Representative only.

(g) Coverage The warranty provided herein applies to Powerex manufactured units or systems only.

(h) Exceptions. Notwithstanding anything to the contrary herein, Powerex shall have no warranty obligations with respect to Products:

- (i) that have not been installed in accordance with Powerex's written specifications and instructions;
- (ii) that have not been maintained in accordance with Powerex's written instructions;
- (iii) that have been materially modified without the prior written approval of Powerex; or
- (iv) that experience failures resulting from operation, either intentional or otherwise, in excess of rated capacities or in an otherwise improper manner.

(i) The warranty provided herein shall not apply to: (i) any defects arising from corrosion, abrasion, use of insoluble lubricants, or negligent attendance to or faulty operation of the Products; (ii) ordinary wear and tear of the Products; or (iii) defects arising from abnormal conditions of temperature, dirt or corrosive matter; (iv) any OEM component which is shipped by Powerex with the original manufacturer's warranty, which shall be the sole applicable warranty for such component.

Limitation of Liability. NOTWITHSTANDING ANYTHING TO THE CONTRARY HEREIN, TO THE EXTENT ALLOWABLE UNDER APPLICABLE LAW, UNDER NO CIRCUMSTANCES SHALL POWEREX BE LIABLE FOR ANY INCIDENTAL, CONSEQUENTIAL, PUNITIVE, SPECULATIVE OR INDIRECT LOSSES OR DAMAGES WHATSOEVER ARISING OUT OF OR IN ANY WAY RELATED TO ANY OF THE PRODUCTS OR GOODS SOLD OR AGREED TO BE SOLD BY POWEREX TO BUYER. TO THE EXTENT ALLOWABLE UNDER APPLICABLE LAW, POWEREX'S LIABILITY IN ALL EVENTS IS LIMITED TO, AND SHALL NOT EXCEED, THE PURCHASE PRICE PAID.

Warranty Disclaimer. Powerex has made a diligent effort to illustrate and describe the Products in its literature, including its Price Book, accurately; however, such illustrations and descriptions are for the sole purpose of identification, and do not express or imply a warranty that the Products are merchantable, or fit for a particular purpose, or that the Products will necessarily conform to the illustrations or descriptions.

Product Suitability. Many jurisdictions have codes and regulations governing sales, construction, installation, and/or use of Products for certain purposes, which may vary from those in neighboring areas. While Powerex attempts to assure that its Products comply with such codes, it cannot guarantee compliance, and cannot be responsible for how the product is installed or used. Before purchase and use of a Product, please review the Product applications, and national and local codes and regulations, and be sure that the Product, installation, and use will comply with them.

Claims. Any non-warranty claims pertaining to the Products must be filed with Powerex within 6 months of the invoice date, or they will not be honored. Prices, discounts, and terms are subject to change without notice or as stipulated in specific Product quotations. Powerex shall not be liable for any delay or failure arising out of acts of the public enemy, fire, flood, or any disaster, labor trouble, riot or disorder, delay in the supply of materials or any other cause, whether similar or dissimilar, beyond the control of Company. All shipments are carefully inspected and counted before leaving the factory. Please inspect carefully any receipt of Products noting any discrepancy or damage on the carrier's freight bill at the time of delivery. Discrepancies or damage which obviously occurred in transit are the carrier's responsibility and related claims should be made promptly directly to the carrier. Returned Products will not be accepted without prior written authorization by Powerex and deductions from invoices for shortage or damage claims will not be allowed.

UNLESS OTHERWISE AGREED TO IN WRITING, THE TERMS AND CONDITIONS CONTAINED IN THIS LIMITED WARRANTY WILL CONTROL IN ANY TRANSACTION WITH POWEREX. Any different or conflicting terms as may appear on any order form now or later submitted by the buyer will not control. All orders are subject to acceptance by Powerex.