

Scroll Enclosure Air Compressor 15-60 HP

Please read and save these instructions. Read carefully before attempting to assemble, install, operate or maintain the product described. Protect yourself and others by observing all safety information. Failure to comply with instructions could result in personal injury and/or property damage! Retain instructions for future reference.

Description

Powerex Scroll Enclosure Air Compressors are designed to supply continuous oil-free air by using the most advanced scroll technology. These turn-key packages are extremely quiet and offer electronic control that will reduce electrical power consumption.

The Powerex Oil-less Rotary Scroll Air Compressor has advanced scroll compressor technology through the development of a completely oil-less unit. The Powerex Scroll Compressor offers a dynamically balanced air end which insures vibration-free operation. The rotary design permits a continuous 100% duty cycle. No oil separation, oil filtration, or inlet valves are required on the Powerex Scroll unit. The compressor is virtually maintenance free.

The Powerex Oil-less Rotary Scroll Air Compressor is based on the theory of scroll compression. A scroll is a free standing, intricate spiral bounded on one side by a solid, flat plane or base. A scroll set, the basic compression element of a scroll compressor, is made up of two identical spirals which form right and left hand parts. One of these scroll components is indexed or phased 180° with respect to the other so the scrolls can mesh. Crescent-shaped gas pockets are formed and bounded by the spirals and the base plate of both scrolls. As the moving scroll is orbited around the fixed scroll, the pockets formed by the meshed scrolls follow the spiral toward the center and diminish in size. The moving scroll is prevented from rotating during this process so the 180° phase relationship of the scrolls is maintained. The compressor's inlet is at the outer boundary of the scrolls. The entering gas is trapped in two completely opposite gas pockets and compressed as the pockets move toward the center. The compressed gas is discharged through the outlet at the center of the fixed scroll so no valves are needed.

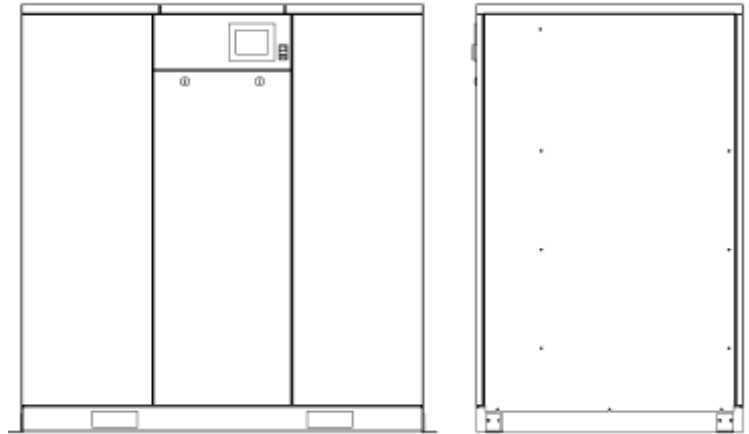

SPECIFICATIONS	
Product	SE Series Enclosed Scroll Air Compressor
Performance Specifications	See pg 2
Lubrication	Grease-filled Bearing
Operating Voltages	3Ø - 208-230/460/575 Volts, 60 Hz
Compression Cycle	Scroll
Motor Overload Protection	Motor Protector/Circuit Breaker
Pressure Settings	Cut in: 90psig Cut out: 116psig
Overpressure Protection	Safety Valve Factory Set and Sealed
Outlet Air Connections	See pg 2
Drive	3V Belt
Control Panel	UL508A Listed

Safety Guidelines

This manual contains information that is very important to know and understand. This information is provided for SAFETY and to PREVENT EQUIPMENT PROBLEMS. To help recognize this information, observe the following symbols.

⚠ DANGER Danger indicates an imminently hazardous situation which, if not avoided, WILL result in death or serious injury.

⚠ WARNING Warning indicates a potentially hazardous situation which, if not avoided, COULD result in death or serious injury.

⚠ CAUTION Caution indicates a potentially hazardous situation which, if not avoided, MAY result in minor or moderate injury.

NOTICE Notice indicates important information, that if not followed, may cause damage to equipment.

NOTE: Note indicates information that requires special attention.

Since the air compressor makes up a high pressure system, the following safety precautions must be observed at all times.

1. Read all manuals included with this product carefully. Be thoroughly familiar with the controls and the proper use of the equipment.
2. Follow all local electrical and safety codes as well as in the United States, the National Electrical Codes (NEC) and Occupational Safety and Health Act (OSHA).

Specification Chart

Model	HP	Max Pressure PSIG	SCFM @ 100 PSIG	Voltage	Noise Level dB(A)	Discharge Connection	Discharge Air Approach Temp
SED15B	7.5 (2)	116	46.2	208/230/460	63	1" NPT	15°F
SED20B	10 (2)	116	62.4	208/230/460	64	1" NPT	16°F
SET225	7.5 (3)	116	69.3	208/230/460	65	1" NPT	19°F
SET30B	10 (3)	116	93.6	208/230/460	66	1" NPT	20°F
SEQ40B	10 (4)	116	125	208/230/460	66	1 ¼" NPT	16°F
SEH45B	7.5 (6)	116	139	208/230/460	66	1 ¼" NPT	16°F
SEP50B	10 (5)	116	156	208/230/460	67	1 ¼" NPT	19°F
SEH60B	10 (6)	116	187	208/230/460	69	1 ¼" NPT	20°F

⚠ DANGER

Breathable Air Warning

This unit is NOT equipped and should NOT be used "as is" to supply breathing quality air. For any application of air for human consumption, you must fit the air compressor with suitable in-line safety and alarm equipment. This additional equipment is necessary to properly filter and purify the air to meet minimal specifications for Grade D breathing as described in Compressed Gas Association Commodity Specification for Air, OSHA, ANSI and/or Canadian Standards Associations (CSA).

When the SE series compressor unit is used as part of an appropriately configured Medical Air System, meeting all requirements of NFPA 99, it is safe to utilize as a breathing air source.

DISCLAIMER OF WARRANTIES

IN THE EVENT THE COMPRESSOR IS USED FOR THE PURPOSE OF BREATHING AIR APPLICATION AND PROPER IN-LINE SAFETY AND ALARM EQUIPMENT IS NOT SIMULTANEOUSLY USED, EXISTING WARRANTIES ARE VOID, AND POWEREX DISCLAIMS ANY LIABILITY WHATSOEVER FOR ANY LOSS, PERSONAL INJURY OR DAMAGE.

- Only persons well acquainted with these rules of safe operation should be allowed to use the compressor.
- Keep visitors away and NEVER allow children in the work area.
- Wear safety glasses and use hearing protection when operating the unit.
- Do not stand on or use the unit as a handhold.
- Before each use, inspect compressed air system and electrical components for signs of damage, deterioration, weakness or leakage. Repair or replace defective items before using.

- Check all fasteners at frequent intervals for proper tightness.

⚠ WARNING Motors, electrical equipment and controls can cause electrical arcs that will ignite a flammable gas or vapor. Never operate or repair in or near a flammable gas or vapor. Never store flammable liquids or gases in the vicinity of the unit.

⚠ WARNING Never operate compressor pump without a protective guard. This unit can start automatically without warning. Personal injury or property damage could occur from contact with moving parts.

- Do not wear loose clothing or jewelry that will get caught in the moving parts of the unit.

⚠ CAUTION Surface may be hot even if unit is stopped.

- Keep fingers away from a running unit; fast moving and hot parts will cause injury and/or burns.
- If the equipment should start to vibrate abnormally, STOP the unit and check immediately for the cause. Vibration is generally a warning of trouble.
- To reduce fire hazard, keep unit exterior free of oil, solvent, or excessive grease.

⚠ WARNING An ASME code safety relief valve with a setting no higher than the tank maximum allowable working pressure MUST be installed in the air lines or in the tank of any compressor. The ASME safety valve must have sufficient flow and pressure ratings to protect the pressurized components from bursting.

- Never attempt to adjust ASME safety valve on compressed air units. Keep safety valve free from paint and other accumulations.

⚠ DANGER Never attempt to repair or modify a tank! Welding, drilling or any other modification will weaken the tank resulting in damage from rupture or explosion. Always replace worn, cracked or damaged tanks.

NOTICE Drain liquid from tank daily.

14. Tanks rust from moisture build-up, which weakens the tank. Make sure to drain tank regularly and inspect periodically for unsafe conditions such as rust formation and corrosion.
15. Fast moving air will stir up dust and debris which may be harmful. Release air slowly when draining moisture or depressurizing a compressor system.

Installation

WARNING Disconnect, tag and lock out power source then release all pressure from the system before attempting to install, service, relocate or perform any maintenance.

CAUTION Do not lift or move unit without appropriately rated equipment. Be sure the unit is securely attached to lifting device used. Do not lift unit by holding on to tubes or coolers. Do not use unit to lift other attached equipment.

CAUTION Never use the wood shipping skids for mounting the unit.

CAUTION Do not locate the air inlet near steam, paint spray, sandblast areas or any other source of contamination.

NOTE: If compressor system is installed in a hot, moist environment, supply compressor pump with clean, dry outside air. Pipe supply air in from external sources.

WARNING Failure to properly install a tank can lead to cracks at the welded joints and possible bursting or leakage.

Unpacking

After unpacking the unit, inspect carefully for any damage that may have occurred during transit. Make sure to tighten fittings, bolts, etc., before putting unit into service.

WARNING Do not operate unit if damaged during shipping, handling or use. Damage may result in unsafe conditions and cause injury or property damage.

The compressor nameplate should be checked to see if the unit is the correct model and voltage as ordered.

Precautions During Transportation & Movement – Transportation by Forklift

Use openings for forklift under both sides of the unit.

NOTICE Avoid damaging the panel with tips of forklift.

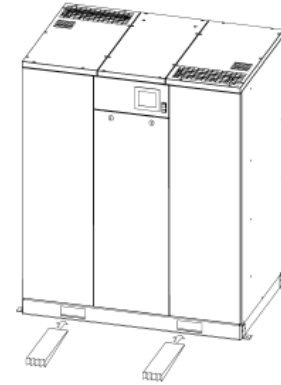

Figure 1

Transportation by Crane

Use openings at bottom of the unit to lift up by cable, lifting straps etc. Make sure all lifting devices are rated for the maximum load.

NOTICE Be sure to use pads in order to protect the panels.

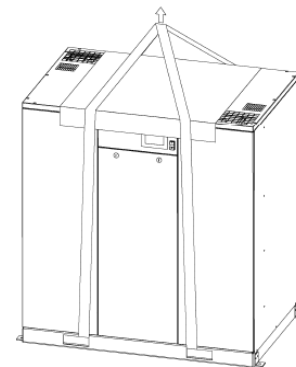

Figure 2

Installation Site

1. The scroll compressor must be located in a clean, well lit and well ventilated area. A contaminated area can clog the intake filter and / or intake metal mesh.
2. The area should be free of excessive dust, toxic or flammable gases, moisture and direct sunlight.
3. Never install the compressor where the ambient temperature is higher than 104°F or where humidity is high. High humidity will cause electrical short circuit and rusting of components.
4. Clearance must allow for safe, effective inspection and maintenance.

NOTICE A minimum of 24 inches of clearance for sides, 40 inch clearance from the top is required. Consult OSHA and NEC for requirements on clearance for electrical access. 36 inches or more may be required.

5. If necessary, use metal shims or leveling pads to level the compressor. Never use wood to shim the compressor.

Ventilation

1. If the scroll compressor is located in a totally enclosed room, an exhaust fan with access to outside air make up air must be installed.
2. Never restrict the cooling fan exhaust air or the intake cooling air.
3. Vent the exhaust air outside to prevent the compressor from operating at high temperatures and shutting down.
4. Never locate the compressor where hot exhaust air from other heat generating units may be pulled into the unit.

Suggested Ventilation System

The temperature rise in the room must be kept to a maximum of 10 F. The BTU capacity of the vent system should be sized for the full operating HP rating of the compressor. Suggested fan capacity at 0 static pressure is shown below. If static pressure is higher, the fan capacity should be increased.

An exhaust duct may be installed to capture the warm air exiting the compressor enclosure. The opening of the exhaust duct should be about 6 inches larger on each side than the vent openings on the compressor top panel. The duct should not obstruct removal of the top panel for service. Leave between 8 and 12 inches of clearance. The CFM capacity of the exhaust fan should be increased to compensate for duct flow losses. Increase CFM if incoming air is above 85°F.

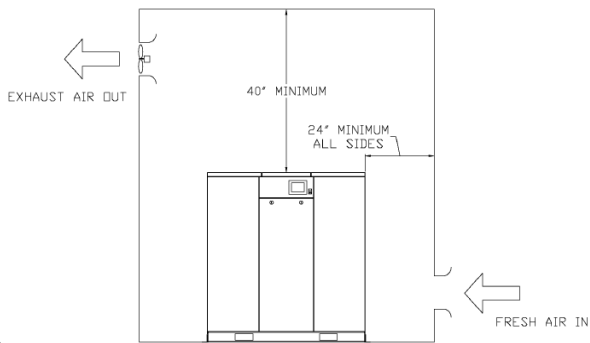

Figure 3

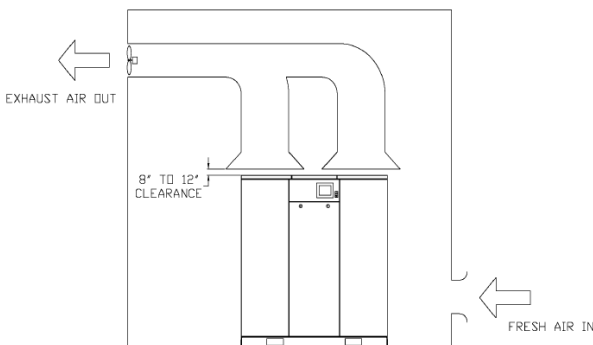

Figure 4

Total HP	Exhaust CFM Required	
	Figure A	Figure B
15	5000	1700
20	6700	2200
22.5	7600	2500
30	10100	3400
40	13500	4500
45	15100	5000
50	16800	5600
60	20200	6700

Table 1

Wiring

⚠ WARNING All wiring and electrical connections must be performed by a qualified electrician. Installations must be in accordance with local and national codes.

⚠ CAUTION Overheating, short circuiting and fire damage will result from inadequate wiring.

The Powerex Scroll Enclosure Air Compressor is completely factory wired and requires only a 3 phase supply circuit. A set of terminals is provided for connection of the supply conductors and ground conductor.

A 2-inch opening is provided for conduit or cord connection.

Wiring must be installed in accordance with National Electric Code and local codes and standards that have been set up covering electrical apparatus and wiring. Consult the codes and standards and observe local ordinances. Be certain that adequate wire sizes are used, and that:

1. Service is of adequate ampere rating.
2. The supply line has the same electrical characteristics (voltage cycles and phase) as the motor.
3. Ensure the line wire is the proper size and that no other equipment is operated from the same line.

Grounding

This product must be grounded. Grounding reduces the risk of

⚠ DANGER Improperly grounded electrical components are shock hazards. Make sure all the components are properly grounded to prevent death or serious injury.

electrical shock by providing an escape wire for the electrical current if short circuit occurs.

All electrical hook-ups must be performed by a qualified electrician. Installations must be in accordance with local and national electrical codes.

1. A service disconnect and fuses or a circuit breaker must be installed to supply electric power to this compressor. Make

sure the circuit is sized to handle the full operating load as shown in the table on the unit wiring diagram or rating decal.

For some models supplied by Powerex as part of an NFPA99 Medical Air System, a service disconnect is incorporated into the front instrument panel. This disconnect does not provide circuit overload or short circuit protection.

2. On SED – SET models, access the electric panel and wiring area by removing the right side panel.

On SEQ, SEP, and SEH models the electric panel and wiring area is behind the front center panel. Models that are part of Medical Air Systems have an additional access cover on the roof panel over the instrument area.

3. Using appropriate strain relief and cable management techniques, connect the power cable to the power junction block and the ground wire to the ground bar. Consult your NEC and local codes for wire size.

General Fault Dry Contact Connections

1. Turn the compressor off and lockout the power to the compressor per OSHA standards.
2. Remove the front door panel for SEQ-SEH units, and the right panel for SED-SET units, from the scroll cabinet to access the operating panel.
3. Output wires should be connected between terminals 10 and 11. The dry contacts are normally closed; when there is a fault or loss of power to the system, the contacts open. The contact rating is as follows: 240VAC/2A or 30VDC/2A, maximum.
4. For larger load devices such as a horn or emergency light, a relay should be used.
5. The signal wires should be between 16 and 18 AWG.
6. Replace the door panel to the scroll compressor cabinet.

⚠ WARNING *Never use plastic (PVC) pipe for compressed air. Serious injury or death could result.*

7. Return the power to the compressor system.

Piping

Any tube, pipe or hose connected to the unit must be able to withstand the temperature generated and retain the pressure. All pressurized components of the air system must have a pressure

⚠ WARNING *Never install a shut-off valve between a compressor pump and the tank without an appropriate safety valve. Personal injury and/or equipment damage may occur. Never use reducers in discharge piping.*

rating higher than or equal to the ASME safety valve setting. Incorrect selection and installation of any tube, pipe or hose could result in bursting and injury.

The Powerex Scroll Enclosure Air Compressor has an ASME safety relief valve at the outlet pipe nipple connection point. Bury underground lines below the frost line and avoid pockets where

condensation can gather and freeze.

Apply air pressure to the piping installation and make sure all joints are free from leaks BEFORE underground lines are covered. Before putting the unit into service, find and repair all leaks in the piping, fittings and connections.

Select the size of the air receiver so that the combined volume of

Differential*	Duplex	Triplex	Quad	Penta	Hex
Min.	120	120	200	200	240
Standard	120	120	120	200	240
Max.	120	120	120	120	200

*Pressure setting selected on control panel

Table 2

the air receiver and facility piping results in a long enough cycle time to keep any individual motor from starting more than once every 3.43 minutes. Selecting the widest possible spread between high and low system set point pressure along with the largest differential for each pump interval will reduce the starting frequency.

The table below shows the recommended tank size in gallons per model. Some conditions of air usage may require additional volume.

1. Make sure the piping is lined up without being strained or twisted when assembling the piping to the scroll enclosure.
2. Appropriate expansion loops or bends should be installed at the compressor to avoid stresses caused by changes in hot and cold conditions.
3. Piping supports should be anchored separately from the compressor to reduce noise and vibration.
4. Never use any piping smaller than the compressor outlet connection.
5. Use flexible hose to connect the outlet of the compressor to the piping so that the vibration of the compressor does not transfer to the piping.

Safety Valves

Safety Valves must be installed on every receiver. The flow capacity of a safety valve should be equal to or greater than the capacity of the compressor.

1. The pressure setting of the safety valve must not be greater than the maximum working pressure of the air receiver.
2. Safety valves should be placed ahead of any possible blockage point in the system, i.e. shutoff valve.
3. Avoid connecting the safety valve with any tubing or piping.
4. Manually operate the safety valve every six months to avoid sticking or freezing.

Check Valves

Do not install a check valve between the compressor and the air receiver or facility piping. If a check valve is installed, the compressor pressure sensor will see rapid pressure drops and cause short cycling of the motors and other control problems.

Isolation Valves

An isolation valve should be installed between the compressor and the air receiver to facilitate maintenance. Make sure the valve is open when operating the compressor. A second isolation valve should be installed between the air receiver and the facility piping.

Intake Air Connections

Powerex 7.5 and 10 HP Scroll enclosed models normally have an intake filter assembled to each compressor pump. These filters are located internal to the sound mitigating compartment to provide maximum protection for the pump and reduce noise near the enclosed compressor system.

For models supplied with remote intake capability, such as those used in Medical Air systems and other special applications the pump intakes are routed together and an externally mounted air filter assembly is installed. This filter is provided with an isolation valve so that if the unit is removed from service the branch connection to the main intake header can be closed. **NOTICE** operating the compressor unit with the isolation valve closed will result in catastrophic damage to the pumps. Powerex provides the valves with the handle removed and stored in the system control enclosure. We suggest utilization of this handle be controlled to prevent accidental operation with the valve closed. Multi stack models such as the SEQ SEP and SE H series will have a filter and valve for each stack.

Unit Vibration Isolation

Each pump motor assembly in the Powerex unit has isolation mounting between its support rails and the system frame. Additional isolation is not required, but is allowable if desired. Powerex can supply cork rubber composite mounting pads to use under the corners of the base platforms if desired. Contact customer service if necessary. Some systems may be provided with the isolation pads.

Condensation and Condensation Separators

The Powerex 7.5 and 10 HP Scroll Enclosed compressor units include after coolers that will generate condensation in the compressed air outlet lines. Some models are shipped with condensate traps for field installation external to the enclosure and systems will typically have condensate traps installed by Powerex. Locate the condensate traps where they can be conveniently accessed for maintenance. When an isolation valve is used for a compressor unit, it may be beneficial to locate the trap on the compressor side so the trap can be isolated with the unit for maintenance and service.

NOTICE Do not install check valves between the compressor unit and the system air receiver. The compressor pressure sensor must be in full connection with the air receiver for the controls to operate properly. Installation of a check valve will usually result in short cycling the compressors and may damage the motors and controls and reduce the compressor service life.

NOTICE Do not modify the internal flow path of the compressor unit. Do not modify the access covers or latches. Improper modifications may result in risk of bursting, risk of injury and risk of equipment damage. Do not operate the system with access covers removed, as this will result in the risk of injury due to access to internal moving or hot parts.

NOTICE Do not modify the electric controls or add any auxiliary loads to the electric system that are not part of the original Powerex design. The main power and control power circuits may be damaged by unauthorized loads or modifications resulting in a risk of death or injury or equipment damage.

Control Panel – Display & Input

The Powerex scroll enclosure air compressor has a power control switch and a touch screen or HMI panel on the front to allow operation and monitoring of the unit. See Controls section for details on operating the unit using the touch screen.

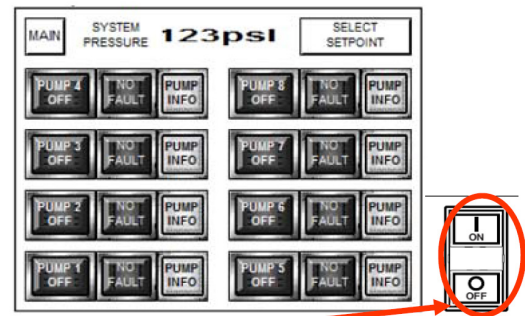

Figure 5

The switch beside the screen controls power to the motor starters. When the system is energized the HMI screen will be lit and the control screen is active, but the motors will not run until the ON button is pushed. When ON is pushed, the center section of the switch will illuminate, enabling the PLC control of the system, and will remain lit until the OFF button is pushed. The OFF button on the switch may be used to stop the compressors at any time. The switch does not turn off power to the panel so be sure to lock out the power source before opening the panel for service.

NOTE: The “Jog” function on the screen overrides the ON switch. The motors will operate if the Jog button is continually depressed. To reach “JOG” press the SYSTEM STATUS button, then press PUMP INFO for the pump module you want to jog.

The PUMP INFO screen is shown below. Press the > arrow button to jog pumps.

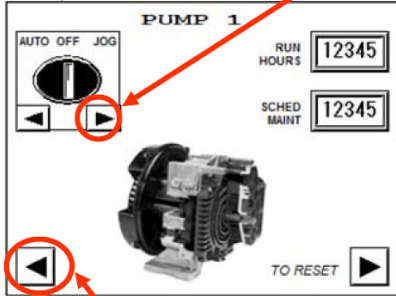

Figure 6

Use the < arrow button to go back and select the next pump.

If the SYSTEM STATUS screen is not visible, go back to the MAIN screen and select SYSTEM STATUS (see below).

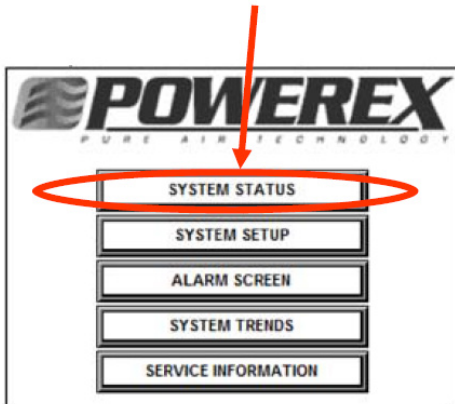

Figure 7

Operation

Before Start Up

1. Make sure all safety warnings, labels and instructions have been read and understood before continuing.
2. Remove any shipping materials, brackets, etc.
3. Confirm that the electric power source and ground have been firmly connected.
4. Check the belts for tightness.
5. Be sure all pressure connections are tight.
6. Check to be certain all safety relief valves etc., are the proper size.
7. Securely mount all panels and guards.
8. Check that all fuses, circuit breakers etc., are the proper size.
9. Make sure the inlet filter is properly installed.
10. Secure the area around the compressor to prevent unauthorized access during this check. Remove the panels so the motor pulley on each set is visible.

NOTICE Check motor rotation before operating the unit.

Turn power on the unit and exercising extreme caution, use the HMI display/input screen to jog each motor. (To reach the JOG function, select SYSTEM STATUS from the MAIN screen, then select PUMP INFO for each installed pump/ motor set). Powerex wires the controls so all motors rotate in the same direction. Correct rotation is CW looking at the basemount, opposite the pulley side. If all or any of the motors rotate incorrectly, lock out the power, correct the input wiring and recheck. If any motor wiring is ever disturbed or modified, recheck each motor for proper rotation direction. Restore the access panels before operating the unit.

Initial Start Up & Set Up of the Control

The control is programmed at the factory and default settings are installed. To access certain control functions you will need to enter a seven digit authorization code. You may select your own code. We recommend using the last seven digits of the unit serial number.

To enter the code, from the SYSTEM STATUS screen touch SELECT SETPOINT.



Figure 8

Go to page 2 of the SELECT SETPOINT screen.

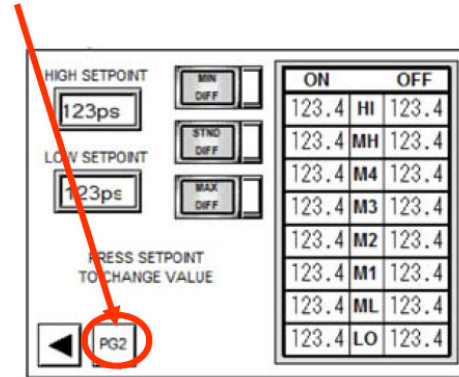

Figure 9

The second page of the SETUP screen will appear.

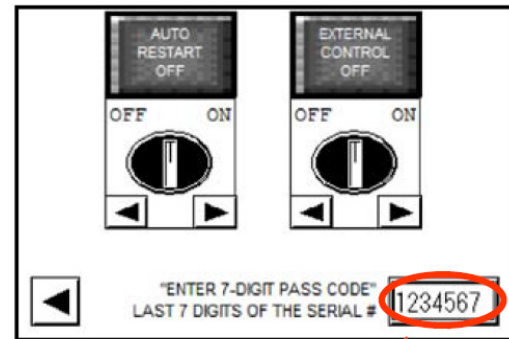

Figure 10

Touch the rectangle to enter the Authorization Code and enter seven digits using the keypad that appears. Powerex suggests using the last seven digits of the serial number.

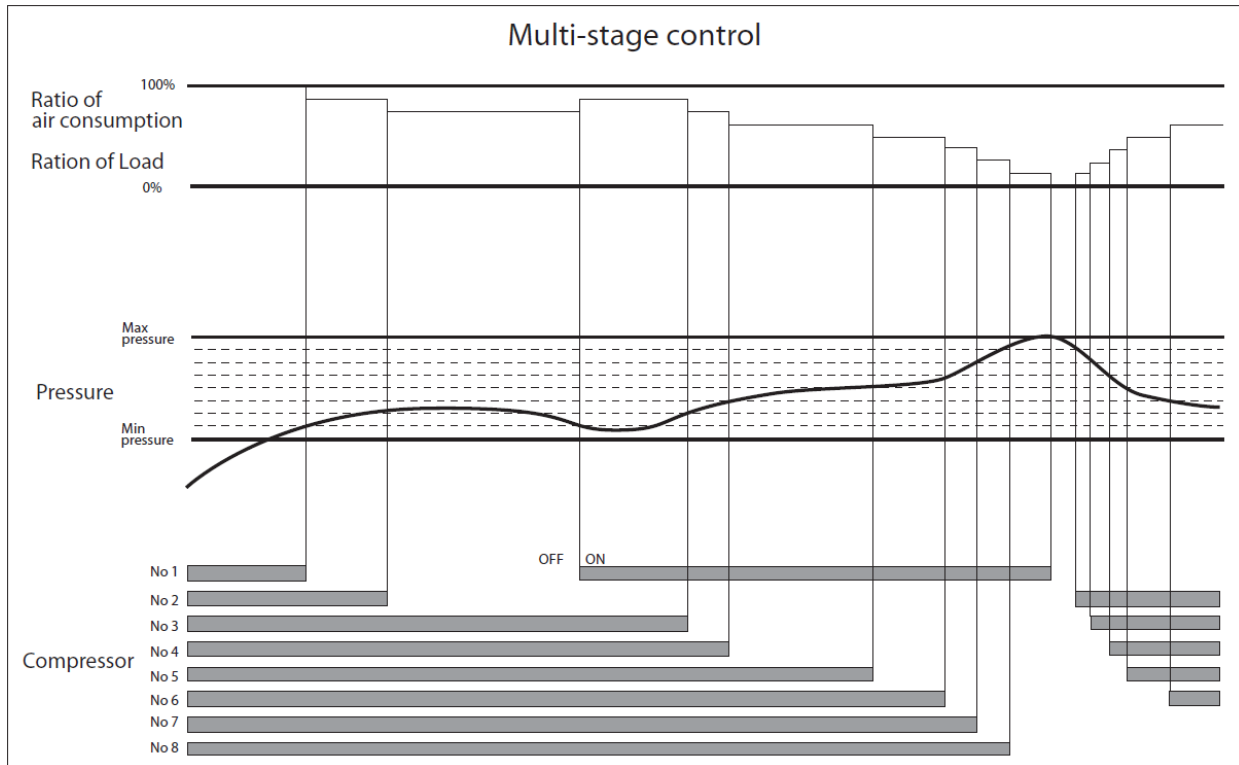

Table 3: The sequence is an example of operation of SEO4007. SEH3007 operate 6 air ends.

Start Up & Operation

1. Follow all the procedures under “Before start-up” before attempting operation of the compressor.
2. Switch on the electric source.
3. Verify the display screen is lit.
4. If an isolation valve is installed between the compressor unit and the air receiver, make sure it is open. Close the isolation valve between the air receiver and the facility piping.
5. Pushing the ON button beside the touch screen will allow the unit to start and operate automatically. Pushing the OFF button will stop the motors, but the HMI screen will remain active.
6. If the pressure does not rise, turn the unit off, the unit is running backwards. Have a qualified electrician switch the breaker OFF and exchange two out of the three phases of electrical source. If pressure is rising, allow the compressor unit to run. Each compressor motor will automatically turn off as the pressure rises and the maximum operating pressure is reached. Pressure settings may be adjusted as described below.
7. Open the isolation valve between the air receiver and the facility piping. The compressor will start and stop each pump as needed to maintain the pressure between the high and low set points.
8. After a few hours and again after a few days, check the display screen to see if the ALARM screen has appeared. If a HIGH TEMPERATURE or MOTOR OVERLOAD condition occurs, the

alarm screen will appear and the affected pump-motor will be taken out of service. If the chosen settings are causing the motors to start too frequently, the ALARM screen will appear and the MOTOR WARNING indicator will illuminate. Motor warning will not take the motor out of service, but the user should take action to prevent motor overload and damage. To reduce motor starting frequency, adjust the set points to a wider range between High and Low and possibly increase the differential. If starting is still too frequent, a larger or additional air receiver will be needed.

Shut Down

1. Stop the compressor by pushing the OFF button.
 - NOTE:** If the compressor rotates in reverse for more than five seconds, the check valve needs to be cleaned or replaced.
2. Switch the breaker OFF if the compressor is not to be used for a long period of time.

Stopping the Compressor During Emergency Operation

Stop the compressor by pushing the OFF button or by turning the power off at the main disconnect panel.

Multi-stage Control

As this compressor uses plural air ends, it employs multi-stage control. It can start and stop each air end according to pressure and air consumption, automatically select the number of air ends in accordance with air consumption and achieve optimum and uniform

operation at all times as well as energy-saving and labor-saving operation.

1. Multi-stage control - Among air ends which are operating under group control, it stops the air end which has been operating for a longer time and restarts the air end whose operating time has been shorter, thus resulting in equalization of operating time of each air end and operation with a min. quantity of air ends in accordance with air consumption and energy-saving operation by eliminating waste of electricity. Table 3 on page 11 shows the relationship between pressure and the quantity of air ends operating for an SEO model. The same concept is applied to 6 air ends for an SEH.
2. Automatic Alteration: When air demand allows one or more air ends to remain idle, the control will automatically shift operation to equalize usage after 10 minutes. If air demand increases and pressure drops, the control will energize additional air ends as needed, starting the one with the longest off time first. The control will also de-energize air ends as pressure rises.
3. The control allows the user to adjust the pressure settings. To minimize power consumption, the user should select the lowest maximum pressure that is suitable for the operations being performed. The smallest gap between minimum and maximum pressure that avoids too frequent motor starting should also be selected.
4. The control will automatically prevent multiple motors from starting simultaneously by inserting a three second delay.

Operating Panel & Settings

The Scroll Enclosure Air Compressor is controlled by a PLC programmed at the Powerex factory. The operating status is displayed on the HMI– touch screen panel on the front of the compressor unit. The touch screen allows the user to select operating parameters within predetermined limits set at the factory. The touch screen also allows the user to change the display to get more information about the operation of the individual compressor modules and to take action based on alarms and warnings. This enclosed scroll system utilizes a PLC for alternation and will change the pump sequence (Lead, Lag1, Lag2 etc) after every start or after 10-minutes, which ever happens first. The HMI offers a MIN and MAX system setpoint and three calculated pressure differential settings. (Standard, Min and Max).

The factory default settings for HIGH and LOW Operating Pressures	
Standard Models	90-116 PSIG
Differential setting default is STANDARD	

Table 4

Limits to difference between HIGH and LOW setpoints are:	
Maximum Differential	50 PSIG
Minimum Differential	16 PSIG

Table 5

The control automatically divides the range between HIGH and LOW Operating Pressure into equal operating intervals. The differential for the operating intervals may be adjusted by selecting STANDARD, MIN or MAX on the set up screen.

In STANDARD, the differential will be automatically set to have a slight overlap between the individual pump intervals. Each interval will be 135% of the possible minimum value.

In MIN, the differential will be automatically set to divide the available range into equal intervals with no overlap. The selection will result in the most frequent starting of the electric motors for a given Operating Pressure range.

NOTE: more frequent motor starting can lead to reduced motor life. Exceeding 17 .5 starts per hour will cause a warning display.

In MAX, the differential will be automatically set to increase the overlap as compared to the Standard setting. Each interval will be 235% of the possible minimum interval. Select this mode to minimize the frequency of motor starts. Motor start frequency can be reduced by using larger air receiver tanks, selecting a wider range between HIGH and LOW Operating Pressure and by selecting the widest differential.

To minimize power consumption, select the lowest possible HIGH operating pressure and the smallest differential that avoids exceeding the motor start frequency limit.

Performing Pressure Adjustments

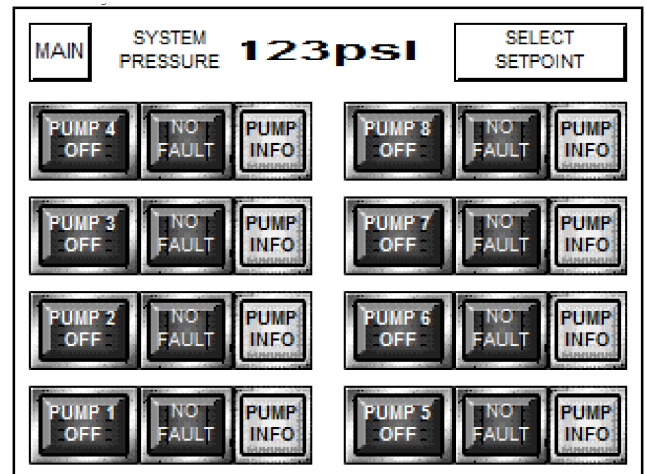

Figure 11

The above display is the SYSTEM STATUS screen. (For the SEH model, only six sets of buttons/indicators; will be shown).

To adjust pressure settings, touch the SELECT SETPOINT button. The screen will change to a display similar to this:

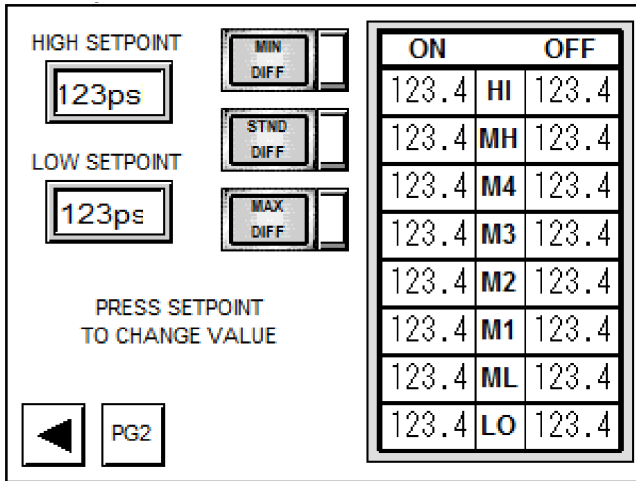

Figure 12

Touch the screen at either the HIGH SETPOINT or LOW SETPOINT button/indicator. A key pad display will be shown.

Enter the desired pressure setting using the key pad and touch ENT.

CLR is clear, use it to backspace one digit.

CAN, or Cancel, voids the whole input, use it to start over.

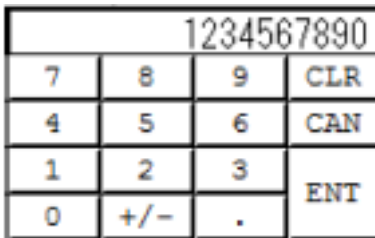

Figure 13

Pressure settings must be entered as whole numbers, no decimal or fractions. The individual intervals will be calculated and shown in the display boxes on the right side of the setting screen. If numbers are entered that are out of the allowed range, the input will be scaled back to the range limit.

Alarm Signals

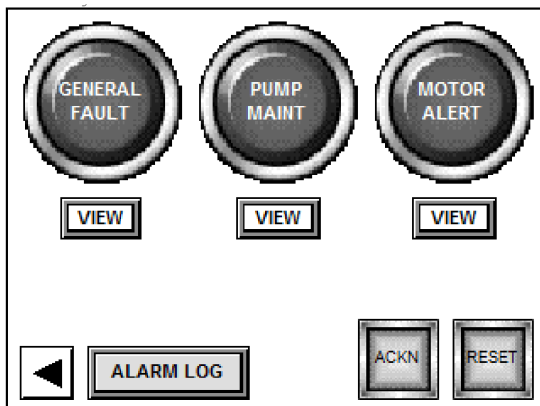

Figure 14

The PLC control for the scroll enclosure compressor will display the ALARM screen and activate the GENERAL FAULT indicator on the alarm screen display if either of the two conditions occurs:

1. High temperature at the sensor located at the after cooler inlet. Each compressor module has its own sensor. A high temperature condition will result in the power to that motor being shut off. The GENERAL FAULT alarm display will stay on and the circuit will stay off even after the sensor cools, and can only be restored when the alarm is cleared by a user. If a high temperature condition occurs, the reason should be determined and corrected before restarting the circuit as unreparable damage to the scroll pump may result from operation with repeated high temperature alarms.
2. Motor Overload, if the current to the motor exceeds the setting of the adjustable motor protector, the contactor associated with that motor is de-energized, and that motor will not run. The alarm display and condition is maintained until the alarm is cleared and the motor protector reset. The circuit will be restarted as needed. If a motor overload occurs, the root cause should be determined and corrected or motor damage may result.

The user can activate the acknowledge function (button labeled ACKN) to allow the display to go back to SYSTEM STATUS or any other screen. Touch the VIEW button to advance to a screen showing which pump-motor assembly is in fault and for what reason. The fault will display and the affected pump-motor will be disabled until the RESET button is pushed.

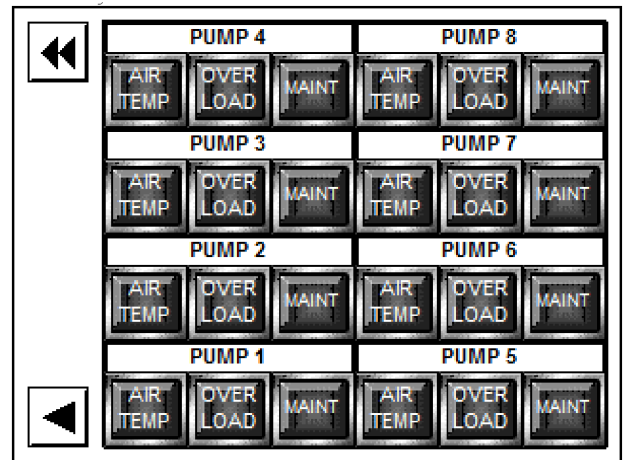

Figure 15

The PUMP MAINT indicator will activate when the running hours of any pump accumulates to a required maintenance interval. The system is designed for multiple pumps to accumulate hours evenly and for maintenance intervals to be approached simultaneously. To prevent nuisance PUMP MAINT indications, all applicable maintenance counters should be reset after the required maintenance actions are performed. Use ACKN to allow the STATUS screen or other screens to be displayed. Touch the VIEW button to advance to the next screen. Consult the maintenance schedule on page 15 and scroll

air compressor manual for details of what maintenance needs to be performed. To reset the PUMP MAINT indicator for an individual pump, open the PUMP INFO screen for that pump, hit the RESET button and use the keypad display to enter the authorization code

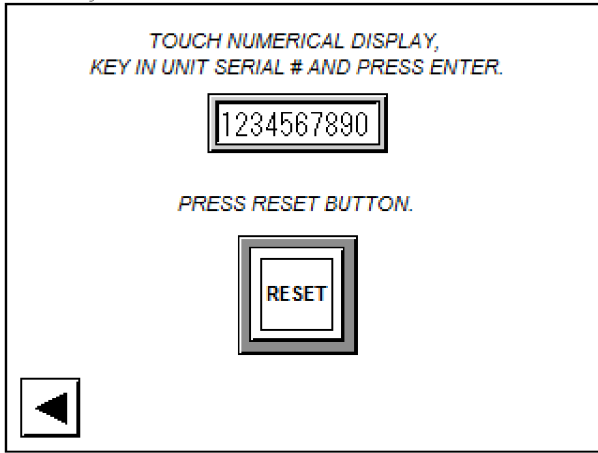

Figure 16

when prompted.

Motor Warning: The control also tracks how many times per hour an individual motor is called on to start. If the starts per hour exceed 17.5, there is an increased risk of motor damage. The warning is displayed, but the system is not shut down. The user can select a wider operating pressure differential to reduce the starts per hour or install a larger air receiver. The ACKN button, which will have to be pressed for each motor in alert, allows the display to be shifted back to SYSTEM STATUS or any other screen before the warning automatically resets itself at the end of the hour. The RESET button will not clear the warning.

Alarm Log

A record of all alarm or warning events is kept in the alarm log. Reset status is tracked as well. The alarm log is maintained as long as the unit is powered and for up to three days after power is removed from the control.

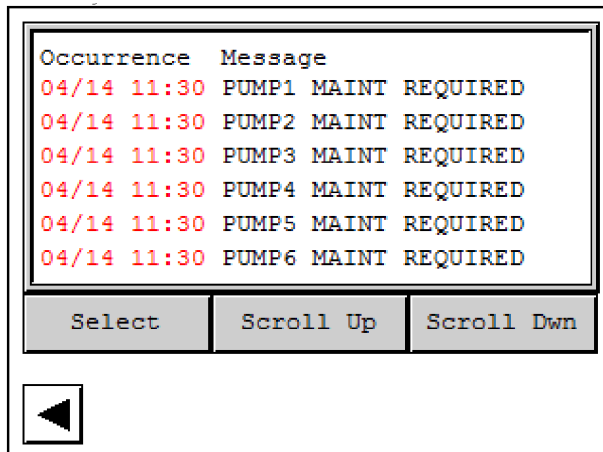

Figure 17

System Trends

The following additional information is available by selecting the SYSTEM TRENDS from the MAIN screen: The control tracks the amount of time the pumps are in use and compares that to the available time. The ratio is displayed. The LOAD FACTOR is displayed for the most recent 24 hour period.

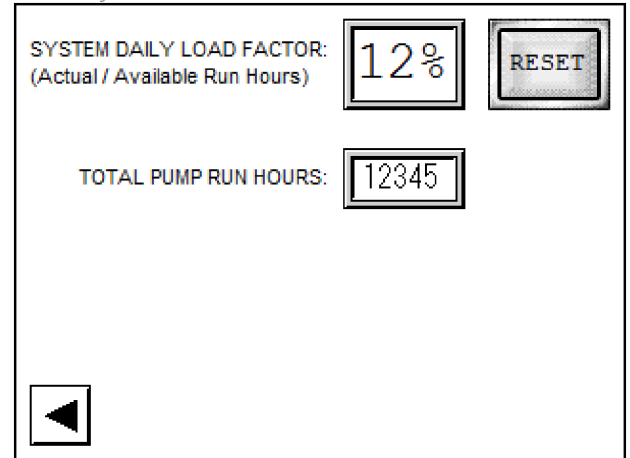

Figure 18

Automatic Restart

When power is applied to the Powerex scroll enclosure compressor control, the display will illuminate and go to the MAIN screen. Settings will be retained from the last time the system had power. The motors will not energize until the ON button is pushed on the control switch beside the display. (Only the JOG function will override the ON button). In the event of a loss of power, the user must push the ON button to restore the compressors to operation. If automatic restart is desired, go to the SYSTEM SETUP screen PG2 and press the > arrow on the left selector switch. To disable, press the < arrow.

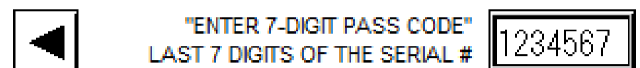
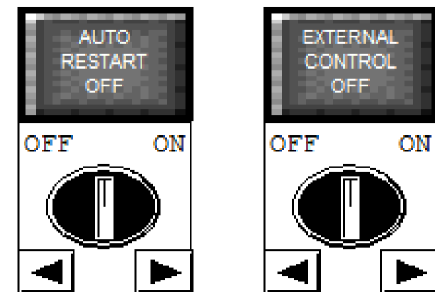

Figure 19

Maintenance

The 7.5 and 10 HP Scroll Enclosed units are constructed with the Powerex patent pending Service Slide feature. Each pump motor baseplate is mounted to a set of rails that are separated from the system frame by anti-vibration pads. The baseplate is constructed so that its mounting brackets may be loosened slightly and the assembly moved on the rails to improve access for regular maintenance and major service or repair. The baseplate assemblies may be moved outwards from the frame set on the motor side. For the top bay in each stack, the instrument panel will need to be removed and set aside to provide clearance. IN some cases it may be more convenient to simply remove the roof panel to provide access.

When performing tip seal and bearing grease maintenance actions, the pumps can be accessed from the left and right side panels. Spacing of the pump bays is sufficient to allow use of the Powerex grease gun , but sliding the set out can be more convenient or a flex hose can be used with the grease gun to facilitate greasing from the side where tip seal access is obtained.

If the Service Slide feature is utilized, it may be beneficial to leave the pump end, belt side, corner bracket to rail, screw just loose enough to slide; rather than clamping it tight. No operational issues will arise and it will facilitate future use of the slide feature.

Maintenance for Multi-stack systems follows. Single stack systems have similar features, but do not have circuit breakers for left-right stack isolation.

Locking Out Potential to Perform Maintenance Procedures

The enclosure is equipped with the components to mechanically and electrically lock out both stacks of pump/motor assemblies. Proper OSHA lockout/tagout procedures should be abided by at all times. Electric potential to each motor can be locked out using the lockable motor protectors. (See Figure 5) Electric potential to the ventilation fans and temperature switches can be locked out using the 4 circuit breakers provided on the control panel. (See Figure 6) Circuit breakers #1 and #3 are associated with the left bank of compressors while #2 and #4 are associated with the right bank. Mechanical potential can be locked out using the lockable ball valves located behind the control panel and are accessible by removing the back center intake panel. (See Figure 7) After closing either ball valve, bleed the remaining line pressure by pulling the provided safety relief's ring to remove all potential within a bank of compressors. Some models do not include locking ball valves and require locking covers for secure isolation.

Adjusting Belt Tension

⚠ DANGER *Moving Parts! Lock out power before servicing unit!*

After the first 200 to 500 running hours or at any time chirping is heard on start up, check the belt tension. If tension is below 25 pounds on any belt, increase the center distance using the motor slide base so that belt tension is 45 to 50 pounds. The motor slide base details are shown below. If installing new belts see the procedure below:

New Belt Installation Procedure

1. Loosen the two slide bolts near the motor pulley and the two slide bolts on the front edge of the base. Keep enough torque on them to take up any slack between the slider and the main base, but enough slack to allow the slider to move.
2. Tighten the belt adjustment bolt using a torque wrench to 45 inch pounds. This will bring the belts to the proper tension.
3. Tighten the slider bolts, the two on the front edge of the base, then the two slider bolts closest to the motor pulley so the belt tension is 45 to 50 pounds.

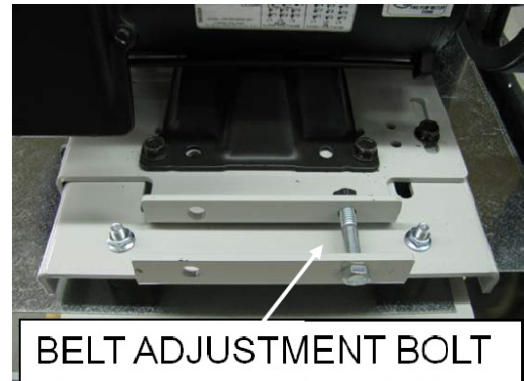

Figure 20

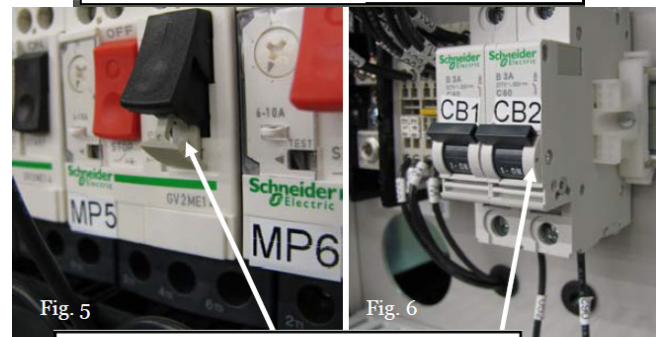

Figure 21

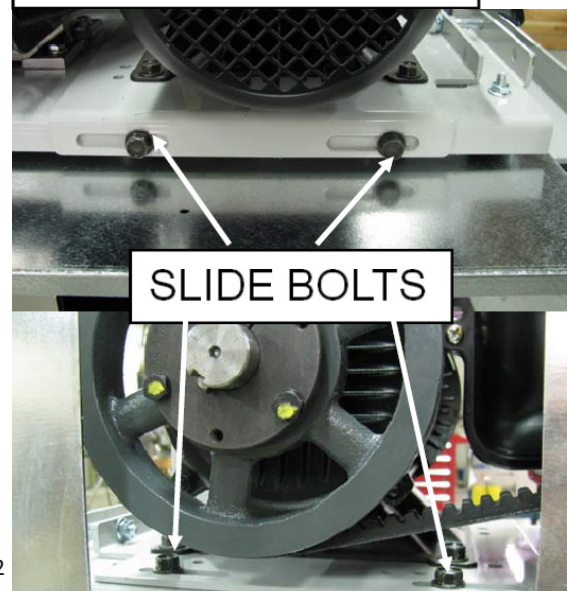

Figure 22

Outline drawing shows location of isolation valves near after coolers on multi stack models. One valve is provided for each pump. Close all valves when isolating and locking a "stack".

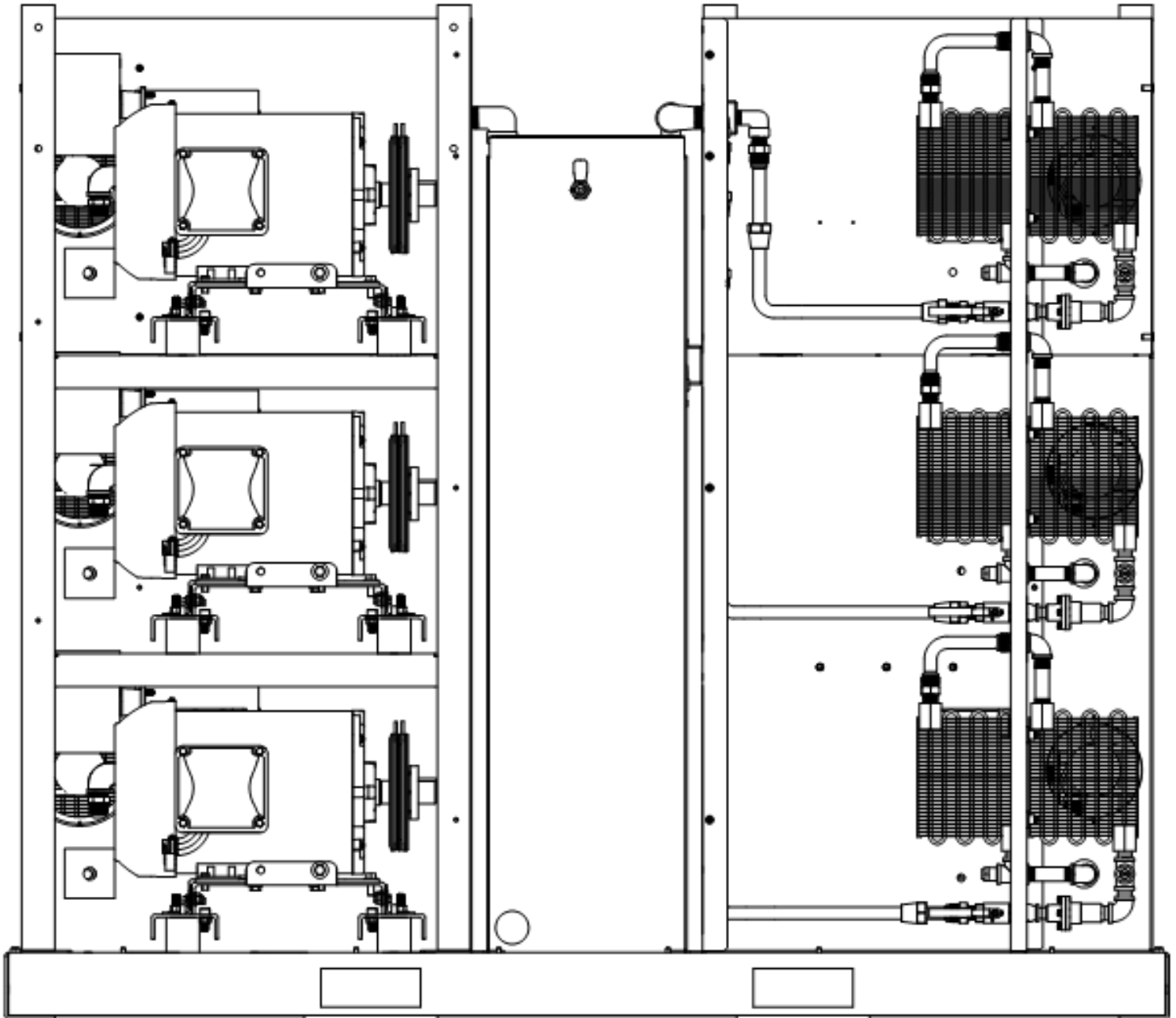

Figure 23

Maintenance Schedule

Item	Action needed	Operating Hours					Remarks
		500	2000	4000	8000	16000	
Intake Filter	Replace	●	▲				Every 2000 hours or less
Ventilation Screen	Clean	●					Every 500 hours or less
Air End/Blower Fan	Clean			●			Every 4000 hours or less
Fan Duct	Clean			●			Every 4000 hours or less
Compressor Fins	Clean		●				Every 2000 hours or less
Compressor	Grease				▲	Replace pump ▲	Use genuine Powerex grease
Tip Seal	Replace				▲		
Dust Seal	Inspect, Replace				▲		
V-Belt	Inspect, Replace	*	●	▲	▲		*Readjust
Pressure Sensor	Confirm Operation				●		Check touchscreen for pressure rise and fall
Magnetic Starter	Inspect				●		Replace if contact points are deteriorated/ excessive arching
Check Valve	Inspect	●			▲		Confirm operation by watching pump and motor shut off and stop turning
Safety Valve	Confirm Operation						Every 500 hours or less. Pull ring to make sure not stuck or plugged
Ventilation Fan	Inspect		●				Confirm ventilation air is exiting cabinet
Motor Pulley	Inspect Groove/ Make sure tight on shaft				●		Replace if abnormal wear is detected
Motor	Inspect				●	●	Replace if abnormal noise is detected/Make sure electrical
Intake Hose	Inspect		●				Replace if damaged or deteriorating
Braided Hose	Inspect, Replace		●				Make sure there are no leaks
Aftercooler	Clean outside			●			Every 4000 hours or less
Operating Panel	Inspect monitor daily						Verify pressure/Check for alarm notification
Piping	Inspect for leaks		●				Every 2000 hours or less

- Inspect
- ▲ Replace or perform action

- Notes:**
- Inspect and perform maintenance periodically according to the maintenance schedule.
 - The maintenance schedule relates to the normal operating conditions. If the circumstances and load condition are adverse, shorten the cycle time and perform maintenance accordingly.
 - Marked “*Readjust” means the tension of the V-belt should be adjusted during the initial stage and inspected every 2500 hours afterwards.

IMPORTANT:

- Above maintenance intervals are based on conditions where the ambient temperature is around 86°F. If the temperature is higher or running conditions are more severe, shorten above maintenance period by approximately 30% from above recommended run hours for every 8°F increase in ambient temperature.
- Recommended maintenance period and pump warranty period may not coincide depending on the run hours and longevity of your pump.

Troubleshooting Guide

	Problem	Possible Cause	Corrective Action
Compressor does not operate	No display on the operating panel	<ol style="list-style-type: none"> 1. The electric source is not turned on 2. Transformer primary or secondary fuse open 3. Electric source is not correctly connected 4. Failure of display or PLC 	<ol style="list-style-type: none"> 1. Turn on electric source 2. Replace 3. Connect correctly 4. Inspect, repair or replace
	It does not operate despite displays	<ol style="list-style-type: none"> 1. Failure or wiring failure of magnetic starter 2. Motor failure 3. Low voltage 	<ol style="list-style-type: none"> 1. Inspect, repair or replace 2. Inspect, repair or replace 3. Check electric source capacity and the size of electric source cable and change to proper one
	Alarm screen active	<ol style="list-style-type: none"> 1. High temperature condition 2. Motor Overload condition 3. High temperature indicated but unit is cool, has never been hot 	<ol style="list-style-type: none"> 1. Allow to cool and reset, determine cause 2. Reset motor overload, reset alarm and determine root cause of overload 3. A temperature switch may be disconnected or defective, check wiring
Compressor starts but then stops	Alarm screen high temperature	<ol style="list-style-type: none"> 1. High ambient temperature or bad ventilation 2. Clogging of aftercooler fins or intake wire screen 3. Failure of ventilating fan 4. Damage to intake hose 5. Cooling passage of air end clogged 6. High exhaust pressure 7. Circuit breakers are open 	<ol style="list-style-type: none"> 1. Improve installation environment & ventilation 2. Clean 3. Replace 4. Replace 5. Inspect and clean 6. Inspect – possible transducer failure 7. Inspect cause and close
	Alarm screen motor overload	<ol style="list-style-type: none"> 1. Low voltage 2. Motor Failure 3. Air end failure 4. Loosened wiring screw 5. High exhaust pressure 6. Failure of thermal overload 	<ol style="list-style-type: none"> 1. Check electric source capacity, size of electric source cable and change to proper gauge 2. Inspect, repair or replace, verify overload at proper setting 3. Inspect, repair or replace, verify maintenance at proper intervals 4. Tighten, after power supply has been locked out per OSHA 5. Inspect – possible transducer failure 6. Replace, contact points could be corroded on contactor
	System pressure does not increase	<ol style="list-style-type: none"> 1. Air leaks from exhaust piping 2. Air-end rotates backward 3. Air demand higher than compressor output 4. Clogged intake filter 	<ol style="list-style-type: none"> 1. Inspect, repair plumbing, check for open or malfunctioning drain valve 2. Change phases, verify check valves ok 3. Evaluate facility demand 4. Clean or replace
	Safety valve activates	<ol style="list-style-type: none"> 1. Failure of safety valve 2. Failure of pressure setting 	<ol style="list-style-type: none"> 1. Replace 2. Inspect – possible pressure transducer failure
	Abnormal sound	<ol style="list-style-type: none"> 1. Air-end rotates backward after it shuts off. 2. Air end failure 3. Belt slips 4. Motor failure 5. Cooling fan contacting frame 6. Loosened bolts 	<ol style="list-style-type: none"> 1. Defective check valve, replace 2. Inspect, repair, or replace 3. Check tension and readjust 4. Inspect, repair, or replace 5. Inspect and repair 6. Inspect and tighten

Electrical Diagram

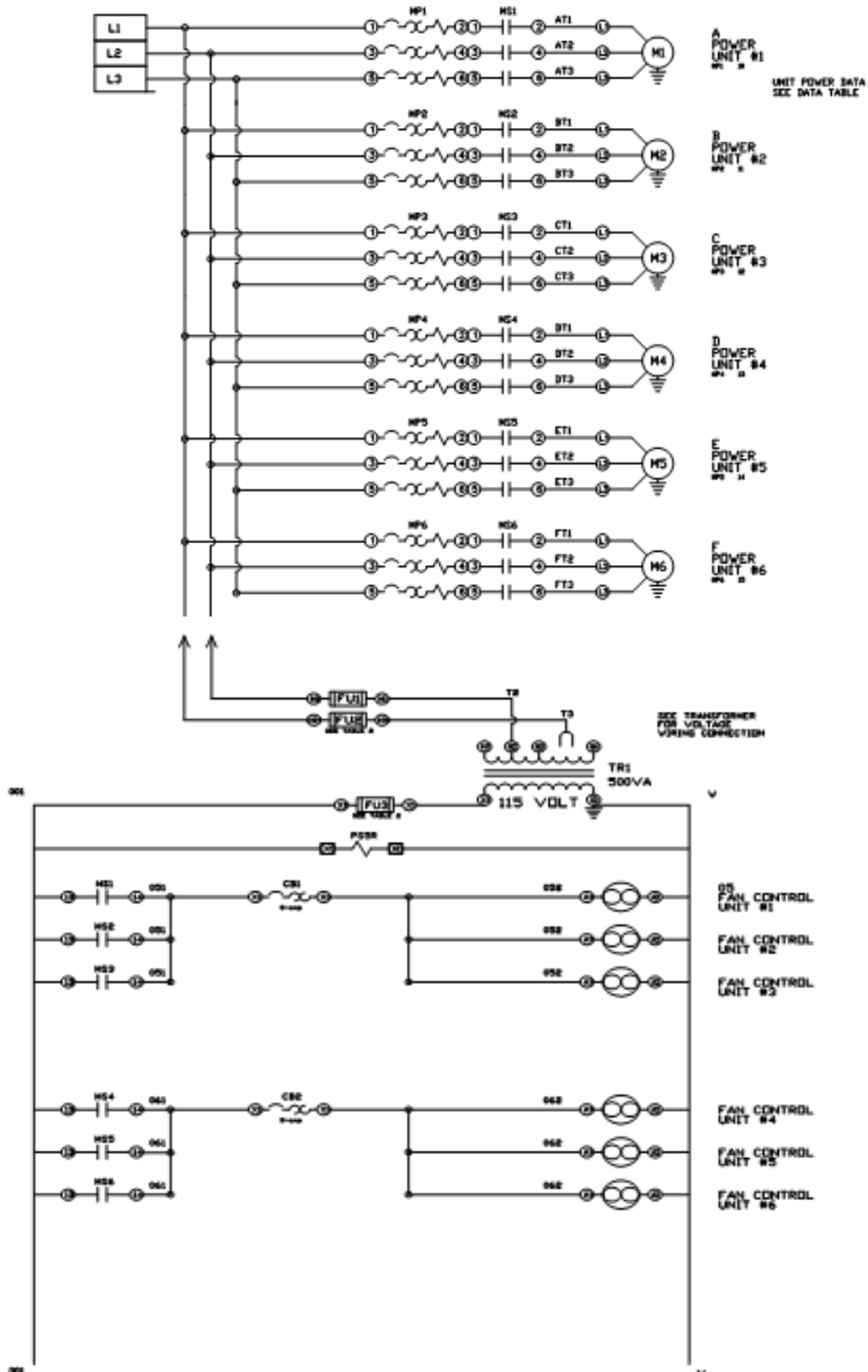

Electrical Diagram

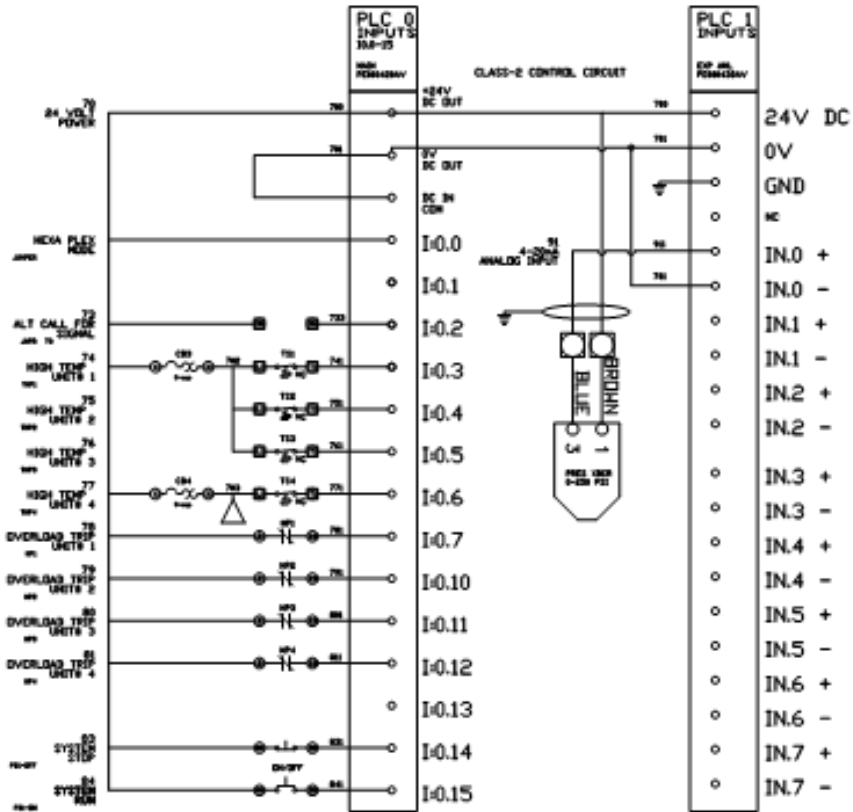

CLASS-2 CONTROL CIRCUIT

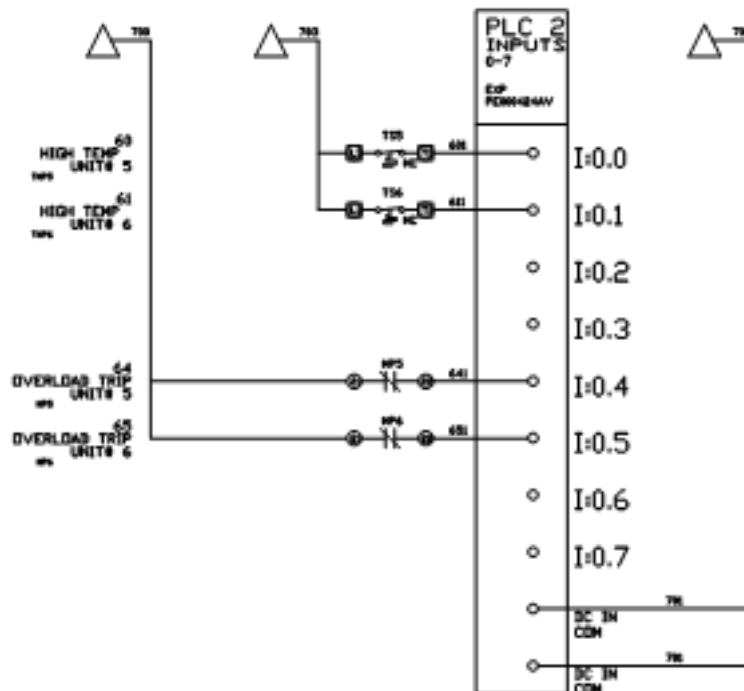

Electrical Diagram

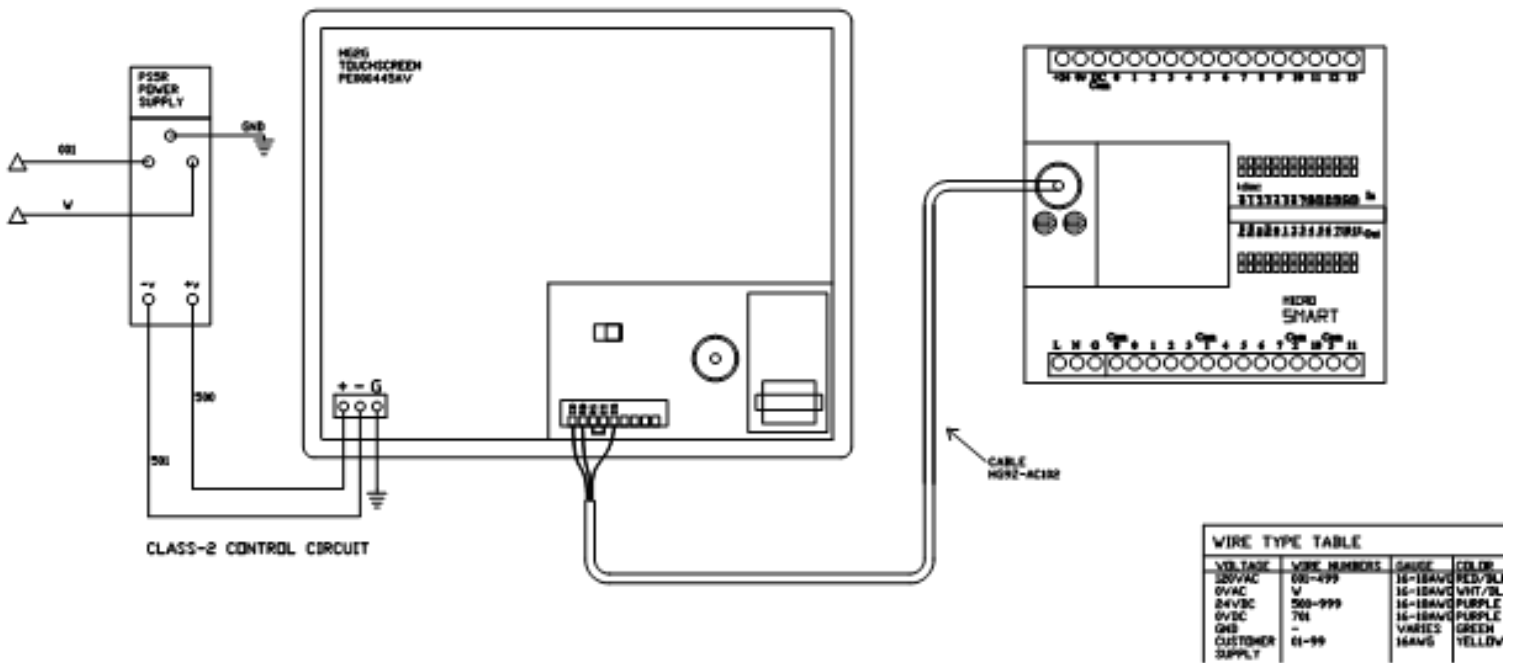

CONTROL PANEL TERMINAL BLOCKS

TOP SECTION

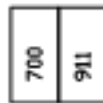
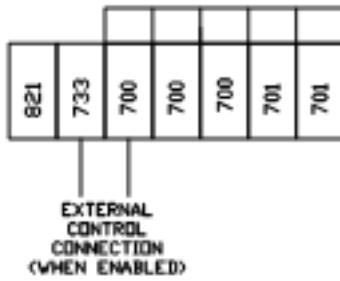

BOTTOM SECTION

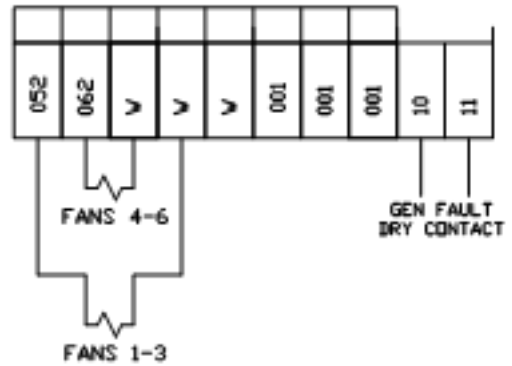

Electrical Diagram

FOR ELECTRICAL ISOLATION OF PUMPS 1-4
TURN OFF CIRCUIT BREAKERS #1 AND #3,
AND TURN OFF MP1, MP2, MP3, AND MP4.
THEN PLACE LOCK OR TAG ON EACH DEVICE.

FOR ELECTRICAL ISOLATION OF PUMPS 5-8
TURN OFF CIRCUIT BREAKERS #2 AND #4,
AND TURN OFF MP5, MP6, MP7, AND MP8.
THEN PLACE LOCK OR TAG ON EACH
DEVICE.

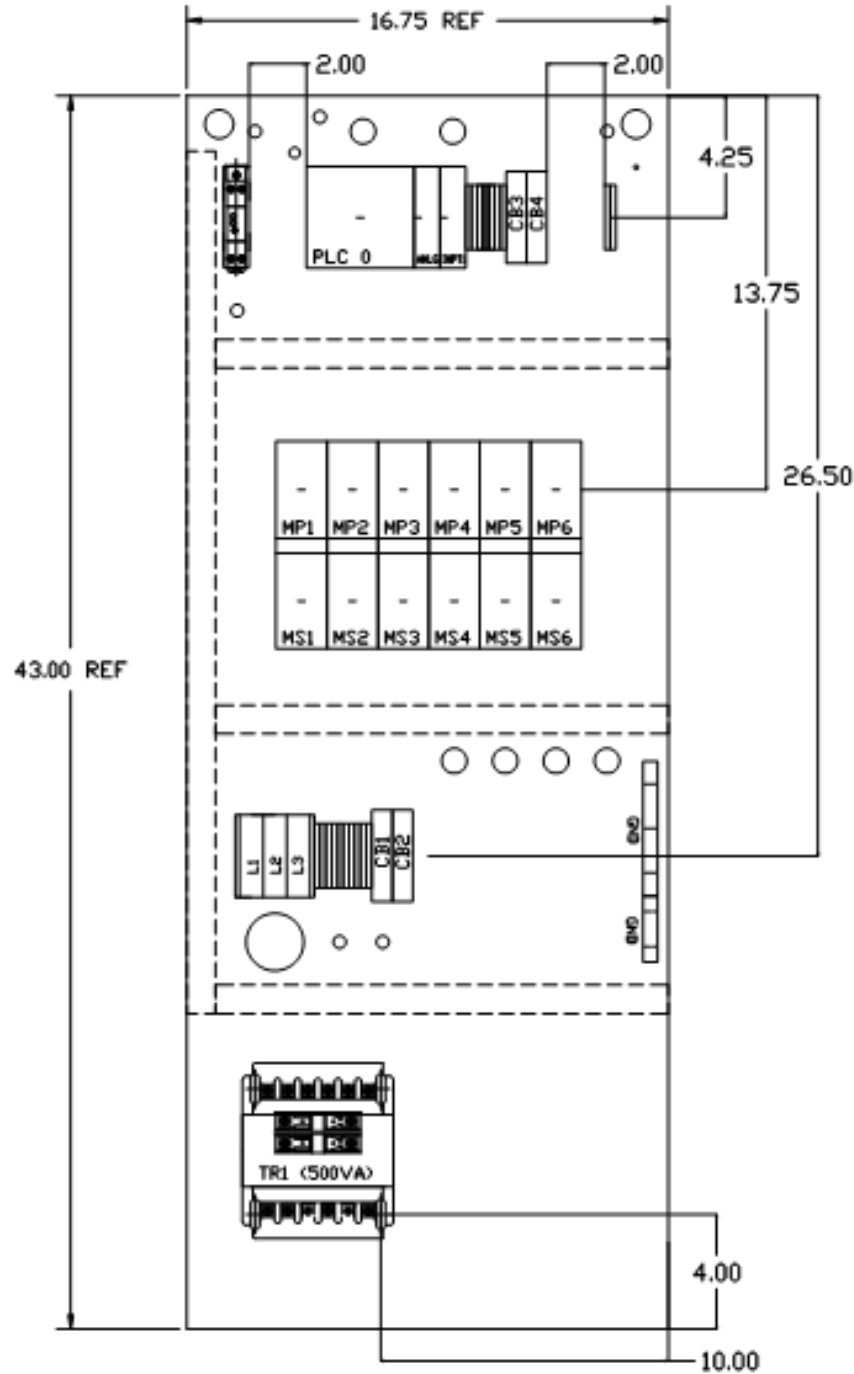

NOTICE For some Medical Systems Models a three phase disconnect is installed on the Scroll Enclosed Unit.

Parts Diagram

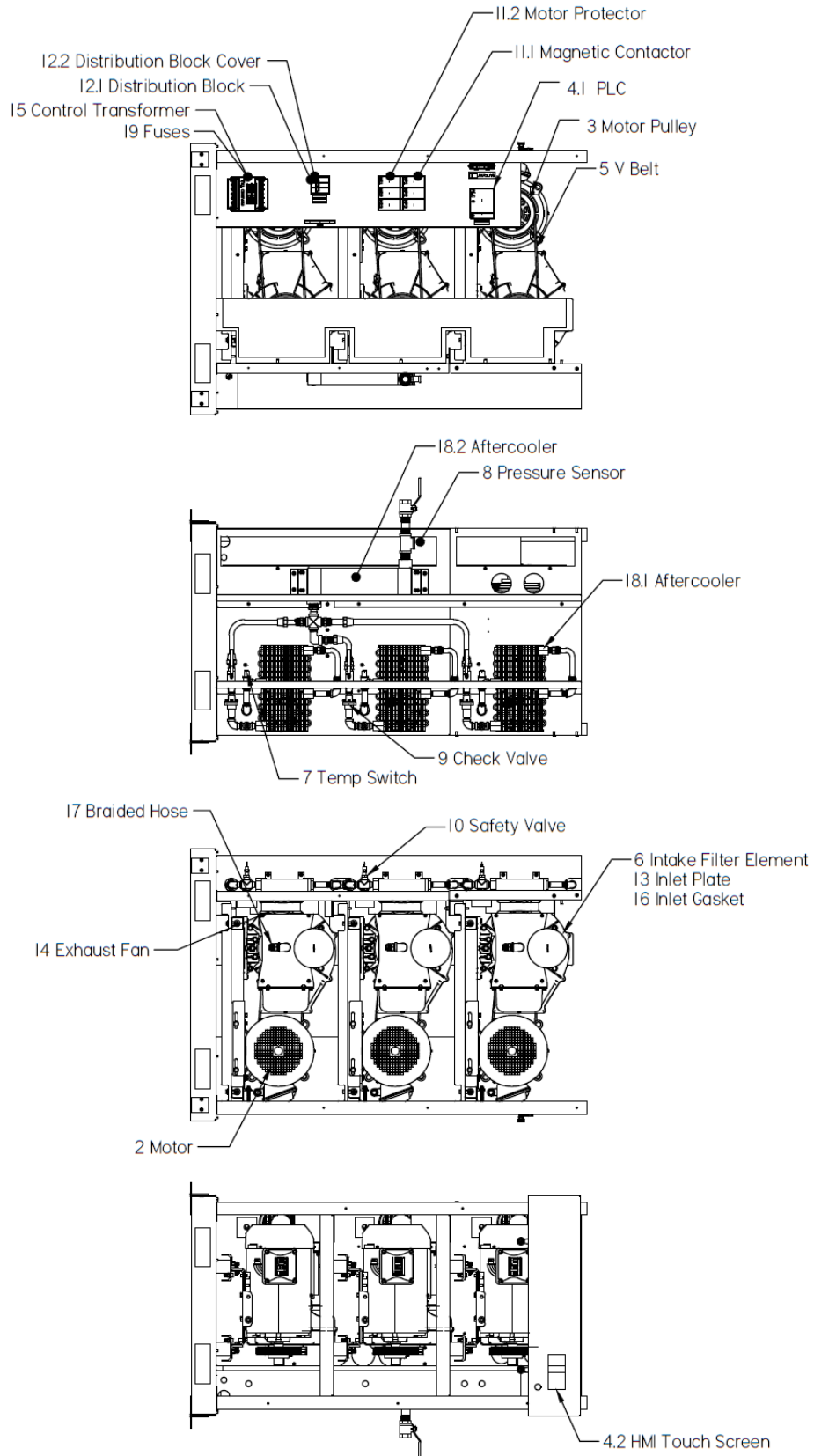

Replacement Parts List

Ref #	Description	15 HP SED15B	QTY	20 HP SED20B	QTY	22.5 HP SET225	QTY	30 HP SET30B	QTY
1	Air End	SL020500AJ	2	SL02100AJ	2	SL020500AJ	3	SL2100AJ	3
2	Motor 208-230/460V	MC304233AV	2	MC304235AV	2	MC304233AV	3	MC304235AV	3
3	Motor Pulley	PU202649AV	2	PU202648AV	2	PU202649AV	3	PU202648AV	3
4.1	PLC	PE000420AJ	1	PE000420AJ	1	PE000420AJ	1	PE000420AJ	1
4.2	HMI Touch Screen	PE000417AJ	1	PE000417AJ	1	PE000417AJ	1	PE000417AJ	1
5	3VX-belt	BT024000AV	4	BT023900AV	4	BT024000AV	6	BT023900AV	6
6	Intake Filter Element	ST073907AV	2	ST073907AV	2	ST073907AV	3	ST073907AV	3
7	Temp Switch	AM003032AV	2	AM003032AV	2	AM003032AV	3	AM003032AV	3
8	Pressure Sensor	ZZ005927AJ	1	ZZ005927AJ	1	ZZ005927AJ	1	ZZ005927AJ	1
9	Check Valve	CV-158	2	CV-158	2	CV-158	3	CV-158	3
10	Safety Valve	V-215400AV	3	V-215400AV	2	V-215400AV	3	V-215400AV	3
11.1	Magnetic Contactor 208V	PE000104AV	2	PE000104AV	2	PE000104AV	3	PE000104AV	3
	230V	PE000103AV	2	PE000104AV	2	PE000103AV	3	PE000104AV	3
	460V	PE000102AV	2	PE000102AV	2	PE000102AV	3	PE000102AV	3
11.2	Motor Protector 208V	PE000309AV	2	PE000310AV	2	PE000309AV	3	PE000310AV	3
	230V	PE000308AV	2	PE000310AV	2	PE000308AV	3	PE000310AV	3
	460V	PE000306AV	2	PE000307AV	2	PE000306AV	3	PE000307AV	3
12.1	Distribution Block	PE000622AV	1	PE000622AV	1	PE000622AV	1	PE000622AV	1
12.2	Distribution Block Cover	PE000640AV	1	PE000640AV	1	PE000640AV	1	PE000640AV	1
13	Inlet Plate	IP638900AV	2	IP638900AV	2	IP638900AV	3	IP638900AV	3
14	Exhaust Fan	SL057006AV	2	SL057006AV	2	SL057006AV	3	SL057006AV	3
15	Control Transformer 208-230/460V	PS005850AV	1	PS005850AV	1	PS005850AV	1	PS005850AV	1
16	Inlet Gasket	IP639000AV	2	IP639000AV	2	IP639000AV	3	IP639000AV	3
17	Braided Hose	SM008108AV	2	SM008108AV	2	SM008108AV	3	SM008108AV	3
18.1	Aftercooler	SM008111AV	4	SM008111AV	4	SM008111AV	6	SM008111AV	6
18.2	Aftercooler	SL057003AV	1	SL057003AV	1	SL057003AV	1	SL057003AV	1
19.1	Primary Fuses 208V	JP007710AV	2	JP007710AV	2	JP007710AV	2	JP007710AV	2
19.2	Primary Fuses 230/460V	JP007714AV	2	JP007714AV	2	JP007714AV	2	JP007714AV	2
19.3	Secondary Fuse 208-460V	JP007715AV	1	JP007715AV	1	JP007715AV	1	JP007715AV	1

Parts Diagram

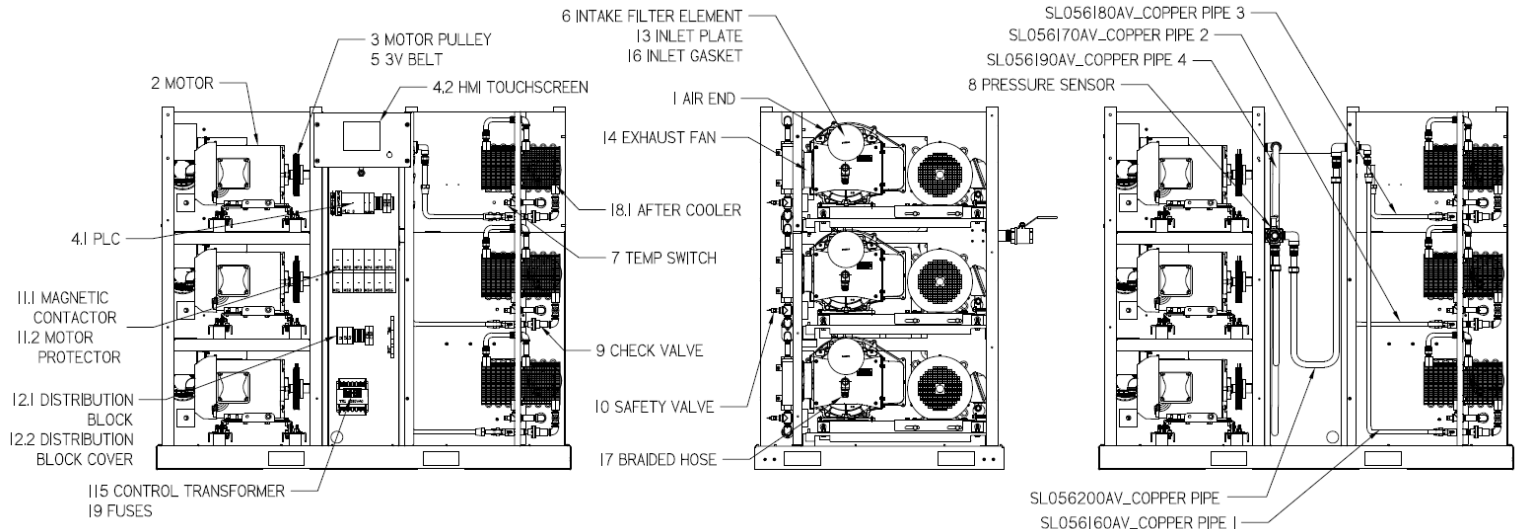

Replacement Parts List

Ref #	Description	40 HP SEQ40BB	QTY	45 HP SEH45B	QTY	50 HP SEP50B	QTY	60 HP SEH60B	QTY
1	Air End	SL02100AJ	4	SL020500AJ	6	SL2100AJ	5	SL2100AJ	6
2	Motor 208-230/460V	MC304235AV	4	MC304233AV	6	MC304235AV	5	MC304235AV	6
3	Motor Pulley	PU202648AV	4	PU202649AV	6	PU202648AV	5	PU202648AV	6
4.1	PLC	PE000420AJ	1	PE000420AJ	1	PE000420AJ	1	PE000420AJ	1
4.2	HMI Touch Screen	PE000445AJ	1	PE000445AJ	1	PE000445AJ	1	PE000445AJ	1
5	3VX-belt	BT023900AV	8	BT024000AV	12	BT023900AV	10	BT023900AV	12
6	Intake Filter Element	ST073907AV	4	ST073907AV	6	ST073907AV	5	ST073907AV	6
7	Temp Switch	AM003032AV	4	AM003032AV	6	AM003032AV	5	AM003032AV	6
8	Pressure Sensor	ZZ005927AJ	1	ZZ005927AJ	1	ZZ005927AJ	1	ZZ005927AJ	1
9	Check Valve	CV-158	4	CV-158	6	CV-158	5	CV-158	6
10	Safety Valve	V-215400AV	4	V-215400AV	6	V-215400AV	5	V-215400AV	6
11.1	Magnetic Contactor 208V	PE000104AV	4	PE000104AV	6	PE000104AV	5	PE000104AV	6
	230V	PE000104AV	4	PE000103AV	6	PE000104AV	5	PE000104AV	6
	460V	PE000102AV	4	PE000102AV	6	PE000102AV	5	PE000102AV	6
11.2	Motor Protector 208V	PE000310AV	4	PE000309AV	6	PE000310AV	5	PE000310AV	6
	230V	PE000310AV	4	PE000308AV	6	PE000310AV	5	PE000310AV	6
	460V	PE000307AV	4	PE000306AV	6	PE000307AV	5	PE000307AV	6
12.1	Distribution Block	PE000622AV	1	PE000622AV	1	PE000622AV	1	PE000622AV	1
12.2	Distribution Block Cover	PE000640AV	1	PE000640AV	1	PE000640AV	1	PE000640AV	1
13	Inlet Plate	IP638900AV	4	IP638900AV	6	IP638900AV	5	IP638900AV	6
14	Exhaust Fan	SL057006AV	4	SL057006AV	6	SL057006AV	5	SL057006AV	6
15	Control Transformer 208-230/460V	PS005850AV	1	PS005850AV	1	PS005850AV	1	PS005850AV	1
16	Inlet Gasket	IP639000AV	4	IP639000AV	6	IP639000AV	5	IP639000AV	6
17	Braided Hose	SM008108AV	4	SM008108AV	6	SM008108AV	5	SM008108AV	6
18	Aftercooler	SM008111AV	8	SM008111AV	12	SM008111AV	10	SM008111AV	12
19.1	Primary Fuses 208V	JP007710AV	2	JP007710AV	2	JP007710AV	2	JP007710AV	2
19.2	Primary Fuses 230/460V	JP007714AV	2	JP007714AV	2	JP007714AV	2	JP007714AV	2
19.3	Secondary Fuse 208-460V	JP007715AV	1	JP007715AV	1	JP007715AV	1	JP007715AV	1

Notes

Notes

Powerex Limited Warranty – Applicable to Non-OEM Customers in the U.S. & Canada Only

Warranty and Remedies.

(a) General. Powerex warrants each Compressor System, Vacuum System, Vacuum Pump, Compressor Air-End, or Powerex branded Accessory (collectively “Products”, individually each a “Product”) to be free from defects in material and workmanship (“Defects”) at the date of shipment. This warranty shall apply only to Products that are purchased and used in the United States of America and in Canada. EXCEPT AS SET FORTH BELOW, NO OTHER WARRANTY, WHETHER EXPRESS OR IMPLIED, INCLUDING ANY WARRANTY OF MERCHANTABILITY OR FITNESS FOR A PARTICULAR PURPOSE, SHALL EXIST IN CONNECTION WITH THE SALE OR USE OF SUCH PRODUCTS. TO THE EXTENT PERMITTED BY LAW, ANY AND ALL IMPLIED WARRANTIES ARE EXCLUDED. All warranty claims must be made in writing and delivered to Powerex in accordance with the procedures set forth on its website (www.powerexinc.com), or such claim shall be barred. Upon timely receipt of a warranty claim, Powerex shall inspect the Product claimed to have a Defect, and Powerex shall repair, or, at its option, replace, free of charge, any Product which it determines to have had a Defect; provided, however, that if circumstances are such as to preclude the remedying of Defect by repair or replacement, Powerex shall, upon return of the Product, refund to buyer any part of the purchase price of such Products paid to Powerex. Freight for returning Products to Powerex for inspection shall be paid by buyer. The warranties and remedies herein are the sole and exclusive remedy for any breach of warranty or for any other claim based on any Defect, or non-performance of the Products, whether based upon contract, warranty or negligence.

(b) (i) Standard Period of Warranty – Parts and Labor. The purchase of any system includes our standard warranty. Powerex warrants and represents all Products shall be free from Defects for the first eighteen (18) months from the date of shipment by Powerex, or twelve (12) months from the documented date of startup, or five thousand (5,000) hours of use, whichever occurs first. During such warranty period, Powerex shall be fully liable for all Defects in the Products (the “Product Defects”), i.e., all costs of repair or replacement, which may include “in and out” charges, so long as the Products are located in the United States or Canada, and the Products are reasonably located and accessible by service personnel for removal. “In and out” charges include the costs of removing a Product from buyer’s equipment for repair or replacement.

(ii) Premium Period of Warranty – Parts and Labor. In order to be eligible for premium warranty coverage, a premium warranty for each system must be purchased when order is placed. Powerex warrants and represents all Products shall be free from Defects for the first thirty (30) months from the date of shipment by Powerex, or twenty-four (24) months from the documented date of startup, or seven thousand five hundred (7,500) hours of use, whichever occurs first. During such warranty period, Powerex shall be fully liable for all Defects in the Products (the “Product Defects”), i.e., all costs of repair or replacement, which may include “in and out” charges, so long as the Products are located in the United States or Canada, and the Products are reasonably located and accessible by service personnel for removal. “In and out” charges include the costs of removing a Product from buyer’s equipment for repair or replacement.

(c) Additional Period of Warranty – Parts Only (No Labor). In addition to the above, Powerex warrants each Powerex branded Compressor Air- End and Vacuum Pump shall be free of Defects for a period of forty-two (42) months from the date of shipment by Powerex, or thirty-six (36) months from the documented date of startup, or ten thousand (10,000) hours of use, whichever occurs first. Supplier’s repair or replacement of any Product shall not extend the period of any warranty of any Product. This warranty applies to the exchange of part(s) found to be defective by an Authorized Powerex Service Representative only.

(d) Replacement Pumps – Parts Only (No Labor). For any replacement Air-End or Vacuum Pumps installed on a Powerex manufactured system or unit after any initial warranty period has expired or where another warranty does not apply for any reason, Powerex warrants that the Air-End or Vacuum Pumps shall be free of Defects for a period of thirty-six (36) months from the date of shipment by Powerex or ten thousand (10,000) hours of use, whichever comes first. For any replacement Air-End or Vacuum Pumps installed on a system that was not manufactured by Powerex after any initial warranty period has expired or where another warranty does not apply for any reason, Powerex warrants that the Air-End or Vacuum Pumps shall be free of Defects for the first twelve (12) months from the date of shipment by Powerex. Supplier’s repair or replacement of any Product shall not extend the period of any warranty of any Product. This warranty applies to the exchange of part(s) found to be defective by an Authorized Powerex Service Representative only.

(e) Replacement Motors – Parts Only (No Labor). For any replacement motor installed on a Powerex manufactured system or unit after any initial warranty period has expired or where another warranty does not apply for any reason, Powerex warrants that the replacement motor shall be free of Defects for the first twelve (12) months from the date of shipment by Powerex. For any replacement motor installed on a system or unit that was not manufactured by Powerex after any initial warranty period has expired or where another warranty does not apply for any reason, Powerex warrants that the replacement motor shall be free of Defects for the first ninety (90) days from the date of shipment by Powerex. Supplier’s repair or replacement of any Product shall not extend the period of any warranty of any Product. This warranty applies to the exchange of part(s) found to be defective by an Authorized Powerex Service Representative only.

(f) Replacement Parts – Parts Only (No Labor). For other replacement parts besides motors, Air-End or Vacuum Pumps installed on a Powerex manufactured system or unit after any initial warranty period has expired or where another warranty does not apply for any reason, Powerex

warrants that such replacement parts will be free from Defects for the first twelve (12) months from the date of shipment by Powerex. For other replacement parts besides motors, Air-End or Vacuum Pumps installed on a system or unit that was not manufactured by Powerex after any initial warranty period has expired or where another warranty does not apply for any reason, Powerex warrants that such replacement parts will be free from Defects for the first twelve (12) months from the date of shipment by Powerex. For other replacement parts besides motors, Air-End or Vacuum Pumps installed on a system or unit that was not manufactured by Powerex after any initial warranty period has expired or where another warranty does not apply for any reason, Powerex makes no warranties. Supplier's repair or replacement of any Product shall not extend the period of any warranty of any Product. This warranty applies to the exchange of part(s) found to be defective by an Authorized Powerex Service Representative only.

(g) Coverage. The warranty provided herein applies to Powerex manufactured units or systems only.

(h) Exceptions. Notwithstanding anything to the contrary herein, Powerex shall have no warranty obligations with respect to Products:

(i) That have not been installed in accordance with Powerex's written specifications and instructions;

(ii) That have not been maintained in accordance with Powerex's written instructions;

(iii) That have been materially modified without the prior written approval of Powerex; or

(iv) That experience failures resulting from operation, either intentional or otherwise, in excess of rated capacities or in an otherwise improper manner.

The warranty provided herein shall not apply to: **(i)** any defects arising from corrosion, abrasion, use of insoluble lubricants, or negligent attendance to or faulty operation of the Products; **(ii)** ordinary wear and tear of the Products; or **(iii)** defects arising from abnormal conditions of temperature, dirt or corrosive matter; **(iv)** any OEM component which is shipped by Powerex with the original manufacturer's warranty, which shall be the sole applicable warranty for such component.

Limitation of Liability. NOTWITHSTANDING ANYTHING TO THE CONTRARY HEREIN, TO THE EXTENT ALLOWABLE UNDER APPLICABLE LAW, UNDER NO CIRCUMSTANCES SHALL POWEREX BE LIABLE FOR ANY INCIDENTAL, CONSEQUENTIAL, PUNITIVE, SPECULATIVE OR INDIRECT LOSSES OR DAMAGES WHATSOEVER ARISING OUT OF OR IN ANY WAY RELATED TO ANY OF THE PRODUCTS OR GOODS SOLD OR AGREED TO BE SOLD BY POWEREX TO BUYER. TO THE EXTENT ALLOWABLE UNDER APPLICABLE LAW, POWEREX'S LIABILITY IN ALL EVENTS IS LIMITED TO, AND SHALL NOT EXCEED, THE PURCHASE PRICE PAID.

Warranty Disclaimer. Powerex has made a diligent effort to illustrate and describe the Products in its literature, including its Price Book, accurately; however, such illustrations and descriptions are for the sole purpose of identification, and do not express or imply a warranty that the Products are merchantable, or fit for a particular purpose, or that the Products will necessarily conform to the illustrations or descriptions.

Product Suitability. Many jurisdictions have codes and regulations governing sales, construction, installation, and/or use of Products for certain purposes, which may vary from those in neighboring areas. While Powerex attempts to assure that its Products comply with such codes, it cannot guarantee compliance, and cannot be responsible for how the product is installed or used. Before purchase and use of a Product, please review the Product applications, and national and local codes and regulations, and be sure that the Product, installation, and use will comply with them.

Claims. Any non-warranty claims pertaining to the Products must be filed with Powerex within 6 months of the invoice date, or they will not be honored. Prices, discounts, and terms are subject to change without notice or as stipulated in specific Product quotations. Powerex shall not be liable for any delay or failure arising out of acts of the public enemy, fire, flood, or any disaster, labor trouble, riot or disorder, delay in the supply of materials or any other cause, whether similar or dissimilar, beyond the control of Company. All shipments are carefully inspected and counted before leaving the factory. Please inspect carefully any receipt of Products noting any discrepancy or damage on the carrier's freight bill at the time of delivery. Discrepancies or damage which obviously occurred in transit are the carrier's responsibility and related claims should be made promptly directly to the carrier. Returned Products will not be accepted without prior written authorization by Powerex and deductions from invoices for shortage or damage claims will not be allowed. **UNLESS OTHERWISE AGREED TO IN WRITING, THE TERMS AND CONDITIONS CONTAINED IN THIS LIMITED WARRANTY WILL CONTROL IN ANY TRANSACTION WITH POWEREX.** Any different or conflicting terms as may appear on any order form now or later submitted by the buyer will not control. All orders are subject to acceptance by Powerex.