

## Specification

### General

The Powerex medical vacuum system is designed to create a suction system to remove unwanted fluids or gases from hospital/ laboratory working areas. The medical vacuum system package is compliant with the NFPA 99 requirements for Risk Category 1 systems. Each system is completely tested before shipment and

includes:

- Multiple vacuum pumps and associated equipment.
- AMSE air receiver.
- Medical control panel.

Each pump is factory piped to a common intake manifold. Vibration isolation pads are included with the system.

### Claw Vacuum Pump

Each pump shall be a rotary claw type vacuum pump, and shall be direct-driven through a shaft coupling by a C-face, TEFC electric motor.

- Each vacuum pump shall be dry-running, featuring two claw-type, non-contacting rotors and shall not require any sealing fluid in the pumping chamber, assuring virtually maintenance-free operation.
- Each vacuum pump shall include an internal relief valve, and a built-in, anti-suck-back valve mounted at the pump inlet.
- Each pump within the system shall include a check valve, inlet and discharge flex connectors, a 5 micron inlet filter and a pump isolation valve.

### Motor

The motor is continuous duty, C-face, TEFC, suitable for 208-230, or 460V, 3 phase, 60 hertz electrical operation.

### Air Receiver

The system shall include an ASME rated air receiver. The tank shall be equipped with a vacuum gauge, a sight gauge, by-pass valves, and a manual drain.

### Premium NFPA Control Panel

The control system provides automatic lead/lag sequencing and automatic alternation of all pumps in order to equalize the amount of usage among the available vacuum pumps. The Premium NFPA Control panel shall include a gateway server card and all features listed below:

- PLC controller and a color touch screen panel which displays the operating status of the unit.
- Building automation communication gateway with BacNet® protocol and Web server features. Web servers features include email notifications in case the system is in alarm or has achieved one its maintenance intervals and requires service.
- Ethernet port for connection to BacNet® server or direct connection to facility Ethernet for viewing of system operations and status via device IP-address.
- UL508A listed control panel in a NEMA 12 enclosure. The panel door will include: the HMI touch screen, an audible and visual

alarms with an acknowledge button, and an HOA switch for each pump.

- Magnetic starters.
- Vacuum transducer for process control.
- Single point power connection.
- Redundant 120Vac control transformers with fused primary and secondary protection.
- System overload trip, high temperature conditions or maintenance intervals for the pump will result in visual and audible alarms.

### Optional VFD Control Panel

Variable Frequency Drive (VFD) control improves efficiency over a conventional “on/off” demand based system by more closely matching the pump speed to the changing load requirements. All VFD systems come standard with a Premium NFPA Control panel. The VFD and Premium NFPA Control Panel shall include a gateway server card and all features listed below:

- PLC controller and a color touch screen panel which displays the operating status of the unit.
- Building automation communication gateway with BacNet® protocol and Web server features. Web server s features include email notifications in case the system is in alarm or has achieved one its maintenance intervals and requires service.
- Ethernet port for connection to BacNet® server or direct connection to facility Ethernet for viewing of system operations and status via device IP-address.
- UL508A listed control panel in a NEMA 12 enclosure. The panel door will include: the HMI touch screen, an audible and visual alarms with an acknowledge button, VFD start/stop switch and an HOA switch for each pump.
- Magnetic starters.
- Vacuum transducer for process control.
- Single point power connection.
- Redundant 120Vac control transformers with fused primary and secondary protection.
- System overload trip, high temperature conditions or maintenance intervals for the pump will result in visual and audible alarms.

### Available Options

- Oxygen assured pumps - prepared for use in WAGD systems.
- Internal tank lining for corrosion resistance.
- Variable Frequency Drive (VFD) Control Panel – with Premium NFPA controls.

Dimensions					
Model	Dim. A	Dim. B	Dim. C	Inlet	Outlet (x5)
CVPP1505	180"	81"	84"	4"	2"

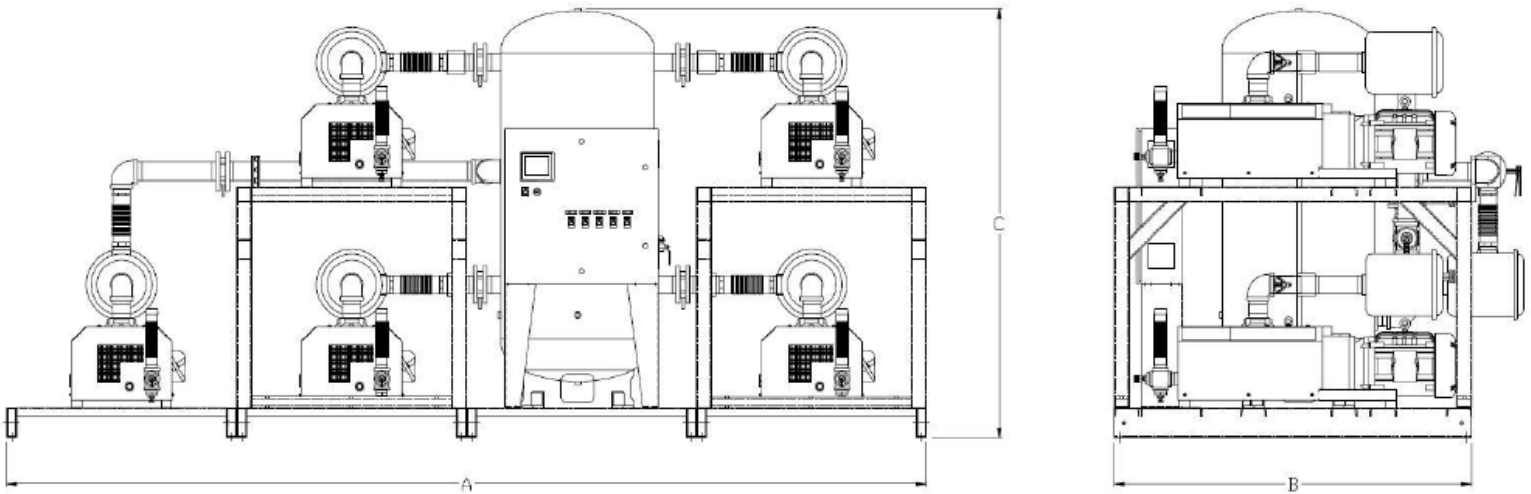
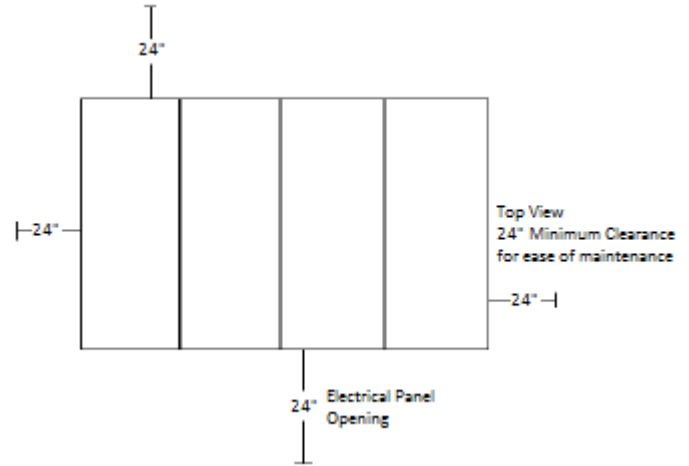

Claw Vacuum Package with Premium Controls										
Model	New HP	SCFM @ 19" Hg each	NFPA System Capacity <sup>(1)</sup>	Tank Size (gal)	BTU/Hr <sup>(2)</sup>	dB(A) Level <sup>(3)</sup>	System F.L.A.			System Weight (lbs)
							208V	230V	460V	
CVPP1505	15 (5)	118	516	200 V	121,380	87	204.5	177.0	89.5	7,885

Notes:

- 1 – System Capacity is shown with one or more pumps in reserve per NFPA 99.
- 2 – BTU/Hr levels are shown with reserve pump(s) on standby.
- 3 – dB(A) levels are shown with one pump in reserve per NFPA 99.
- 4 – 3 Year Limited Warranty.