

Specification

General

The Powerex laboratory vacuum system is designed to create a suction system to remove unwanted fluids or gases from laboratory working areas. The laboratory vacuum system package is compliant with the NFPA 99 requirements for Risk Category 3 laboratory systems. Each system is completely tested before shipment and includes:

- Multiple vacuum pumps and associated equipment.
- AMSE air receiver.
- NEMA 12 multiplex control panel.

Each pump is factory piped to a common intake manifold. Vibration isolation pads are included with the system.

Rotary Vane Vacuum Pump

Each vacuum pump shall be of the rotary vane aircooled design. Each vacuum pump shall be directdriven through a shaft coupling by a TEFC electric motor. Belt drives shall not be permitted. The vacuum pumps shall be mounted on vibration isolators.

- Each vacuum pump shall be air-cooled and have absolutely no water requirements.
- Each pump is equipped with a 5 micron inlet filter for removal of particulates.
- Lubrication shall be provided by an integral, fully recirculating oil supply that is filtered by an automotive-type, spin-on oil filter. Non-recirculating (once-through) or partial re-circulating oil supply systems shall not be permitted. Each vacuum pump is supplied with ISO100 PAO synthetic oil.
- The oil separation systems shall be integral and shall consist of no less than three stages of internally installed oil and smoke eliminators through which the exhaust gas stream must pass. This system shall consist of bulk separation, oil mist elimination, and smoke elimination, and shall be capable of removing 99.9+ percent of all oil and smoke particles from the exhaust gas stream.
- Each vacuum pump shall include a built-in, antisuck-back valve, mounted at the pump inlet, and three sliding vanes.

Each pump is initially filled with full synthetic oil for improved lubrication, longer life, and chemical resistance.

Motor

The motor is continuous duty, C-face, TEFC, suitable for 208-230, or 460V, 3 phase, 60 hertz electrical operation.

Air Receiver

The system shall include an ASME rated air receiver. The tank shall be internally lined and come with a manual drain and sight gauge. Systems with Basic Controls are also equipped with a vacuum gauge. Receiver is plumbed so that system vacuum must pass through the air receiver prior to the pumps to provide additional protection for the pumps.

Premium NFPA Control Panel

The control system provides automatic lead/lag sequencing and automatic alternation of all pumps in order to equalize the amount of usage among the available vacuum pumps. The Premium NFPA Control Panel shall include a gateway server card and all features listed below:

- PLC controller and a 6" color touch screen panel which displays the operating status of the unit.
- Building automation communication gateway with BacNet® protocol and Web server features. Web server features include email notifications in case the system is in alarm or has achieved one its maintenance intervals and requires service.
- Ethernet port for connection to BacNet® server or direct connection to facility Ethernet for viewing of system operations and status via device IP-address.
- UL508A listed control panel in a NEMA 12 enclosure. The panel door will include: the color touch screen, audible and visual alarms with an acknowledge button, and an HOA switch for each pump.
- Magnetic starters.
- Vacuum transducer for process control.
- Single point power connection.
- Redundant 120VAC control transformers with fused primary and secondary protection.
- System overload trip, high temperature conditions, low vacuum or maintenance intervals for the pump will result in visual and audible alarms.

Optional Auto Purge

NOTE: This option is available with our Premium NFPA Control Panel. It is not available on systems with Basic NFPA controls.

Systems with the auto purge feature will include:

- Control and operation of air actuated and/or electric isolation and purge valves.
- 3-position mode switch (Auto-Off-Manual).
- Pump Status (PUMP ON, PUMP READY, PUMP OFF, PUMP PURGING).

Pumps will run through an automatic purge cycle every 24 hours (after alternation phase), to purge any gases from the pump to atmosphere. A 3-position switch is provided to select automatic purge, manual purge, or purge off modes.

NOTE: Pneumatic purge isolation valves require 80 psi compressed air to be field supplied.

Dimensions					
Model	Dim. A	Dim. B	Dim. C	Inlet	Outlet (x2)
LVD0203	38"	86"	68"	1 ½"	1 ½"
LVD0303	38"	85"	68"	2"	1 ½"
LVD0404	38"	93"	72"	2"	1 ½"
LVD0504	44"	97"	72"	3"	2"

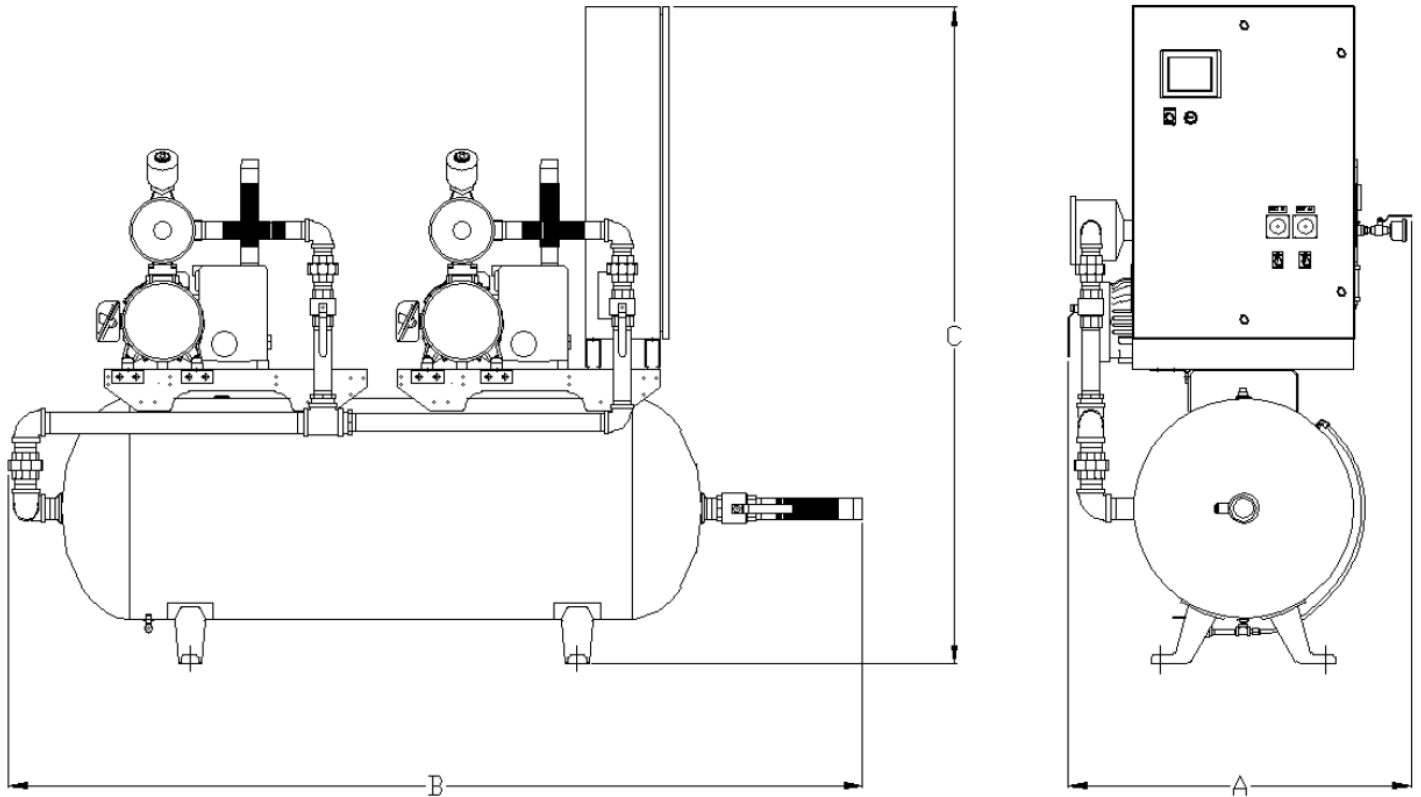
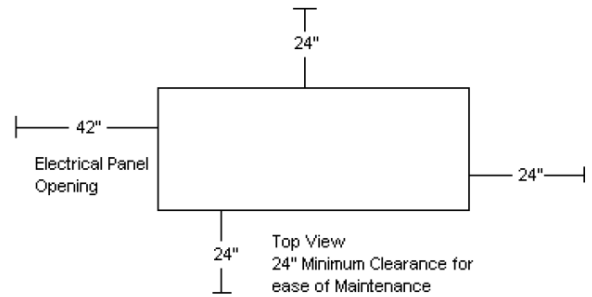

Laboratory Lubricated Vane Vacuum Package									
Model	HP	SCFM @ 19" Hg each	Tank Size (gal)	BTU/Hr ⁽¹⁾	dB(A) Level ⁽¹⁾	System F.L.A. ⁽¹⁾			System Weight (lbs)
						208V	230V	460V	
LVD0203	2 (2)	22	80	8,670	69	13.2	12.8	7.4	850
LVD0303	3 (2)	34	80	13,006	69	18.8	17.6	9.8	900
LVD0404	5 (2)	50	120	21,676	71	29.6	28	15	1,050
LVD0504	5 (2)	74	120	21,676	77	30.6	27.8	14.9	1,000

Notes:

- 1 – SCFM, BTU, dB(A), and FLA values listed are with all pumps running.
- 2 – 3 Year Limited Warranty.