



Installation & Operating Instructions for Genesys2 LL & PL Series Manifolds



Model LL



Model PL

Contents

Features & Benefits	3	Appendix A Glossary of Terms	27
General Instructions	4	Appendix B Technical Specifications	28
Introduction	4	Appendix C Operational Pressure Specifications	29
Installation	5	Appendix D Wiring Diagram	30
Mounting	5	Appendix E Wiring Diagram for Buzzer Kit	31
Plumbing Model LL	6	Warranty	32
Plumbing Model PL	8	Technical Assistance	1-888-769-7979
Electrical	9		
Remote Alarm Wiring Model LL	10, 12		
Remote Alarm Wiring Model PL	11, 12		
Installation – Pigtails & Cylinders	13		
Start Up & Checking Procedures Model LL	15		
Start Up & Checking Procedures Model PL	17		
Emergency Reserve Plumbing & Wiring Models LL & PL	18		
Cylinder Replacement & Handling	19		
Line Delivery Pressure Adjustment	19		
Programming Adjustments	20		
General Maintenance	21		
Table of Error Codes	21		
Table of Alarm Codes	22		
Replacement Parts	23		
Trouble Shooting Guide	25		

Features & Benefits

- **Fully automatic changeover**
 - No valves or levers to reset after each changeover.
- **Compatible with Powerex T-Net medical gas monitoring system**
 - Saves time and improves safety.
- **Economizer software**
 - Ensures empty portable bulk vessels will not be put back into reserve and the entire liquid contents of portable bulk vessels is used.
- **Economizer hardware**
 - Allows head pressure from secondary portable bulk vessels to be used – instead of vented.
- **Field upgradeable design**
 - Kits allow unit to be changed from - i.e. cylinders to portable bulk or from standard flow to high flow or from lower delivery pressure to higher delivery pressure.
- **Circuit board triggers all required NFPA 99 alarms**
 - Simplifying wiring and reducing cost.
- **Unit includes hi/low line pressure transducer**
 - Eliminating need to purchase hi/low pressure switch improving alarm accuracy and improving safety (manifold will automatically alarm if a transducer goes bad).
- **Easy to service layout/design**
- **Microprocessor-based control panel**
 - Incorporates LED's and illuminated text display readable even in poor lighting conditions.
- **Electronic monitoring of circuits**
 - Up to 19 error, alarm or information messages displayed for ease of maintenance.
- **Accurate, long life pressure transducers for monitoring of line pressure and bank pressures**
- **Analog gauges also provided for use in event of power failure**
- **Pressures may be displayed in PSIG / kPa / BAR**
- **Built in DISS gas specific emergency feed ports**
- **Built in emergency reserve bank ports**
- **Input power 120 VAC, 50 to 60 Hz**
(120 – 240 VAC, 50 to 60 Hz on all models without heaters)
- **Dual line pressure regulators on NFPA 99 models**
- **Gas specific header bar with integral check valves and cylinder pigtail assemblies**
- **Variety of header configurations available to meet the available space requirements of your installation**
- **Available in weatherproof cabinet for outdoor installation**

Introduction

Powerex manifolds are cleaned for use with oxygen. Each system is tested for changeover, triggering of alarms and leakage. Each unit is designed and prepared for the indicated gas service. Powerex manifolds are built in accordance with the National Fire Protection Association and Compressed Gas Association guidelines.

Warranty

All Powerex manifolds are warranted against defects in material and workmanship for the period of one year from date of purchase. All circuit boards are warranted against defects in material and workmanship for the period of three years from date of purchase.

General Instructions/Location & Shelter

Manifolds should be installed in accordance with guidelines stated by the National Fire Protection Association, the Compressed Gas Association, OSHA, and all applicable local codes. Central supply systems and cylinders should not be placed in a location where the temperature will exceed 125°F (51.6°C) or fall below -20°F (-29°C). A manifold placed in an open location should be protected against weather conditions. During winter, protect the manifold from ice and snow. In summer, shade the manifold and cylinders from continuous exposure to direct sunlight. The flow capacity of nitrous oxide and carbon dioxide manifolds depend upon ambient temperature and the number of cylinders on line. Contact your gas supplier to determine the vaporization rate of Carbon Dioxide and Nitrous Oxide cylinders for the ambient temperature climate at the installation site.

Leave all protective covers in place until their removal is required for installation. This precaution will keep moisture and debris from the piping interior.

Caution

Failure to follow the following instructions can result in personal injury or property damage:

- Never permit oil, grease, or other combustible materials to come in contact with cylinders, manifold, and connections. Oil and grease may react with explosive force when ignited while in contact with some gases – particularly oxygen and nitrous oxide.
- Cylinder and master valves should always be opened very slowly. Heat of recompression may ignite combustible materials creating an explosive force.
- Pigtails should never be kinked, twisted, or bent into a radius smaller than 3 inches. Mistreatment may cause the pigtail to burst.
- Do not apply heat. Oil and grease may react with explosive force when ignited while in contact with some gases – particularly oxygen and nitrous oxide.
- Cylinders should always be secured with racks, chains, or straps. Unrestrained cylinders may fall over and damage or break off the cylinder valve which may propel the cylinder from its current position.
- Oxygen manifolds and cylinders should be grounded. Static discharges and lightning may ignite materials in an oxygen atmosphere, creating a fire or explosive force.
- Welding should not be performed near nitrous oxide piping. Excessive heat may cause the gas to dissociate, creating an explosive force.
- Remove all protective caps prior to assembly. The protective cap may ignite due to heat of recompression in an oxygen system.

Control Cabinet Installation

- Determine and mark the vertical center line for installation of the manifold control cabinet.
- If you wish to place cylinders under the manifold cabinet, measure from the floor to a point 79" in height above the finished floor of this vertical line. Using a level, mark a horizontal line at this point extending approximately 7" to the left and 7" to the right of center. This line indicates the location for the bottom two mounting bolts of the Z mounting bracket. Mounting the Z bracket @ 79" aff* will result in the bottom of the manifold cabinet being 60" aff – allowing cylinders to be placed under the manifold cabinet. If you do not wish to place cylinders under the manifold cabinet, measure from the floor to a point 58 ½" aff and follow the same steps above.
- Mount the Z mounting bracket to the wall using fasteners suitable for the type of wall construction.
- Temporarily hang the manifold cabinet on the Z bracket just installed, mating it with the Z bracket on the back of the manifold cabinet. Mark the locations of the two lower cabinet mounting holes on the wall.
- Remove the manifold cabinet and install female portion of suitable fasteners for lower cabinet mounting holes.
- Re-hang the manifold cabinet and install suitable fasteners in the lower cabinet mounting holes.

* aff = above finished floor

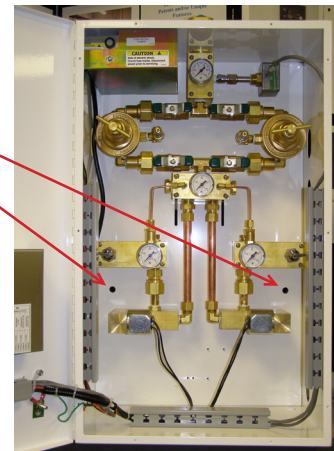
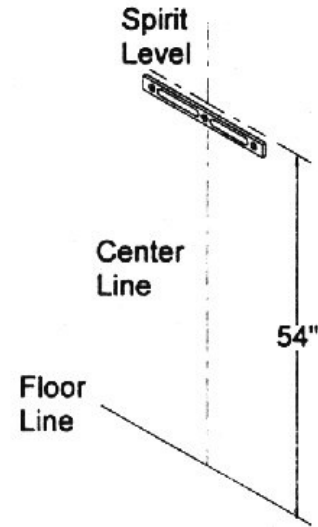

Header Installation

- Attach the headers to the union on each side of the manifold control cabinet. Using a level, mark the placement of mounting brackets while keeping the header on a horizontal plane.
- Remove the U-bolt assemblies from the header mounting brackets. Position the brackets so that the top of the bracket is aligned with the bottom of the headers and is centered between the cylinder connections. The end bracket should be placed as close to the last cylinder as possible to provide the most support and stability.

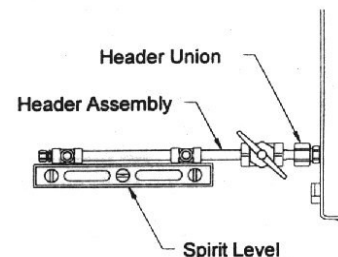

- Mark the mounting hole and install fasteners suitable for type of wall construction.
- Fit the U-bolt over the header piping and tighten the two mounting nuts.

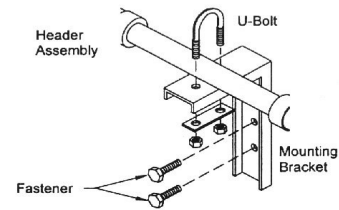

Plumbing – Model LL

- The outlet of the manifold is located at the top center of the unit as shown here. The outlet connection is 1/2 NPT female. A source valve 1/2 M NPT x 3/4 tube extension has been provided with all NFPA 99 compliant models (part # 48-0023) and should be installed in the manifold outlet. It may be necessary to install a 1/2 NPT 90° street elbow (part # 17-0300 sold separately) to meet the confines of the installation site.
- Source valve part # 48-0023 (should be installed on the manifold cabinet prior to mounting on the wall).



Recommended Vent Line and Emergency Reserve Plumbing

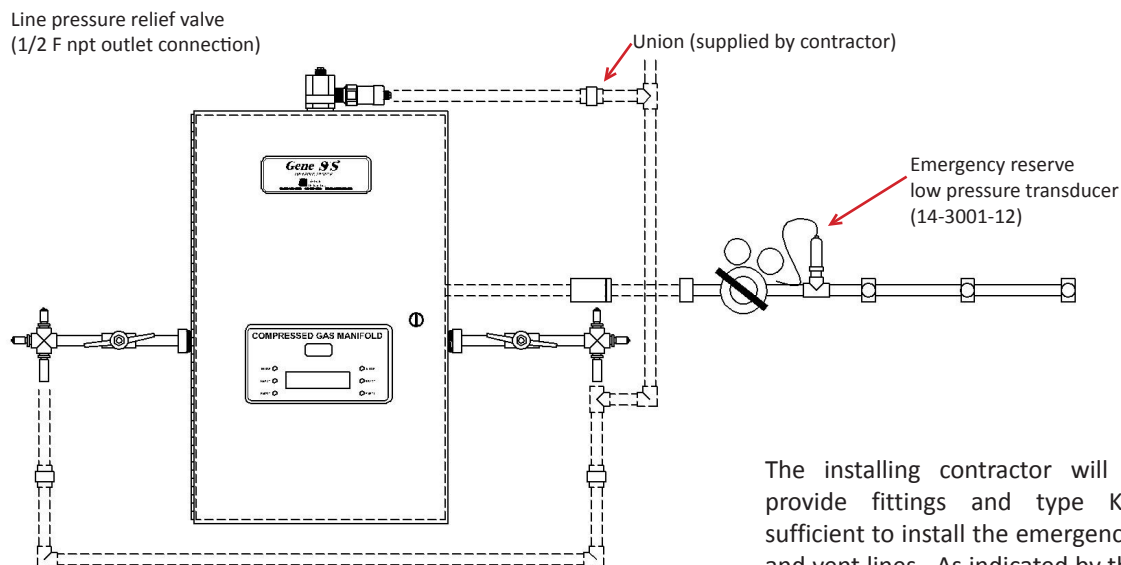

The installing contractor will need to provide fittings and type K copper sufficient to install the emergency reserve and vent lines. As indicated by the dotted lines in this drawing.

Plumbing – Model LL

- In addition to connecting the left & right primary and secondary portable bulk vessel supply banks, the LL models must also have a high pressure reserve bank of cylinders connected to the cabinet to be in compliance with NFPA 99 guidelines.
- The model LL has one ½ NPT female line pressure relief valve connection and two 3/8 NPT female intermediate pressure relief valve connections. (This installation is typical – with the two intermediate relief vent lines and the line pressure relief vent line brought together as a common vent line that exits the facility either thru an exterior wall or the roof). See bottom of page 6.
- The intermediate block has a ½ npt plug which may be removed to allow the emergency reserve to be piped in through either the left or the right side of the cabinet. Slots have been provided on both the left and right sides of the control cabinet to allow for the high pressure reserve piping.
- Emergency reserve in use pressure transducer (14-3002) – installed in factory when ordered with LL manifold.
- CV-050F check valve (must be installed between the manifold cabinet and downstream of the high pressure reserve regulator).

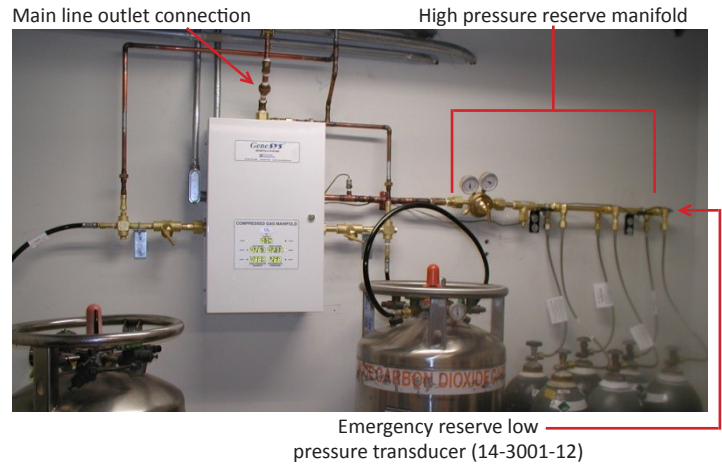

Emergency reserve low pressure transducer (14-3001-12) installed into port on RWP reserve manifold by plumber.

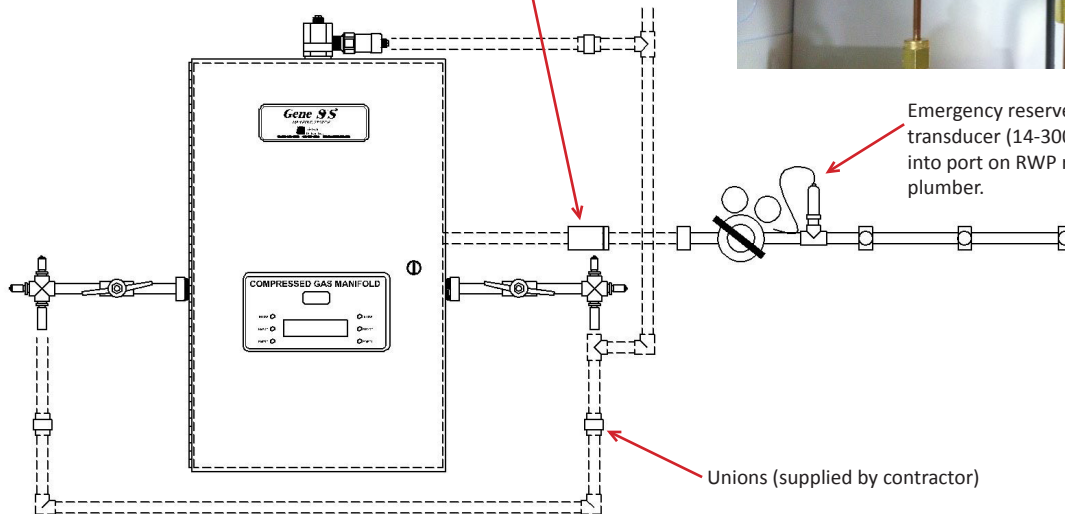

Plumbing – Model PL

- In addition to connecting the left primary portable bulk vessel supply bank, the PL models must also have a high pressure reserve bank of cylinders and a high pressure emergency reserve bank of cylinders connected to the cabinet to be in compliance with NFPA 99 guidelines.
- A transducer (part # 14-3001-5) must be installed (by installer) into the port provided in the right / secondary manifold header.
- The model PL has one ½ NPT female line pressure relief valve connection and one ¾ NPT female intermediate pressure relief valve connections. (This installation is typical – with the intermediate relief vent line and the line pressure relief vent line brought together as a common vent line that exits the facility either thru an exterior wall or the roof). (See drawing at bottom of page).
- The intermediate block has a ½ npt plug which may be removed to allow the emergency reserve to be piped in through either the left or the right side of the cabinet. Slots have been provided on both the left and right sides of the control cabinet to allow for the high pressure reserve piping.
- Emergency reserve in use pressure transducer (14-3002) – installed in factory when ordered with PL manifold.
- CV-050F check valve (must be installed between the manifold cabinet and downstream of the high pressure reserve regulator).

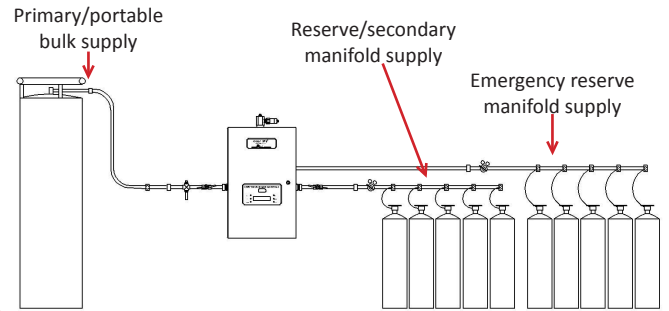

Emergency reserve low pressure transducer (14-3001-12) installed into port on RWP reserve manifold by plumber.

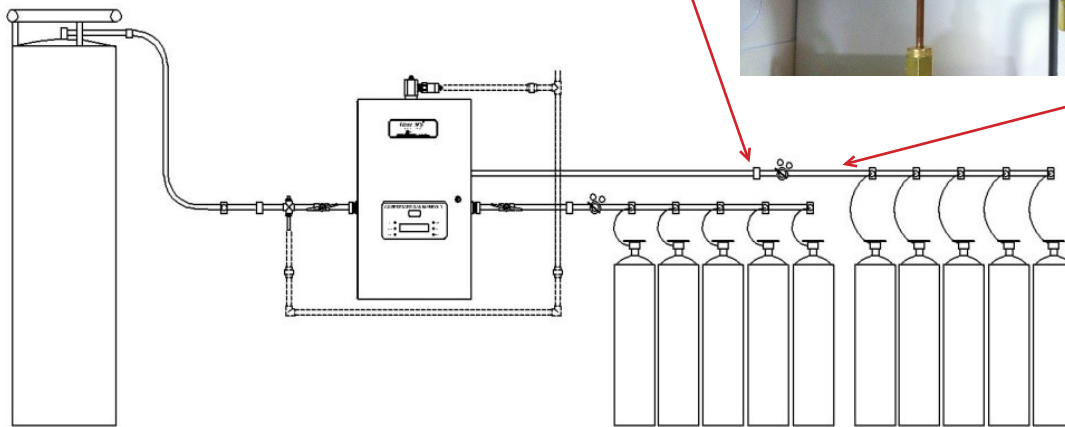

The installing contractor will need to provide fittings and type K copper sufficient to install the emergency reserve and vent lines. As indicated by the dotted lines in this drawing.

Electrical

- Use one of the two ½” conduit knock-outs provided located nearest to the top left corner of the cabinet to route conduit to supply 120 VAC to the power supply.

Note: Separate conduit should be used for low voltage wires (use knock outs provided on the left side of the box).

120-240 / 1 / 50 – 60 Hz may be used with all units. If the unit has heaters, the heaters only may be wired to 120/1/50-60. An additional transformer (sold separately part # 35-3004) is required to connect heaters to 240 VAC.

- Remove the power supply cover by loosening the screw located at the top of the cover and then sliding the power supply cover to the right until the screw is in the center of the tear-drop shaped cut out. Next, pull the cover forward until it clears the screw head and the fuse. **Note:** the bottom of the cover inserts into a slot in the back plate. Allow the cover to rest on the dual line regulator assembly plumbing just below the power supply.
- Route wires of proper gauge (per local building code requirement) through the power supply conduit, thru the grommet on the power supply bracket and into the terminal strip.
- Connect the 120 VAC facility emergency power source electrical wiring to the terminal strip provided on the front of the power supply mounting bracket (per photos right). (N = neutral, L = load, FG = field ground).
Note: The ground must be a solid earth ground with little or no resistance. A “noisy” earth ground may affect the digital display of the manifold.

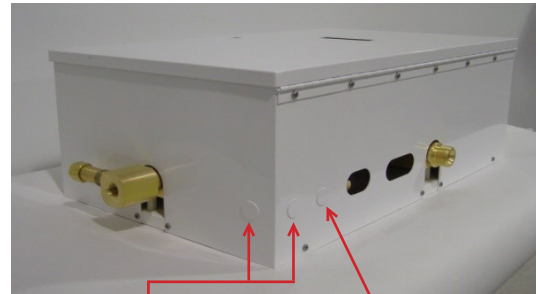

Conduit knockouts for 120 VAC Conduit knockout for low voltage alarm signals

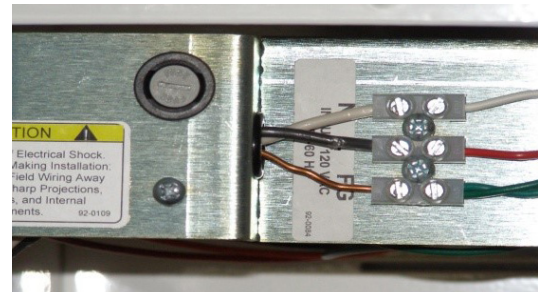
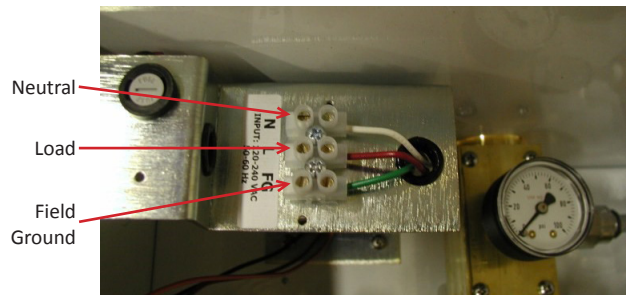

Wiring – Remote Alarms – Model LL

Caution: Never connect or disconnect any electrical components with the power on. This may result in damage to components and is not covered under warranty.

- Wires for remote alarms should be brought into the cabinet thru conduit or shielded cables (check local code requirements) thru the knockouts on the left side of the cabinet shown here.

Note: Separate conduit should be used for high voltage wires – never run low voltage wires in the same conduit as high voltage wires.

- If you are installing a model LL with emergency reserve there are five alarm signals required per NFPA 99:
 - High Line Pressure
 - Low Line Pressure
 - Secondary in Use
 - Emergency Reserve in Use
 - Emergency Reserve Low

The circuit board will trigger all five of these alarms (no pressure switches are required). The line pressure transducer must be installed outside of the cabinet – downstream of the source or main line valve with the cable being wired to the manifold circuit board to comply with NFPA 99. In this photo the line pressure transducer has been assembled into our PSM-XX assembly and connected to the gauge port on the downstream (patient side) of the source valve and wired to the manifold circuit board.

- The line pressure transducer may also be mounted inside the cabinet (as shown here). In this arrangement, a high/low pressure switch (sold separately) will be required to meet the NFPA 99 recommendations.

Note: The hi/low pressure switch (supplied separately) would be wired directly to the master alarm panels – not to the manifold circuit board.

- Remote alarm wires are connected to the circuit board at the terminal gate labeled MB5. Signal wires and Common wires for; Low Line Pressure, High Line Pressure, Secondary in Use, Emergency Reserve in Use and Emergency Reserve Low should be connected to the terminals as indicated.

Note: All remote alarm terminals are normally closed when the gas pressure is in the normal range. The hi/low set points pre-programmed into the manifold circuit board logic chip are as per the charts on page 31. If desired, the high and low line pressure alarm set points may be adjusted by following the instructions on page 20.

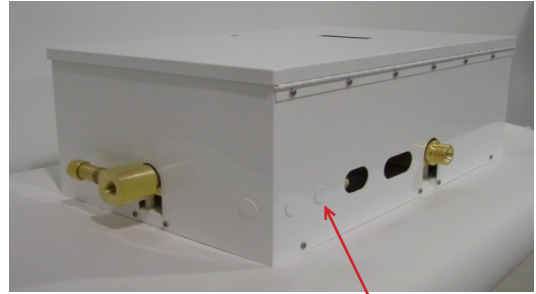

Knockout for low voltage remote alarm wiring

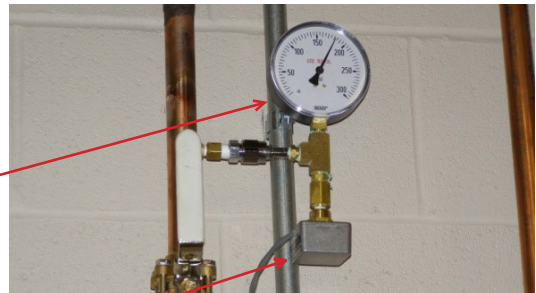

Line pressure transducer

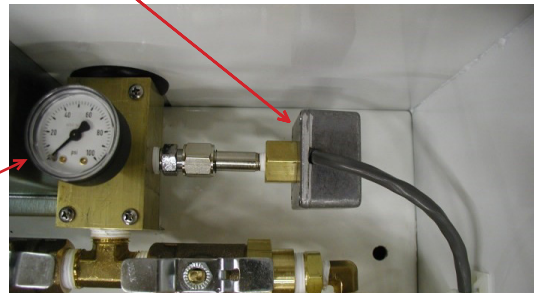

MB-4				MB-5							
POWER SUPPLY INPUT				ALARM SIGNAL OUTPUTS							
ORANGE (+)	RED (+)	BLACK (-) COMMON	GREEN/EARTH GROUND	SOLENOID RIGHT BANK	SOLENOID LEFT BANK	RIGHT BANK/ SECONDARY LOW	LOW LINE PRESSURE	HIGH LINE PRESSURE	SECONDARY IN USE	EMERGENCY RESERVE IN USE	EMERGENCY RESERVE LOW
24 VDC	5 VDC						NORMALLY CLOSED	NORMALLY CLOSED	NORMALLY CLOSED	NORMALLY CLOSED	NORMALLY CLOSED
							COMMON	COMMON	COMMON	COMMON	COMMON

Wiring – Remote Alarms – Model PL

Caution: Never connect or disconnect any electrical components with the power on. This may result in damage to components and is not covered under warranty.

- Wires for remote alarms should be brought into the cabinet thru conduit or shielded cables (check local code requirements) thru the knockouts on the left side of the cabinet shown here.

Note: Separate conduit should be used for high voltage wires – never run low voltage wires in the same conduit as high voltage wires.

- If you are installing a model LL with emergency reserve there are five alarm signals required per NFPA 99:
 - High Line Pressure
 - Low Line Pressure
 - Secondary in Use
 - Emergency Reserve in Use
 - Emergency Reserve Low

The circuit board will trigger all six of these alarms (no pressure switches are required). The line pressure transducer must be installed outside of the cabinet – downstream of the source or main line valve with the cable being wired to the manifold circuit board to comply with NFPA 99. In this photo the line pressure transducer has been assembled into our PSM-XX assembly and connected to the gauge port on the downstream (patient side) of the source valve and wired to the manifold circuit board.

- The line pressure transducer may also be mounted inside the cabinet (as shown here). In this arrangement, a high/low pressure switch (sold separately) will be required to meet the NFPA 99 recommendations.

Note: The high/low pressure switch would be wired directly to the master alarm panels – not to the manifold circuit board.

- Remote alarm wires are connected to the circuit board at the terminal gate labeled MB5 and MB4. Signal wires and Common wires for; Low Line Pressure, High Line Pressure, Secondary in Use, Emergency Reserve in Use and Emergency Reserve Low should be connected to the terminals as indicated on MB5. The Signal & Common wires for Secondary (right bank) Low should be connected to the terminals as indicated on MB4.

Note: All remote alarm terminals are normally closed when the gas pressure is in the normal range. The hi/low set points pre-programmed into the manifold circuit board logic chip are as per the charts on page 31. If desired, the high and low line pressure alarm set points may be adjusted by following the instructions on page 20.

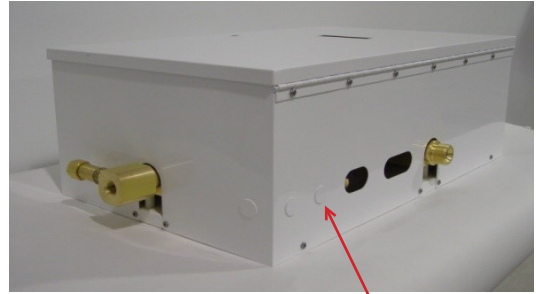

Knockout for low voltage remote alarm wiring

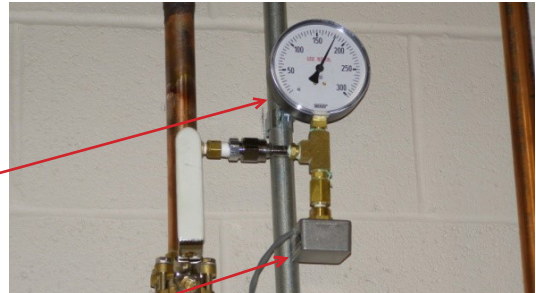

Line pressure transducer

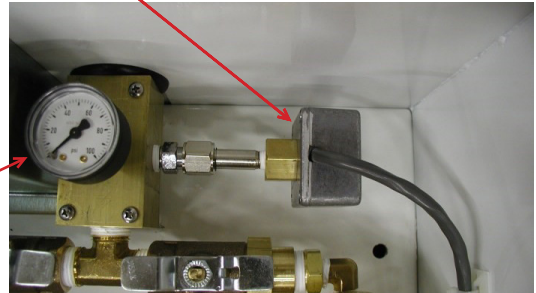

MB-4				MB-5																			
POWER SUPPLY INPUT				ALARM SIGNAL OUTPUTS																			
ORANGE (+)	24 VDC	RED (+)	5 VDC	BLACK (-)	COMMON	GREEN/EARTH	GROUND	BLACK	SOLENOID RIGHT BANK	BLACK	SOLENOID LEFT BANK	BLACK	RIGHT BANK/ SECONDARY LOW	NORMALLY CLOSED	COMMON	NORMALLY CLOSED	COMMON	NORMALLY CLOSED	COMMON	NORMALLY CLOSED	COMMON	NORMALLY CLOSED	COMMON

Wiring – Remote Alarms – Model PL

Caution: Never connect or disconnect any electrical components with the power on. This may result in damage to components and is not covered under warranty.

- **BOTH MODELS LL & PL** – The 14-3001-12 emergency reserve low transducer must be wired to the manifold circuit board at the MB-3 connection points labeled “High Pressure Emergency Reserve Pressure Sensor”.
- **MODEL PL ONLY** – The 14-3001-5 Secondary (right bank) Low transducer must be wired to the manifold circuit board at the MB-2 connection points labeled Right Bank Pressure Sensor.

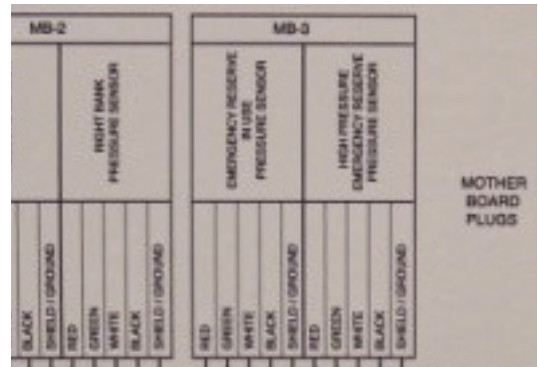

14-3001-12 wiring location

14-3001-12 wiring location

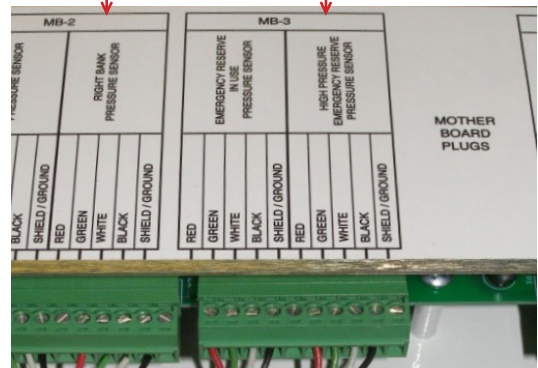

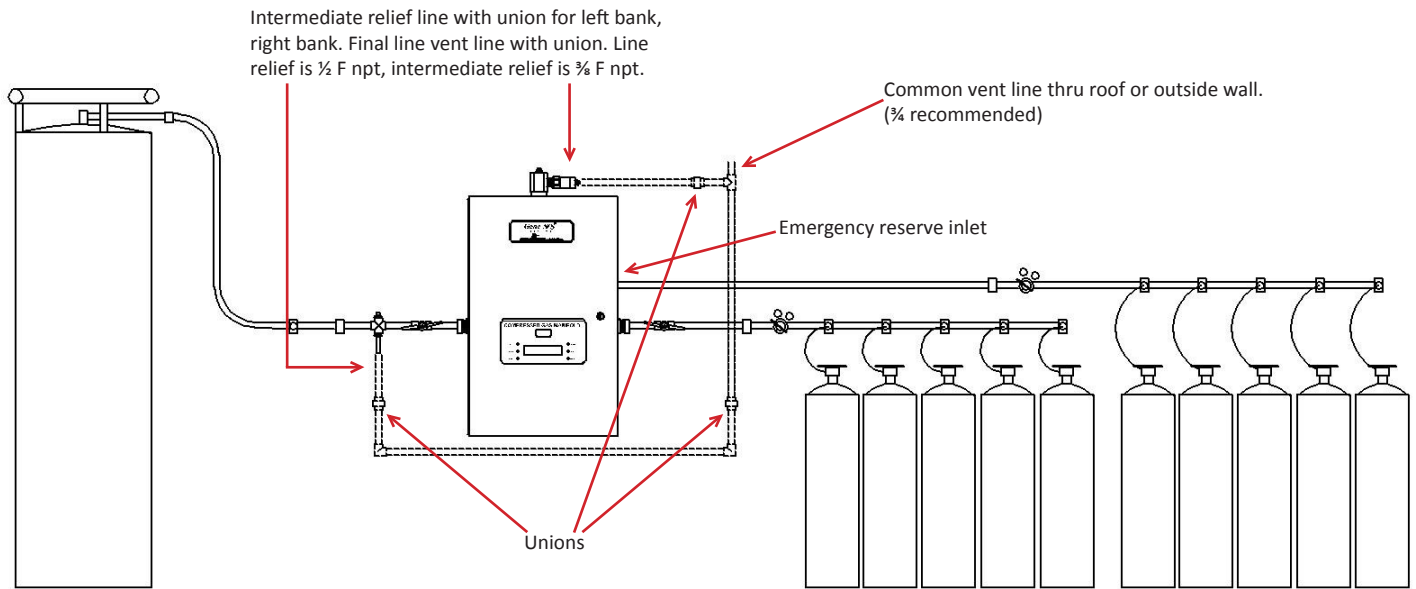

Installing Pigtails & Attaching Cylinders

- This drawing above shows a completed installation. Note the copper vent tubing and tubing between the emergence reserve manifold and control cabinet are installed and furnished by the installer. The unions part #'s are 17-0169 for the line relief and 17-0271 for the intermediate vent relief (two required for model LL if installed indoors).
- The check valve outlet fittings on the manifold header bars are CGA (Compressed Gas Association) gas specific threads. Each of these fittings has an integral check valve. Make sure the 3 digit CGA number stamped on the outer perimeter of these fittings matches the CGA number stamped on the mating CGA fittings on the pigtails. Attach the pigtails to the check valve outlet fittings on the manifold header bars.
- Connect the other end of the pigtail to the "Use" valve mating fitting on the portable bulk vessel. Open the use valve (turn counter-clockwise to open). The pressure building valve or regulator should be turned on or opened for all vessels connected to the manifold (both service and reserve banks). Allow approximately 1 hour for the portable bulk vessel(s) to build pressure.
- Check all cylinder and pigtail connections for leaks using an oxygen safe leak test solution (any bubbles forming around connections indicate leakage).
- Verify that the pressure being supplied to the manifold cabinet exceeds the minimum inlet pressure requirements per the table on page 31.

Ports for two pigtails

Intermediate pressure relief valve x 3/8 F npt

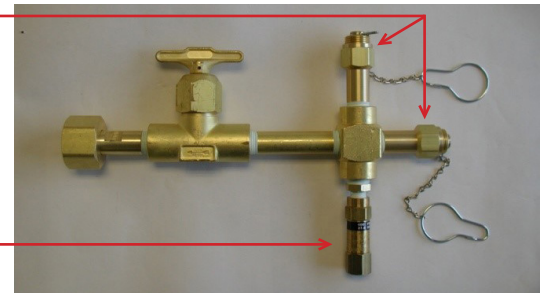

- The check valve outlet fittings on the manifold header bars are CGA (Compressed Gas Association) gas specific threads. Each of these fittings has an integral check valve. Make sure the 3 digit CGA number stamped on the outer perimeter of these fittings matches the CGA number stamped on the mating CGA fittings on the pigtails.
- Connect the pigtails to the check valve outlets on the manifold headers.
- Check the master valves to be certain they are open (turn counter-clockwise to open). (Note: the master valve should always be left open. It is to be used only in the event of an emergency).
- SLOWLY open all cylinder valves until fully open (turn counter-clockwise to open). Check all cylinder and pigtail connections for leaks using an oxygen safe leak test solution (any bubbles forming around connections indicate leakage).

Note: The manifold has been tested for leaks at the factory, but the installer **MUST** check for leaks at all connections made during installation.

Check valve outlet fittings

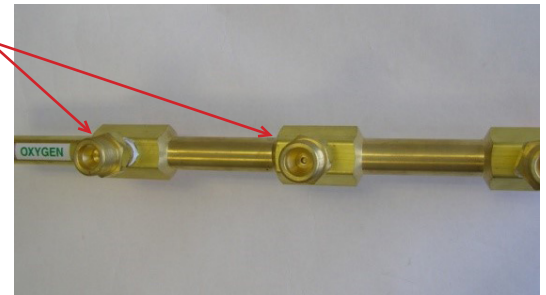

Attach pigtails to header check valve outlets using 1 1/4" open end wrench

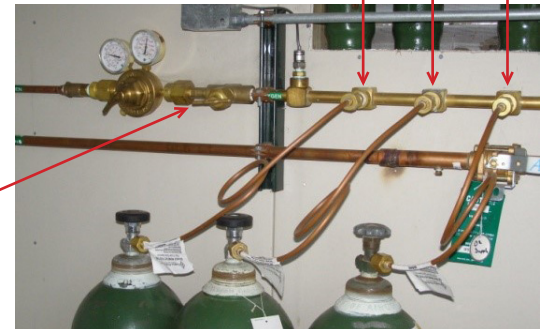

Master valve



Start Up & Checking Procedures – Model LL

The manifold is pre-programmed (per page 31) and tested before it is shipped. You may, however, wish to modify some of the programming (see page 20). The unit has been designed to allow some programming to be simply and safely altered in the field.

- Start with all cylinders turned off and with zero pressure supplied to the manifold cabinet. To conduct the initial start-up testing of the manifold, it is simpler and faster if the circuit board is switched from the standard 'cycling view' (this is the mode in which it is shipped) to the 'global view'. To do this, the cover must be removed from the circuit board and the top #1 dip switch must be switched from the RUN mode to the PROGRAM mode. (Note: local alarms are not displayed when in the global view mode).
- Turn on the 120 VAC to the unit. For both models LL & PL with Emergency Reserve headers utilizing the 14-3001-12, 14-3002 and 14-3001-5 (PL only) transducers, the display should illuminate showing all zeros for the Line Pressure (LIN), Left Bank Pressure (LEFT) and Right Bank Pressure (RIGHT). The intermediate (INT) and emergency reserve (EMER). (Note: If the LL or PL has been installed without an Emergency Reserve or with an Emergency Reserve utilizing pressure switches in place of transducers, the INT (intermediate) and EMER (emergency reserve) can both be made to read zeros if a 35-3013 emergency reserve jumper kit is installed. Both the left and right bank Green (In Use) and Yellow LED's (Ready) should be extinguished and the Red (Empty) LED's should be illuminated.
- Verify that the left vessel has 130 psig or higher by observing the pressure gauge on the vessel. SLOWLY open one cylinder valve on the left bank. The left bank pressure gauge (inside the cabinet) and the text display (on the outside of the cabinet) should show the full pressure of the cylinder. The Red (Depleted) LED for the left bank should have extinguished leaving only the Green (In Use) LED illuminated.
- Verify that the right vessel has 130 psig or higher by observing the pressure gauge on the vessel. SLOWLY open one cylinder valve on the right bank. The right bank pressure gauge (inside the cabinet) and the digital display (on the outside of the cabinet) should show the full pressure of the cylinder. The Red (Depleted) LED for the right bank should have been extinguished and the Yellow (Ready) LED should have illuminated.

Program control buttons

Dip switch #1 Run/Program

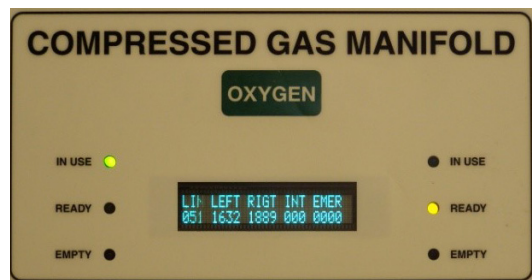
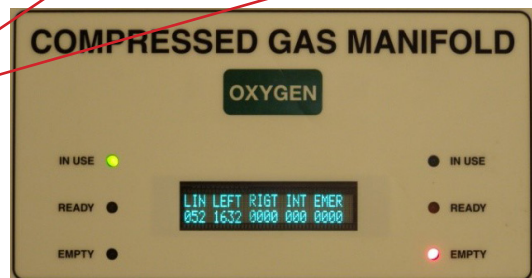
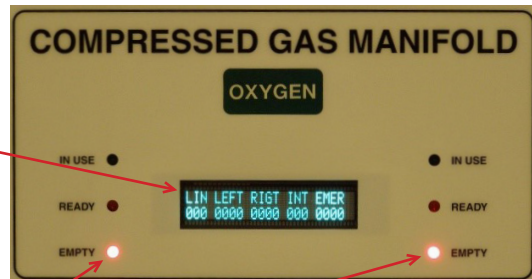
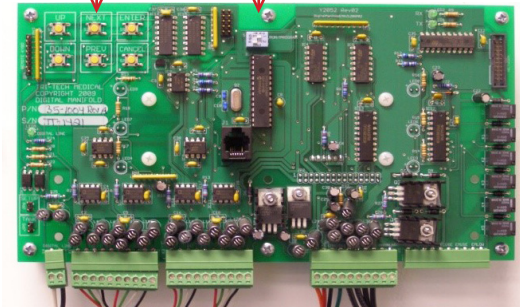

- Turn off all open left bank cylinder valves. Create a slight flow of gas in the delivery pipeline system. DISS demand valves have been provided on the line regulators. Mating DISS fittings may be used to create a flow of gas within the manifold cabinet. The left bank pressure text display and pressure gauge should fall and the control automatically switches over to the right bank. Delivery pressure remains constant. The left bank Red (Empty) LED will illuminate. The secondary supply in use alarm should activate on the master alarm(s).
- SLOWLY reopen the cylinders on the left bank. The left bank pressure gauge and digital display should return to full pressure. The left bank yellow (Ready) LED will illuminate simultaneously the left bank red (Empty) will extinguish. All remote secondary supply in use alarms will be canceled.
- Repeat steps 5 & 6 to simulate an empty right bank.
- The model LL, will also display pressures for the intermediate area (INT) and the emergency reserve (EMER) and trigger the master alarm signal for “Emergency Reserve in Use” and “Emergency Reserve Low”. To properly adjust the emergency reserve regulator the primary and secondary banks must both be shut off and the cabinet pressure drained. SLOWLY open one cylinder on the emergency reserve bank and observe the EMER pressure display and check to make sure it agrees with the gauge on the emergency reserve regulator. Adjust the delivery pressure from the emergency reserve regulator following the table on page 31 (if this is a 50 psig line pressure application this regulator should be set to 65 psig). When testing the Emergency Reserve in Use and Emergency Reserve Low master alarms please note – there is a 15 second delay designed into the manifold logic. The Emergency Reserve in Use alarm will be triggered when the INT pressure falls below 75 psig (50 psig line pressure application) for more than 15 seconds. The Emergency Reserve Low alarm will be triggered when the EMER pressure falls below 1200 psig for more than 15 seconds. Test the Emergency Reserve in Use alarm by first pressurizing both the primary & secondary and the emergency reserve banks, set Dip switch #1 to the RUN/PROGRAM position and close the valves on both the primary & secondary bank vessels, establish a gas flow thru the manifold. After the primary then secondary banks deplete to empty, and the intermediate pressure falls below 75 psig (50 psi line pressure application models) the Emergency Reserve in Use alarm should be triggered after a 15 second delay.
- After you are satisfied that the manifold is functioning properly and that all master alarm signals are being triggered properly. The manifold circuit board should be returned to the ‘cycling view’ mode. This is achieved by moving the dip switch from the PROGRAM to the RUN position.

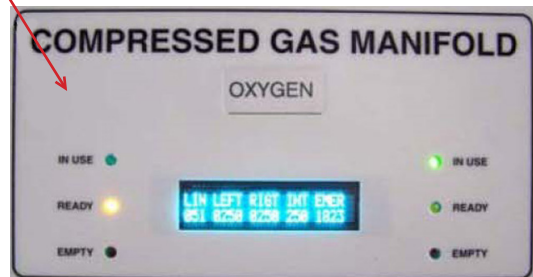
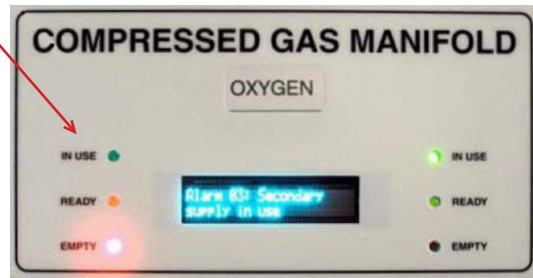
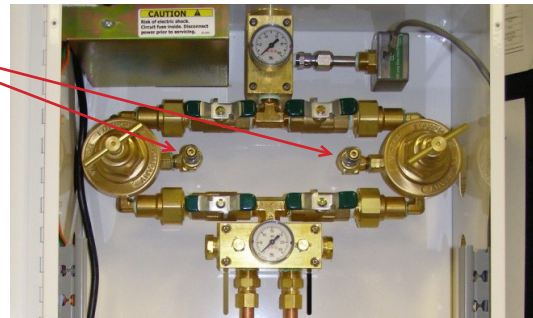

Dip switch #1 set to Run/Program

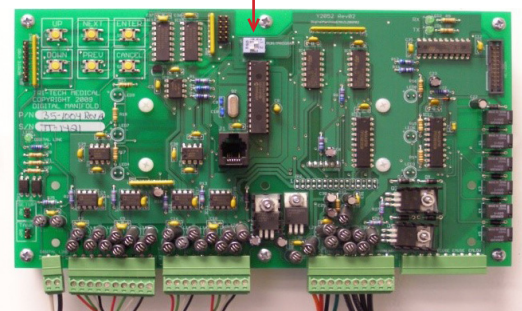

Start Up & Checking Procedures – Model PL

- Turn off all open left bank vessel valves. Create a slight flow of gas in the delivery pipeline system. DISS demand valves have been provided on the line regulators. Mating DISS fittings may be used to create a flow of gas within the manifold cabinet. The left bank pressure text display and pressure gauge should fall and the control automatically switches over to the right bank. Delivery pressure remains constant. The left bank Red (Empty) LED will illuminate. The secondary supply in use alarm should activate on the master alarm(s).
- With the left bank in a red (Empty) condition and the right bank in a green (In Use) condition, create a slight gas flow and close all of the right bank cylinder valves. When the right bank pressure drops below 1,200 psig stop the gas flow. After approximately 15 seconds, the right bank low alarm will be triggered.
- SLOWLY reopen the vessel(s) on the left bank. The left bank pressure gauge and digital display should return to full pressure. The left bank green (In Use) LED will illuminate simultaneously the left bank red (Empty) will extinguish. All remote secondary supply in use alarms will be canceled.
- The unit will also display pressures for the intermediate area (INT) and the emergency reserve (EMER) and trigger the master alarm signal for “Emergency Reserve in Use” and “Emergency Reserve Low”. To properly adjust the emergency reserve regulator the primary and secondary banks must both be shut off and the cabinet pressure drained. SLOWLY open one cylinder on the emergency reserve bank and observe the EMER pressure display and check to make sure it agrees with the gauge on the emergency reserve regulator. With a slight flow of gas, adjust the delivery pressure from the emergency reserve regulator following the table on page 31 (if this is a 50 psig line pressure application this regulator should be set to 65 psig). When testing the Emergency Reserve in Use and Emergency Reserve Low master alarms please note – there is a 15 second delay designed into the manifold logic. The Emergency Reserve in Use alarm will be triggered when the INT pressure falls below 75 psig (50 psig line pressure applications) for more than 15 seconds. The Emergency Reserve Low alarm will be triggered when the EMER pressure falls below 1200 psig for more than 15 seconds. Test the Emergency Reserve in Use alarm by first pressurizing both the primary & secondary and the emergency reserve banks, set Dip switch #1 RUN/PROGRAM position and close the valves on both the primary & secondary bank vessels, establish a gas flow thru the manifold. After the primary then secondary banks deplete to empty, and the intermediate pressure falls below 75 psig (50 psi line pressure application models) the Emergency Reserve in Use alarm should be triggered after a 15 second delay.
- After you are satisfied that the manifold is functioning properly and that all master alarm signals are being triggered properly. The manifold circuit board should be returned to the ‘cycling view’ mode. This is achieved by moving the dip switch from the PROGRAM to the RUN position.

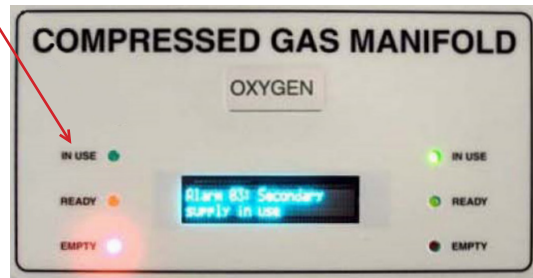
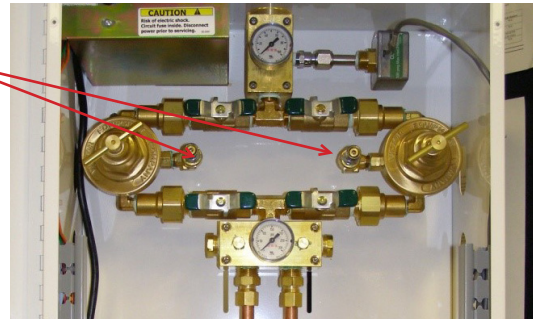

Dip switch #1 set to Run/Program

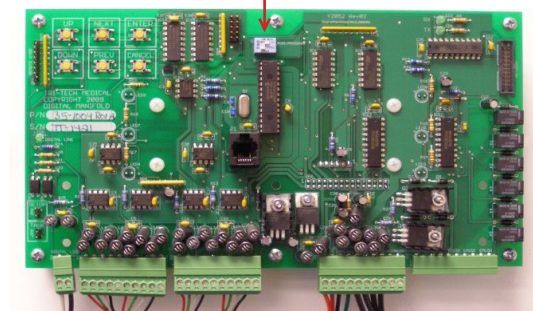

Emergency Reserve Plumbing and Wiring

The manifold includes digital displays for the emergency reserve bank pressure and the intermediate area pressure. (Refer to appendix E – page 31).

Remote master alarms will be triggered by the manifold for the required NFPA 99 alarms;

- High line pressure,
- Low line pressure,
- Secondary in use,
- Emergency reserve in use and
- Emergency reserve low and
- Right bank (secondary) low (on PL units only)

Refer to the appendix E on page 31 for information on setting the delivery (outlet) pressure of the emergency reserve regulator and pre-programmed emergency reserve in use and emergency reserve low alarm set points.

The emergency reserve low bank pressure transducer (part # PX-14-3001-12) should be installed on the extra port on the RWP series manifold. This port is located prior (upstream) to the master valve and the regulator.

Note: if the PX-14-3001-12 and PX-14-3002 transducers are not used (and pressure switches are used instead or not used at all because a reserve manifold is not being used) the “Reserve Alarms” programming option (see page 20) must be disabled and the 35-3013 high pressure reserve jumper kit must be installed or else error codes will be displayed by the circuit board.

The emergency reserve in use pressure transducer (part # PX-14-3002) will be pre-installed on the intermediate block at the factory (when ordered as a set).

Both the emergency reserve low bank pressure transducer and the emergency reserve in use transducer must be wired to the manifold circuit board as indicated by the labeling instruction (see page 33). Remote master alarm signal and common wires must also be connected to the manifold circuit board as indicated by the labeling instructions on the back of the circuit board cover.

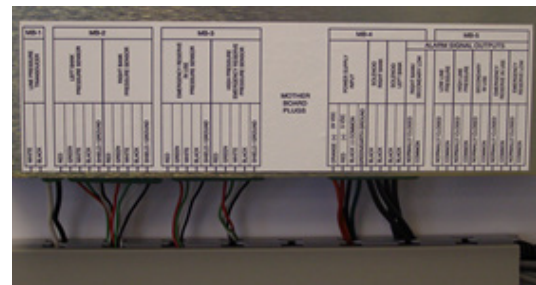
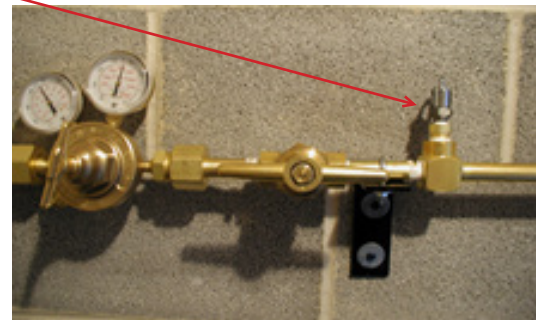
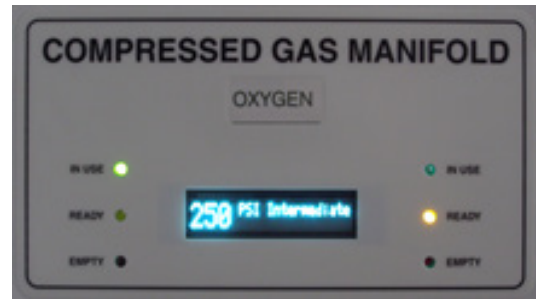
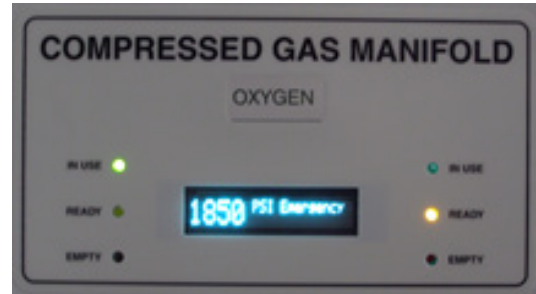

Cylinder Replacement & Handling

- Close all cylinder valves on the depleted bank.
- SLOWLY loosen and remove the pigtail connection from the depleted cylinders.
- Remove depleted cylinders and replace protective caps.
- Place and secure full cylinders into position using chains, belts or cylinder stands.
- Remove protective cylinder caps from full replacement cylinders. With the valve outlet pointed away from all people in the area, slowly open each cylinder valve slightly for a split second to blow out any dirt or contaminants that may have become lodged into the cylinder valve.
- Connect pigtails to cylinder valves and tighten with wrench.
- SLOWLY turn each cylinder valve until each cylinder is fully on.
- Leak test the connections using an oxygen approved leak test solution.
- Observe the following conditions: The red (Empty) LED is extinguished and the yellow (Ready) LED is illuminated and the secondary in use alarm is cancelled.
- The manifold supply bank is now replenished and automatically placed in “reserve”.



Line Delivery Pressure Adjustment

- Leave the manifold in full operational status.
- Create a flow condition in the delivery piping system. DISS demand valves have been provided on the line regulators for this purpose. Mating DISS fittings may be used to create a flow of gas within the manifold cabinet.
- Open the manifold cabinet door and locate the line pressure regulators. Ball valves on the inlet and outlet sides of each regulator determine which regulator is “on line” and which is “off line”. Note: when the ball valve handle is perpendicular to the pipeline, the ball valve is closed. One line regulator should be valved closed and the other valved open. The line regulators on-line and off-line should be alternated every other month to ensure each is exercised.
- Turn the T – bar handle clockwise to increase pressure or counter-clockwise to decrease pressure. It may be necessary to use a 3/4” open-end wrench, loosen the locknut on the adjusting screw (on high flow models only).
- After adjustment, retighten the locknut on the adjusting screw and close the cabinet door.

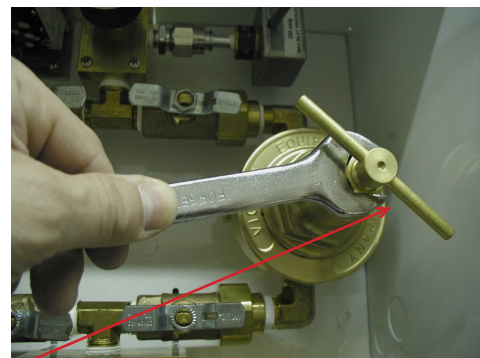
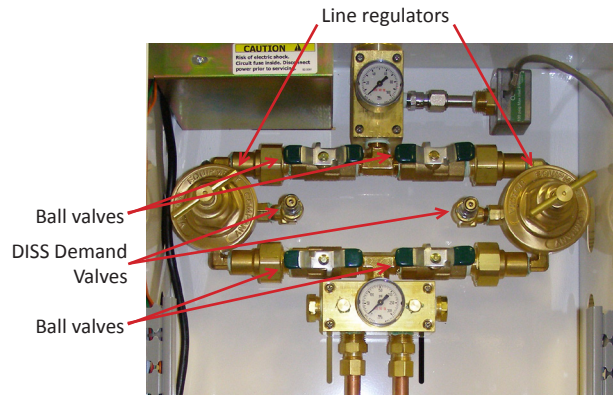

T-bar handle

Programming Adjustments

The manifold is pre-programmed and tested before it is shipped. You may, however, wish to modify some of the programming. The unit has been designed to allow some programming to be simply and safely altered in the field. The aspects of the program which may be altered include:

- Low line pressure set point
- High line pressure set point
- Units of measure (psig, bar or kPa)
- Calibrate line sensor
- Display scroll time (seconds)

Application logic (this should only be changed if the unit is being converted to a new application – in conference with a factory technician)

- To make any programming change, the cover must be removed from the circuit board and the top #1 dip switch must be switched from the RUN mode to the PROGRAM mode.
- Once the #1 dip switch has been changed from the RUN mode to the PROGRAM mode, the display should look like this
- While viewing the display on the front of the cabinet door, use the NEXT or PREVIOUS buttons to toggle thru the menu choices. When you find the item you wish to reprogram, use the UP or DOWN buttons to display the new setting desired and then use the ENTER button to save changes to the programming. Note – if the ENTER button is not pressed for each and every change, that programming change will not be saved. The display will display the word SAVED when you have successfully saved a programming change.
- Return the dip switch to the RUN position and replace the circuit board cover when you are finished making changes to the programming.

Program control buttons

Dip switch #1 Run/Program

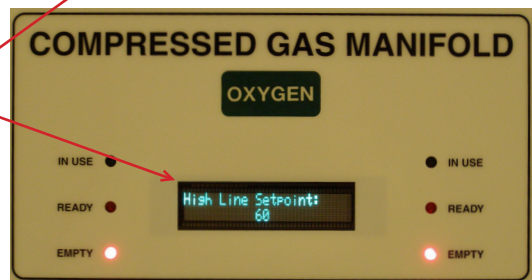
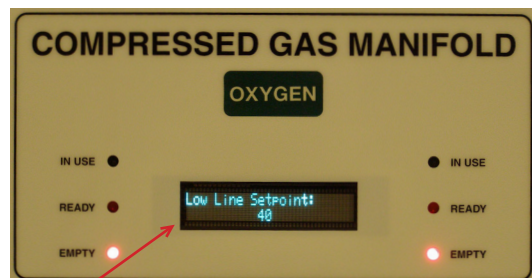
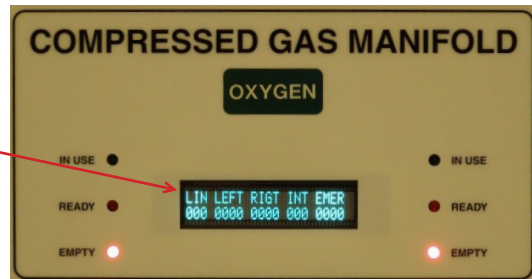
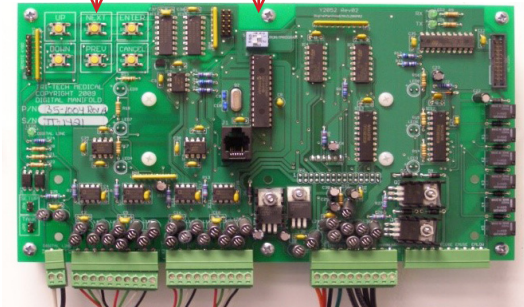

Displays showing common pre-programmed alarm set points

General Maintenance

Interval	Control Cabinet	Headers & Pigtails
Daily	Record line and bank pressures	Observe nitrous oxide and carbon dioxide systems for cylinder frosting or surface condensation. Should excessive condensation or frosting occur it may be necessary to increase manifold capacity.
Monthly	Check regulators, compression fittings and valves for external leakage. Check valves for closure ability. Alternate line regulator in use (if dual).	Inspect valves for proper closure. Check pigtails for cleanliness, flexibility, wear, leakage, kinked, pinched or twisted and thread damage. Replace damaged pigtails immediately. Inspect header check valve outlets for closure ability.
Annually	Check relief valve pressures. Check regulator seats. Tighten regulator bonnets 1 to 2 degrees (out of 360).	
Every 4 years		Replace all pigtails
Every 10 years	Rebuild or replace: all regulators, PX-17-4003 intermediate check valves, PX-48-1008 & PX-48-1009 solenoid valves, and DISS demand check valves.	Rebuild or replace master valves. Replace all check valve outlets.

Error Codes, Alarm Codes, & Information Codes

Code Displayed	Message Displayed	Explanation
Error 01	Left bank sensor out of range	This condition is activated when the left sensor's raw readings are at either extreme. Can be caused by a disconnected, wired incorrectly, bad, or over-pressurized sensor.
Error 02	Right bank sensor out of range	This condition is activated when the right sensor's raw readings are at either extreme. Can be caused by a disconnected, wired incorrectly, bad, or over-pressurized sensor.
Error 03	Intermediate pressure out of range	This condition is activated when the intermediate sensor's raw readings are at either extreme. Can be caused by a disconnected, wired incorrectly, bad, or over-pressurized sensor.
Error 04	Emergency reserve out of range	This condition is activated when the emergency sensor's raw readings are at either extreme. Can be caused by a disconnected, wired incorrectly, bad, or over-pressurized sensor.
Error 07	Intermediate pressure high	Message is displayed whenever the intermediate pressure exceeds 500 psi.
Error 08	Emergency reserve pressure high	Message is displayed whenever the high pressure emergency reserve bank pressure exceeds 3,000 psi.
Error 09	Line sensor noise detected	Message is displayed if a gas board detects noise in the signal from it's digital sensor
Error 10	Line sensor failed to respond	Message is displayed if a line sensor is not responding.
Error 11	Line sensor is disconnected	Message is displayed whenever a line sensor is disconnected.
Error 12	Secondary supply leak detected	Message is displayed when a leak is detected in the secondary bank.
Error 13	Emergency reserve leak detected	Message is displayed when a leak is detected in the emergency reserve bank.
Error 14	Gas type mismatch	This error code is triggered by a mismatch in gas type between the line sensor and user selected gas type in setup of the manifold circuit board.

Error Codes, Alarm Codes, & Information Codes

Code Displayed	Message Displayed	Explanation
Alarm 01	Line pressure low	Message is displayed and low line pressure relay activated whenever the line pressure is below the programmed low line pressure alarm set point.
Alarm 02	Line pressure high	Message is displayed and high line relay activated whenever the line pressure is above the programmed high line pressure alarm set point (high line pressure alarm is triggered).
Alarm 03	Secondary supply in use	Message is displayed and secondary in use relay activated when the manifold has switched over to the secondary bank. Clears when tank is replaced.
Alarm 04	Emergency reserve in use	Message is displayed and emergency in use relay activated whenever the intermediate pressure is below the programmed emergency in use pressure alarm set point. (LL models only).
Alarm 05	Emergency reserve pressure low	Message is displayed and emergency low relay activated whenever the emergency pressure is below the programmed emergency reserve low pressure alarm set point. (LL models only).
Alarm 06	Right bank / Secondary low	Message is displayed and low line pressure relay activated whenever the right bank pressure is below 1,200 psig factory pre-set or pressure set point as re-programmed in the field. (PL models only)
Info 01	Economizer in use	Message is displayed whenever the ready bank pressure exceeds the service bank pressure by 50 psig or more. The logic compares the service and ready bank pressures once a second. (LL models only).
	XX% Remains	(emergency reserve only - except for N2O & CO2 services). It calculates and displays the percent of gas remaining in the emergency reserve bank.

Definitions and clarifications

Alarm Code – Alarm conditions per NFPA 99C and Z7396.1 guidelines.

Error Code – Messages that provide diagnostic information to assist in resolving system problems.

Information Codes – Messages that provide information regarding the operation of the system.

Replacement Parts & Accessories

Item	Part #	Description
Line Regulators & Repair Kits	PX-68-0004R	Line regulator standard flow 5 - 125 psig
	PX-68-0004RK	Standard flow line regulator repair/rebuild kit
	PX-68-0002R	Line regulator high flow 5 - 125 psig
	PX-68-0002RK	High flow line regulator repair/rebuild kit 5 - 125 psig
	PX-68-0001R	Line regulator high flow 10-200 psig
	PX-68-0001RK	High flow line regulator repair/rebuild kit 10 - 250 psig
Circuit Board	PX-35-1004R	LL/PL series PLC board with single text display
Power Supply	PX-35-2013R	Power supply
Transducers/Sensors	PX-14-3001-12R	0 - 2,500 psig transducer with 12' cable for emergency reserve low (both LL and PL models)
	PX-14-3001-5R	0 - 2,500 psig transducer with 15' cable for right bank low (PL models only)
	PX-14-3002	0 - 500 psig transducer with 3' cable for left or right banks and emergency reserve in use
	PX-14-3024	0 - 250 psig transducer with 1.5' cable N2
	PX-14-3025	0 - 100 psig transducer with 1.5' cable Oxygen
	PX-14-3028	0 - 100 psig transducer with 1.5' cable Med Air
	PX-14-3027	0 - 100 psig transducer with 1.5' cable N2O
	PX-14-3028	0 - 100 psig transducer with 1.5' cable CO2
Solenoid Valves	PX-48-1008R	Left solenoid valve for LL/PL series
	PX-48-1009R	Right Solenoid valve for LL / PL series
Check Valve	PX-17-4003R	Intermediate check valve 1/2 npt male x 1/2 OD tube
Tubes & Compression Fittings	PX-17-4012	Compression Sleeve 1/2 OD tube - glass filled Teflon
	PX-17-4005	Compression Nut for 17-4012
	PX-Q1100-1	1/2 OD copper tube x 7"
	PX-17-4013	Compression Sleeve 3/8 OD tube - glass filled Teflon
	PX-17-4024	Compression Nut for 17-4013
Gauges	PX-14-1018	0 - 4,000 psig 1 1/2" x 1/8 m npt center back gauge
	PX-14-1016	0 - 400 psig 2" x 1/4 m npt bottom port gauge
	PX-14-1017	0 - 400 psig 1 1/2" x 1/8 m npt center back gauge
	PX-14-1009	0 - 300 psig 1 1/2" x 1/8 m npt center back gauge
	PX-14-1008	0 - 100 psig 1 1/2" x 1/8 m npt center back gauge
Relief Valves	PX-RV-22-075	75 psig x 1/2 M npt inlet with pipe away adaptor
	PX-RV-22-150	150 psig x 1/2 M npt inlet with pipe away adaptor
	PX-RV-22-250	250 psig x 1/2 M npt inlet with pipe away adaptor
	PX-RV-11-400	400 psig x 1/4 M npt inlet with pipe away adaptor
Pigtails	PX-20-1001	36" (pre-bend) single loop rigid copper O2 (w/o check) – CGA 540
	PX-20-1002	36" single loop rigid copper N2O – CGA 326
	PX-20-0002	24" Flexible stainless braided N2O - CGA 326 with captured fittings
	PX-20-0003	24" Flexible stainless braided CO2 – CGA 320 with captured fittings
	PX-20-0004	24" Flexible stainless braided AIR – CGA 346 with captured fittings
	PX-20-0005	24" Flexible stainless braided N2 – CGA 580 with captured fittings

Replacement Parts & Accessories (Continued)

Item	Part #	Description
Union	PX-17-0169	Union 3 piece 1/2" M npt x 1/2" M npt 1" 11 1/2 NPS
Master Valve	PX-17-0256	Master Valve 1/2" F npt x 1/2 F npt
Master Valve Repair Kit	PX-GMV-1001RK	Master valve rebuild kit
Heater element	PX-35-2001	Ceramic Heater
Accessory	PX-35-3012	Manifold buzzer kit
Pigtails for RWP & RSP Models	PX-20-1001	24" single loop rigid copper O2 – CGA 540
	PX-20-0001	24" Flexible stainless braided O2 - CGA 540
	PX-20-1002	24" single loop rigid copper N2O – CGA 326
	PX-20-0002	24" Flexible stainless braided N2O - CGA 326
	PX-20-0003	24" Flexible stainless braided CO2 – CGA 320
	PX-20-0004	24" Flexible stainless braided AIR – CGA 346
	PX-20-0005	24" Flexible stainless braided Inert – CGA 580
Pigtails for LL, TML & PL Models	PX-20-2001	72" Flexible – O2 – CGA 540
	PX-20-2002	72" Flexible – N2, Ar, He– CGA 580
	PX-20-2003	72" Flexible – CO2 – CGA 320
	PX-20-2004	72" Flexible – N2O – CGA 326
Union for Line Vent	PX-17-0169	Union 3 piece 1/2" M npt x 1/2" M npt 1 1/4 - 14 UNS
Union for Intermediate Vent	PX-17-0271 (2 required)	Union 3 piece 3/8" M npt x 1/2" M npt 1 1/4 - 14 UNS
Master Valve	PX-17-0256	Master Valve 1/2" F npt x 1/2 F npt
Master Valve Repair Kit	PX-GMV-1001RK	Master valve rebuild kit
	PX-35-3013	High Pressure Reserve Jumper Kit
Heater element	PX-35-2001	Ceramic Heater
Accessory	PX-35-3012	Manifold buzzer kit

Troubleshooting Guide

NOTE: Troubleshooting and repairs should be done by qualified personnel only.

Component	Symptom	Probable Cause	Remedy or Check
Circuit board	No indicator lights on front panel illuminate when power is connected.	Wiring connection.	Check wiring connections.
		Power input out of range	Check electrical power supply output voltages.
		Bad circuit board	Replace power supply or circuit board.
	Red indicator lights are on but both banks are full	Master valve or cylinder valves on bank are closed.	Open valves SLOWLY
		Pigtails are installed with check valves in wrong direction	Close cylinders and re-install pigtails in proper flow direction
		Bank pressure is not sufficient for logic board to place it in "In Use" or "Ready" status (see appendix E minimum inlet pressures page 27)	Replace cylinders with full cylinders. Or, if using portable bulk vessels, open pressure building valve on vessel or replace portable bulk vessel with higher delivery pressure portable bulk vessel
	Error code(s) being displayed	Loose or disconnected or broken wire, mis-connected wire, a bad transducer, a calibration problem or an over-pressure situation.	Check wires for good and correct location connection to circuit board (See ERROR CODES pg 15)
			If all wires are connected properly and located properly – it may be necessary to replace a transducer.
Entire manifold	Loss of cylinder contents	Leakage in manifold cabinet, headers or pigtails.	Locate leak using oxygen compatible leak test solution, tighten, reseal or replace leaking fitting(s) or pigtails.
		Leakage thru manifold solenoid vent / relief	Replace solenoid valve
		Leakage around regulator bonnet	Tighten regulator bonnet
		Regulator with bad seat	Rebuild or replace regulator
		Leaking gauge	Replace gauge
		Regulator set too high	Set delivery pressure per specifications (see page 27)
		Overpressure due to failed regulator seat	Rebuild or replace regulator
		Regulator freeze-up (N2O or CO2) / heater failure	Flow rate exceeds manifold design capacity or cylinder withdrawl capacity – add cylinders.
			Repair heater or add heater and consider adding additional cylinders

Troubleshooting Guide (Continued)

Component	Symptom	Probable Cause	Remedy or Check
Loss of cylinder contents	Both banks feeding	Leaking header/pigtail connection	Tighten fitting or re-tape with Oxygen safe Teflon tape (if npt fitting) and tighten.
		Leaking intermediate check valve	Replace check valve
		Leaking solenoid valve	Replace solenoid valve
		Inlet pressure to control cabinet is too low	Verify that minimum inlet pressure requirements are met per chart on page 31
		Portable bulk vessel is venting	Gas usage is not sufficient to justify portable bulk reserve
		Gas flowing thru the economizer circuit	This is normal when the reserve bank pressure is 50 psig greater than the service bank pressure – no correction needed to manifold control cabinet. May consider reducing the number of liquid vessels on each bank if the reserve bank is more than 35% depleted at the time it is placed in service.
			If gas is flowing thru the economizer when the reserve bank pressure is not 50 psig greater than the service bank pressure – the economizer check valve needs to be replaced.
Manifold is unable to support required flow (N2O or CO2 units)	Increase manifold flow capacity (call factory for assistance)		
System	Changeover occurs, secondary in use alarm is triggered and then clears placing empty or near empty bank into reserve	Manifold is unable to support required flow (N2O or CO2 units)	Increase manifold flow capacity (call factory for assistance)
			Increase bank size
			If using two or more portable bulk vessels per bank currently, connect pigtail(s) (no check valve) from vent to vent of all vessels on the same bank and open the vent valves. This will equalize the head pressures and utilize the combined vaporization capacity – not just the vaporization capacity of the vessel with the highest delivery set point.

Appendix A

Glossary of Terms

AC	Alternating Current An electric current that reverses direction or polarity at regular intervals.	NC	Normally Closed An electrical circuit in which the switch is normally closed. Current flows through the circuit in normal operation. Only when the switch is opened is the flow of current stopped.
Alarm Code	Alarm conditions per NFPA 99C guidelines.	PSI	Pounds per Square Inch A measurement of the force in a compressed gas system. 1 PSI = 6.9 kPa
BAR	Bar A measurement of the force in a compressed gas system. 1 BAR = 14.7 psig (1 atmosphere)	Solenoid Valve	A valve that is opened or closed electromagnetically.
Check Valve	A valve which operates mechanically and automatically to stop a reverse flow of gas.	Transducer	A device that converts pressure into an electrical signal.
DC	Direct Current An electric current that flows in one direction. The current can be steady or pulse.	Transient Signal	An intermittent and brief signal that quickly corrects and returns the alarm to a normal operating mode before monitoring personnel can silence the alarm
Economizer Circuit	A mechanical piping circuit which allows built up reserve gas to be used in low volume rather than allowing the gas to vent to atmosphere.	V	Voltage Voltage is electrical pressure or force. One volt is equal to the difference of electrical potential between two points on a conducting wire carrying a constant current of one ampere when the power dissipated between the points is one watt.
Information Code	Messages that provide information regarding the operation of the system.		
KPa	Kilopascals A measurement of the force in a compressed gas system. 1 kPa = .14 PSI		
LED	Light Emitting Diode A semiconductor diode that converts applied voltage to light.		
NFPA	National Fire Protection Association The National Fire Protection Association is an association engaged in standards development.		
NO	Normally Open An electrical circuit in which the switch is normally open. No current flows through the circuit in normal operation. Only when the switch is closed is the flow of current started. A normally open solenoid valve is one designed so that it is open when there is no power to the solenoid and closed when it is energized.		

Appendix B

Technical Specifications

Maximum Inlet Pressure:	Emergency Reserve (both LL & PL Models)	3000 psig
	Right bank (secondary) model PL only	3,000 psig
	Cabinet models LL & PL:	400 psig

Operating Ambient Temperature range: -20 F (-29 C) to 125 F (54.4 C)

Storage Temperature: -20 F(-29 C) to 185 F (85 C)

AC Input: 120 volts AC - 50-60 Hz

Input Fuse: 5 amp input AC line fuse protects the input wiring to power supply

Power Consumption: 45W (0.4 amps using 120 VAC) maximum without heaters
245W (2.1 amps using 120 VAC) maximum with heaters

Full Load Amps: .375 without heaters
2.10 with heaters

Pressure Measurement Accuracy: 0-100 PSIG transducer +/-1% of full scale – Line Pressure – Oxygen, Nitrous Oxide, Medical Air, Carbon Dioxide
0-250PSIG transducer +/-1% of full scale – Line Pressure – Nitrogen
0 500 PSIG transducer +/-2% of full scale – Bank & Intermediate Pressures model LL only
0 – 2,500 PSIG transducer +/-2% of full scale – Bank Pressures model CC, Emergency Reserve Bank Pressure model LL

Solenoid Valve: 24VDC – Normally Open (Valve opens when de-energized)

Dimensions

Control Cabinet: Dimensions excluding inlet & outlet fittings
15 3/8" W x 25" H x 9 1/4" D

Dimensions including inlet & outlet fittings
17 1/4" W x 27" H x 9 1/4" D

Line Pressure Transducers: Housing dimensions: 1.25" Diameter x 3.75" Length including inlet fittings

Weatherproof Control Cabinet: Dimensions excluding inlet & outlet fittings
17 1/4" W (cabinet) 18 3/4"W (door) x 26 3/4" H x 11" D

Dimensions including inlet & outlet fittings
20 1/4" W x 29" H x 11" D

Appendix C

Operational Pressure Specifications

Minimum inlet pressure requirements for LL Manifold

Manifold delivery pressure	Minimum inlet pressure	Relief valve setting on vessel
50	135	235
80	135	235
170	250	350

Minimum inlet pressure requirements for PL Manifold

Manifold Delivery Pressure	Minimum Inlet Pressure Left Bank	Regulator Setting Right Bank	Minimum Bank Pressure Right Bank
50	135	150	1,200 (factory pre-set right bank low pressure alarm)
80	300	250	1,200 (factory pre-set right bank low pressure alarm)
170	300	250	1,200 (factory pre-set right bank low pressure alarm)

Line Pressure Alarm Pressure Settings for LL Models

Normal Delivery Press	Line Relief Setting	High Line Press Set Point	Low Line Press Set Point	Secondary In Use Set Point
50	75	60	40	95 both banks
80	150	96	64	95 both banks
170	250	200	140	190 both banks

Line Pressure Alarm Pressure Settings for PL Models

Normal Delivery Press	Line Relief Setting	High Line Press Set Point	Low Line Press Set Point	Secondary In Use Set Point
50	75	60	40	95 both banks
80	150	96	64	95 both banks
170	250	200	140	190 both banks

Alarm Pressure Settings for LL & PL Models Emergency Reserve In Use & Emergency Reserve Low

Manifold Delivery Pressure	Recommended Emergency Reserve Regulator Delivery Pressure Setting	Pre-programmed Emergency Reserve In Use Alarm Set Point	Pre-programmed Emergency Reserve Low Alarm Set Point
50	65	75	1200
80	70	80	1200
190	170	180	1200

Appendix D

Wiring Diagram

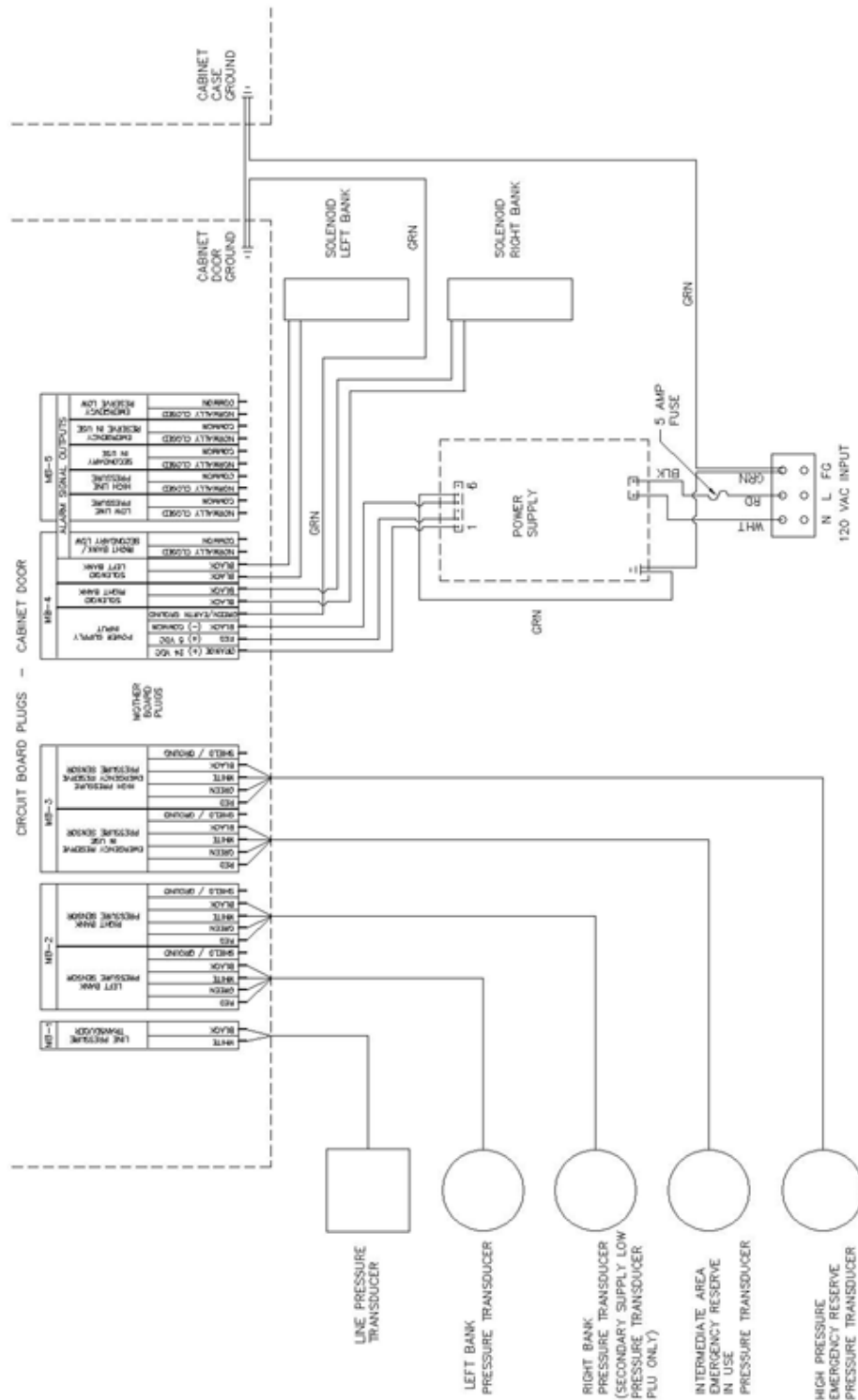

Appendix E

Wiring Diagram for Buzzer Kit

Buzzer Kit Part# PX-35-3012

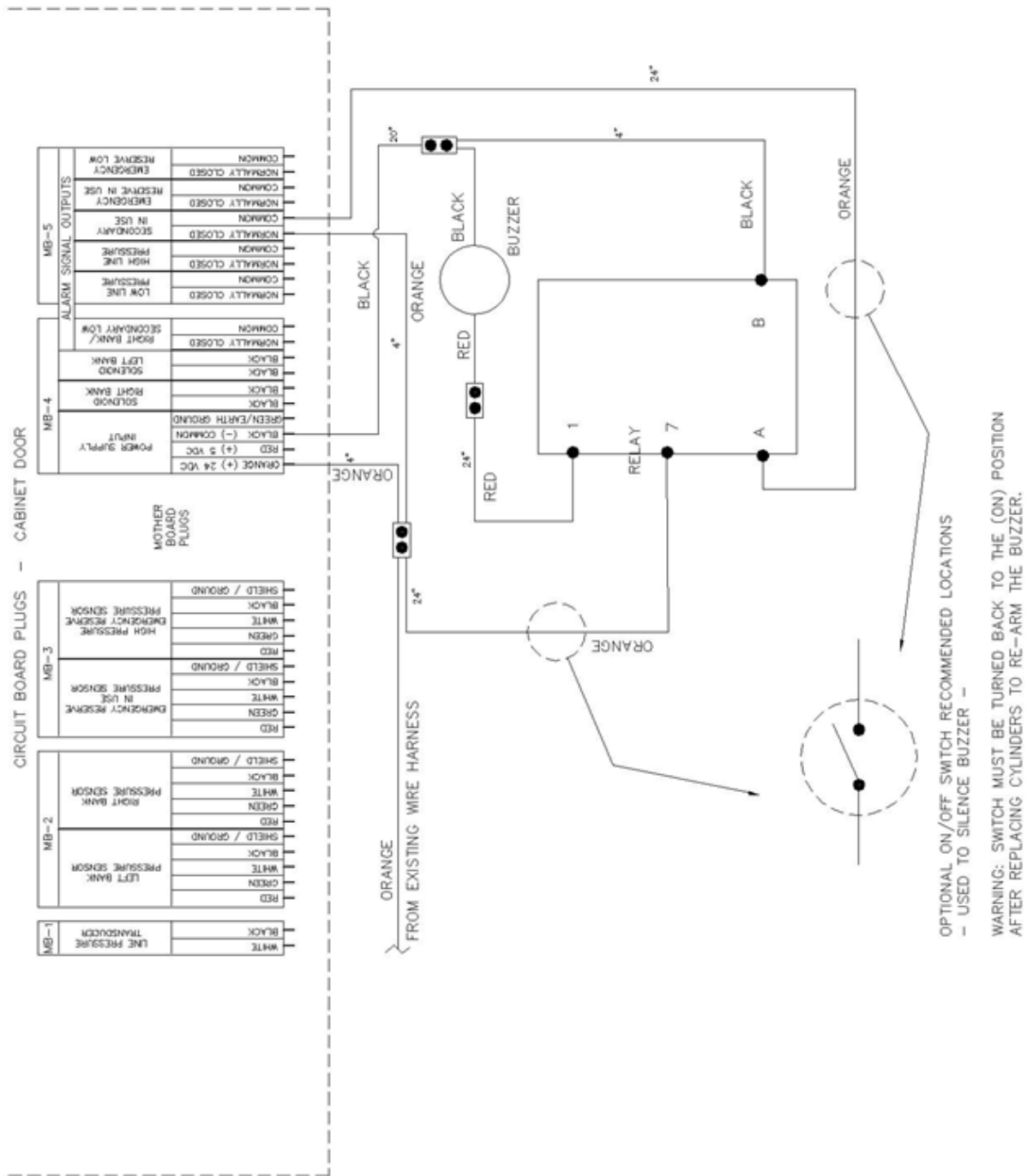

Buyer's purchase order is subject to the following conditions of sale:

Powerex Limited Warranty

Warranty and Remedies. (a) Standard Period of Warranty – Parts and Labor. Powerex warrants and represents all Products shall be free from Defects for the first twelve (12) months from the date of shipment by Powerex. During such warranty period, Powerex shall be fully liable for all Defects in the Products (the "Product Defects"), i.e., all costs of repair or replacement, which may include "in and out" charges, so long as the Products are located in the United States or Canada, and the Products are reasonably located and accessible by service personnel for removal. "In and out" charges include the costs of removing a Product from buyer's equipment for repair or replacement.

(b) Additional Period of Warranty – Parts Only (No Labor). In addition to the above, Powerex warrants the products described herein to be free from defects in material and workmanship for forty-eight (48) months from end of Standard Period of Warranty with the exception of any components which are recommended to be replaced in less than sixty months in our Installation/Operation manuals. Within said period Powerex will repair or replace any part or component which is proven to be defective in either material or workmanship. This warranty covers parts only. Labor is not included. This warranty is valid only when the product has been properly installed according to Powerex specifications, used in a normal manner and serviced according to factory recommendations. This warranty does not cover failures due to damage which occurs in shipment or failures which result from accidents, misuse, abuse, neglect, mishandling, alteration, misapplication or damage due to acts of nature.

(c) General. Powerex warrants each Powerex branded Pipeline Accessory (collectively "Products", individually each a "Product") to be free from defects in material and workmanship ("Defects") at the date of shipment. EXCEPT AS SET FORTH BELOW, NO OTHER WARRANTY, WHETHER EXPRESS OR IMPLIED, INCLUDING ANY WARRANTY OF MERCHANTABILITY OR FITNESS FOR A PARTICULAR PURPOSE, SHALL EXIST IN CONNECTION WITH THE SALE OR USE OF SUCH PRODUCTS. TO THE EXTENT PERMITTED BY LAW, ANY AND ALL IMPLIED WARRANTIES ARE EXCLUDED. All warranty claims must be made in writing and delivered to Powerex in accordance with the procedures set forth on its website (www.powerexinc.com), or such claim shall be barred. Upon timely receipt of a warranty claim, Powerex shall inspect the Product claimed to have a Defect, and Powerex shall replace any Product which it determines to have had a Defect; provided, however, that Powerex may elect, upon return of the Product, to refund to buyer any part of the purchase price of such Products paid to Powerex. Freight for returning Products to Powerex for inspection or for shipping warranty parts shall be paid by buyer where permitted by applicable law. Powerex is not responsible for any import fees, taxes, duties, licenses or other fees imposed by any governmental authority upon the production, sale, shipment and/or use of Products covered hereunder. The warranties and remedies herein are the sole and exclusive remedy for any breach of warranty or for any other claim based on any Defect, or non-performance of the Products, whether based upon contract, warranty or negligence.

(d) Coverage. The warranty provided herein applies to Powerex pipeline products only.

(e) Exceptions. Notwithstanding anything to the contrary herein, Powerex shall have no warranty obligations with respect to Products:

(i) That have not been installed in accordance with Powerex's written specifications and instructions;

(ii) That have not been maintained in accordance with Powerex's written instructions;

(iii) That have been materially modified without the prior written approval of Powerex; or

(iv) That experience failures resulting from operation, either intentional or otherwise, in excess of rated capacities or in an otherwise improper manner.

The warranty provided herein shall not apply to: **(i)** any defects arising from corrosion, abrasion, use of insoluble lubricants, or negligent attendance to or faulty operation of the Products; **(ii)** ordinary wear and tear of the Products; or **(iii)** defects arising from abnormal conditions of temperature, dirt or corrosive matter; **(iv)** any OEM component which is shipped by Powerex with the original manufacturer's warranty, which shall be the sole applicable warranty for such component.

Limitation of Liability. NOTWITHSTANDING ANYTHING TO THE CONTRARY HEREIN, TO THE EXTENT ALLOWABLE UNDER APPLICABLE LAW, UNDER NO CIRCUMSTANCES SHALL POWEREX BE LIABLE FOR ANY INCIDENTAL, CONSEQUENTIAL, PUNITIVE, SPECULATIVE OR INDIRECT LOSSES OR DAMAGES WHATSOEVER ARISING OUT OF OR IN ANY WAY RELATED TO ANY OF THE PRODUCTS OR GOODS SOLD OR AGREED TO BE SOLD BY POWEREX TO BUYER. TO THE EXTENT ALLOWABLE UNDER APPLICABLE LAW, POWEREX'S LIABILITY IN ALL EVENTS IS LIMITED TO, AND SHALL NOT EXCEED, THE PURCHASE PRICE PAID. In the event of breach of any warranty hereunder, Powerex's sole and exclusive liability shall be at its option either to repair or to replace any defective product, or to accept return, transportation prepaid, of such product and refund the purchase price; in either case provided that written notice of such defect is given to Powerex within twelve (12) months from date of shipment to Buyer, that the product is found by Powerex to have been defective at the time of such shipment, that the product has been installed and/or operated in accordance with Powerex's instructions,

that no repairs, alterations or replacements have been made by others without Powerex's written approval, and that Buyer notifies Powerex in writing within fifteen (15) days after the defect becomes apparent and promptly furnishes full particulars in connection therewith; and provided further that in no event shall the aggregate liability of Powerex in connection with breach of any warranty or warranties exceed the purchase price paid for the product purchased hereunder. Powerex may, at its option, require the return of any product, transportation and duties prepaid, to establish any claim of defect made by Buyer. Unless otherwise agreed in writing **(a)** Powerex will not accept and shall have no responsibility for products returned without its prior written consent, and **(b)** Powerex will not assume any expense or liability for repairs to products made outside of its plant by third parties. In the event Powerex elects to replace a defective product, costs of installation, labor, service, and all other costs to replace the product shall be the responsibility of Buyer.

Powerex shall not, except as set forth above, be otherwise liable to Buyer or to any person who shall purchase from Buyer, or use, any products supplied hereunder for damages of any kind, including, but not limited to, indirect, special or consequential damages or loss of production or loss of profits resulting from any cause whatsoever, including, but not limited to, any delay, act, error or omission of Powerex. Supplier's repair or replacement of any Product shall not extend the period of any warranty of any Product.

Warranty Disclaimer. Powerex has made a diligent effort to illustrate and describe the Products in its literature, including its Price Book, accurately; however, such illustrations and descriptions are for the sole purpose of identification, and do not express or imply a warranty that the Products are merchantable, or fit for a particular purpose, or that the Products will necessarily conform to the illustrations or descriptions.

Product Suitability. Many jurisdictions have codes and regulations governing sales, construction, installation, and/or use of Products for certain purposes, which may vary from those in neighboring areas. While Powerex attempts to assure that its Products comply with such codes, it cannot guarantee compliance, and cannot be responsible for how the product is installed or used. Before purchase and use of a Product, please review the Product applications, and national and local codes and regulations, and be sure that the Product, installation, and use will comply with them.

Claims. Any non-warranty claims pertaining to the Products must be filed with Powerex within (6) months of the invoice date, or they will not be honored. Prices, discounts, and terms are subject to change without notice or as stipulated in specific Product quotations. Powerex shall not be liable for any delay or failure arising out of acts of the public enemy, fire, flood, or any disaster, labor trouble, riot or disorder, delay in the supply of materials or any other cause, whether similar or dissimilar, beyond the control of Company. All shipments are carefully inspected and counted before leaving the factory. Please inspect carefully any receipt of Products noting any discrepancy or damage on the carrier's freight bill at the time of delivery. Discrepancies or damage which obviously occurred in transit are the carrier's responsibility and related claims should be made promptly directly to the carrier. Returned Products will not be accepted without prior written authorization by Powerex and deductions from invoices for shortage or damage claims will not be allowed. **UNLESS OTHERWISE AGREED TO IN WRITING, THE TERMS AND CONDITIONS CONTAINED IN THIS LIMITED WARRANTY WILL CONTROL IN ANY TRANSACTION WITH POWEREX.** Any different or conflicting terms as may appear on any order form now or later submitted by the buyer will not control. All orders are subject to acceptance by Powerex.

Notes
