

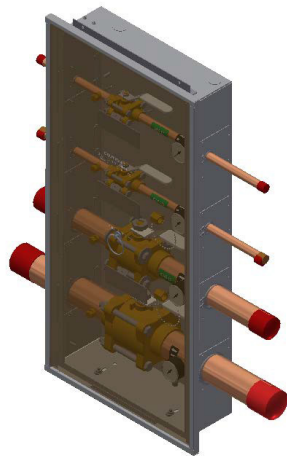

## Installation & Operating Instructions for Zone Valve Boxes & Ball Valves

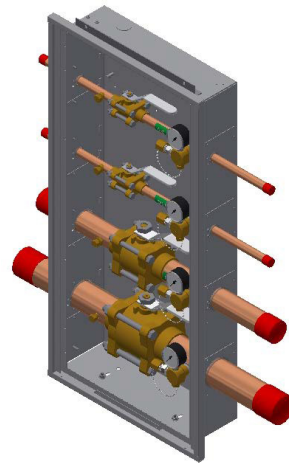

V Series Zone Valve Box



EV Series Zone Valve Box

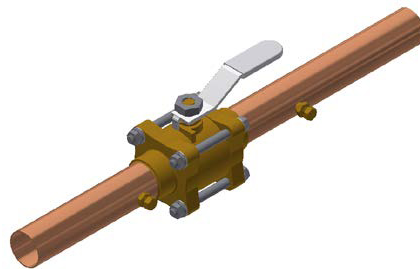

Ball Valve

## Introduction

The Powerex ball valves and zone valve boxes are cleaned for use with oxygen. Each valve is tested for leakage in both the open and closed position. Each unit is designed and built in accordance with the National Fire Protection Association and Compressed Gas Association guidelines. The installation and maintenance should be conducted in accordance with the following standards: NFPA 99C or CSA Z7396.1-06.

## Warranty

All Powerex manifolds are warranted against defects in material and workmanship for the period of one year from date of purchase.

Ball valves must be inspected periodically for closure ability and leakage. A defective product should be repaired or replaced immediately. Parts that are broken, missing, worn, distorted or contaminated should be replaced immediately.

## Installation of Ball Valves

Ball valves must be installed in accordance with NFPA99 or CSAZ7396.1-06. Verify the valve is in the fully open position. An internal nitrogen purge must be used during the brazing operation. The purge gas should flow away from the valve body. Brazing alloys per appropriate standards must be used. Before brazing, wet rags must be wrapped around the tube extensions next to the valve flanges to prevent overheating and possible damage to the valve seals. Direct the flame away from the valve body. The valve body temperature must not exceed 300 degrees F to prevent damaging the Teflon seals. Do not braze the opposite side of the valve assembly until after the first side has cooled.

Note: The valve bolts may need to be re-tightened after brazing due to the effects of heating & cooling. Torque the the hex nuts in ¼ turn increments, using a cross pattern until the proper torque setting is reached per the chart below:

Valve Size	Torque (inch-pounds)
1/2"	65
3/4" and 1"	75
1 1/4" to 1 1/2"	125
2"	200

The system must be tested (per appropriate standards) to ensure that no cross-connections have been made.

The system must be tested (per appropriate standards) for leaks.

Gauges should not be installed until after the leak testing is completed. Excessive pressure will damage the gauges.

Note: Pressure in the system will increase or decrease with temperature rise or fall.

After the system passes the leak test, gauges may be installed. Pipe sealants used to install the gauges must comply with NFPA 99 or CSA Z7396.1-06. Use care to exclude pipe sealants from the valve cavity and from interior tube surfaces exposed to medical gas flow or vacuum service. Properly applied Teflon tape is an acceptable alternative to pipe sealants.

Check shutoff valve handle operation for proper clearance from any obstructions.

**⚠ WARNING** *Miss-connection of the gases could lead to serious or fatal injury to patients. Following installation, valves must be tested for cross-connection (per appropriate standards) to ensure that the intended services are correctly connected to the appropriate service lines.*

## Zone Valve Box Installation

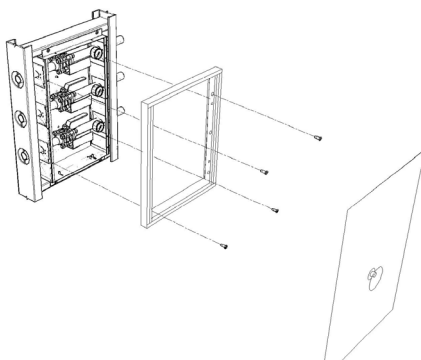
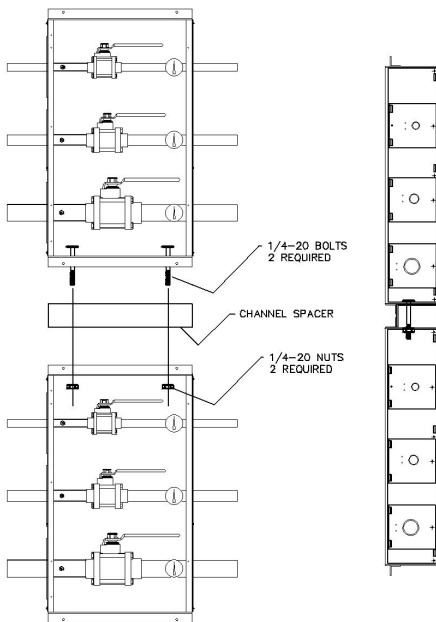
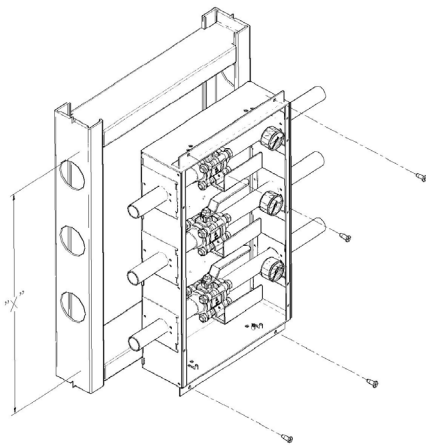

1. Powerex Zone Valve Boxes may be plumbed in either direction – with the patient (use) side on the left or the right. The dual gauge ports allow for installation of the gauge on either side of the valve. This saves the plumber time and money.
2. The rough-in (back box) is shipped with a cardboard dust cover installed. You will need to remove the dust cover to install the rough-in and perform the pressure test. The dust cover should be re-installed after the pressure test to protect the valves until the wall covering (drywall, paint etc.) is complete.
3. Adjustable depth mounting flanges (top & bottom) should be utilized to align front edge of box to be flush with the drywall surface.
4. The center of the rough-in box should be 60" in height above the finished floor. Fasten the valve box to horizontal braces installed between the studs so that the front edge of the rough in box will be flush or slightly recessed with the finished wall covering.
5. Before brazing, remove the plastic tube caps from the valves. Ball valves must be installed in accordance with "Installation of Ball Valves" instructions on page 2.
6. The system must be tested (per appropriate standards) to ensure that no cross-connections have been made. The system must be tested (per appropriate standards) for leaks. Gauges should not be installed until after the leak testing is completed. Excessive pressure will damage the gauges. NOTE: Pressure in the system will increase or decrease with temperature rise or fall.
7. If more than 4 valves are required, multiple zone valve boxes may be installed using a ZV-801 zone valve box coupling kit as shown here.
8. After the system passes the leak test, gauges may be installed. Gauges must be installed on the downstream (patient) side of the valve. Pipe sealants used to install the gauges must comply with NFPA 99 or CSA Z7396.1-06. Use care to exclude pipe sealants from the valve cavity and from interior tube surfaces exposed to medical gas flow or vacuum service. Properly applied Teflon tape is an acceptable alternative to pipe sealants.
9. Mark the areas controlled by each valve on the labels provided on each valve.
10. After the wall covering is complete, the dust cover may be removed from the rough-in box and the window frame and window may be installed.

**⚠ WARNING**

*Make certain the labeling coincides with the gas service, and areas controlled by the valve and that it is easily read.*

### **Zone Valve Box Maintenance**

---

1. Ball valves should be operated periodically and tested for closure ability and leakage. If seals stick or leak, they should be replaced.
2. Clean the exterior of the valve boxes routinely with soap and water. Strong solvents will damage the lexan window and the silk screened printing on the window.
3. The ball valves have a removable swing out body design which allows for the changing of internal components. All valve bodies can be accessed by loosening all bolts and nuts and removing only one bolt, for valves sizes up to 2" valves, at this point the body may be swung out for servicing.

#### **⚠ WARNING**

*To protect the lives of patients, always notify the appropriate medical facility staff before shutting off the supply of medical gas or vacuum through a ball valve. Do not close ball valves except in cases of emergency. Authorized hospital should close ball valves in the event of fire, explosion or damage to the pipeline or equipment.*

## Model Numbers

1/2"	3/4"	1"	1 1/4"	1 1/2"	2"
PX-52-02	PX-52-03	PX-52-04	PX-52-05	PX-52-06	PX-52-07
PX-52-02LH	PX-52-03LH	PX-52-04LH	PX-52-05LH	PX-52-06LH	PX-52-07LH

## Removal of Seals & O-Rings

Remove and discard the worn-out seals and o-rings from Ball Valve.

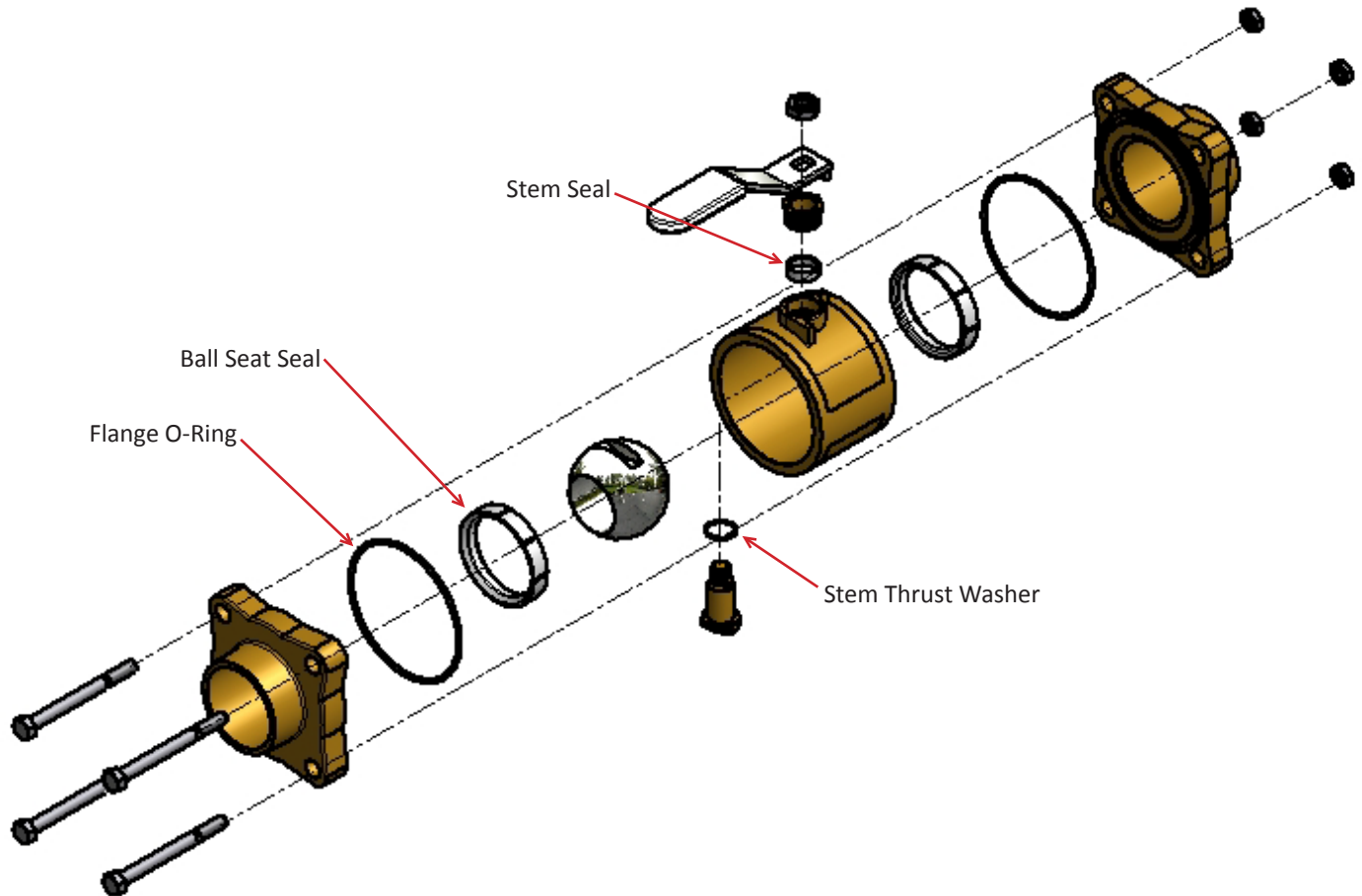

Seal Kit Part Number	Valve Size	Seal Kits Include the Following:
PX-52-0002S	1/2"	2 Ball Seat Seals 2 Flange O-Rings 1 Stem Seal 1 Stem Thrust Washer
PX-52-0003S	3/4"	
PX-52-0004S	1"	
PX-52-0005S	1 1/4"	
PX-52-0006S	1 1/2"	
PX-52-0007S	2"	

Tools Needed: Adjustable wrench; 7/16, 1/2, 9/16, 5/8, 11/16 and 11/16" Hex Wrench

## Model Numbers

1/2"	3/4"	1"	1 1/4"	1 1/2"	2"
PX-52-02	PX-52-03	PX-52-04	PX-52-05	PX-52-06	PX-52-07
PX-52-02LH	PX-52-03LH	PX-52-04LH	PX-52-05LH	PX-52-06LH	PX-52-07LH

1/2" through 2" ball valve configuration shown

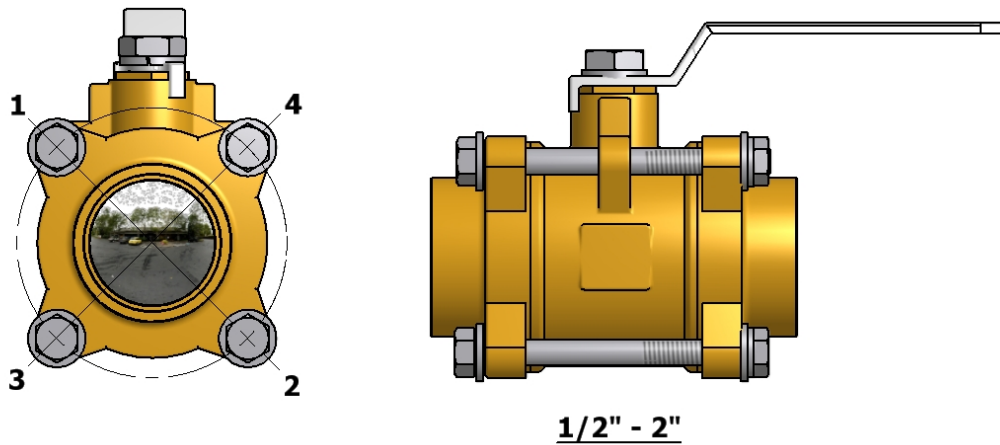

Part Number	Valve Size	Bolt Size	kgf-cm	in-lbs
PX-52-02	1/2"	1/4 - 20	75	65
PX-52-03	3/4"	5/16 - 18	86	75
PX-52-04	1"	5/16 - 18	86	75
PX-52-05	1 1/4"	3/8 - 16	144	125
PX-52-06	1 1/2"	3/8 - 16	144	125
PX-52-07	2"	7/16 - 14	230	200



Buyer's purchase order is subject to the following conditions of sale:

## **Powerex Limited Warranty**

**Warranty and Remedies. (a) Standard Period of Warranty – Parts and Labor.** Powerex warrants and represents all Products shall be free from Defects for the first twelve (12) months from the date of shipment by Powerex. During such warranty period, Powerex shall be fully liable for all Defects in the Products (the "Product Defects"), i.e., all costs of repair or replacement, which may include "in and out" charges, so long as the Products are located in the United States or Canada, and the Products are reasonably located and accessible by service personnel for removal. "In and out" charges include the costs of removing a Product from buyer's equipment for repair or replacement.

**(b) Additional Period of Warranty – Parts Only (No Labor).** In addition to the above, Powerex warrants the products described herein to be free from defects in material and workmanship for forty-eight (48) months from end of Standard Period of Warranty with the exception of any components which are recommended to be replaced in less than sixty months in our Installation/Operation manuals. Within said period Powerex will repair or replace any part or component which is proven to be defective in either material or workmanship. This warranty covers parts only. Labor is not included. This warranty is valid only when the product has been properly installed according to Powerex specifications, used in a normal manner and serviced according to factory recommendations. This warranty does not cover failures due to damage which occurs in shipment or failures which result from accidents, misuse, abuse, neglect, mishandling, alteration, misapplication or damage due to acts of nature.

**(c) General.** Powerex warrants each Powerex branded Pipeline Accessory (collectively "Products", individually each a "Product") to be free from defects in material and workmanship ("Defects") at the date of shipment. EXCEPT AS SET FORTH BELOW, NO OTHER WARRANTY, WHETHER EXPRESS OR IMPLIED, INCLUDING ANY WARRANTY OF MERCHANTABILITY OR FITNESS FOR A PARTICULAR PURPOSE, SHALL EXIST IN CONNECTION WITH THE SALE OR USE OF SUCH PRODUCTS. TO THE EXTENT PERMITTED BY LAW, ANY AND ALL IMPLIED WARRANTIES ARE EXCLUDED. All warranty claims must be made in writing and delivered to Powerex in accordance with the procedures set forth on its website ([www.powerexinc.com](http://www.powerexinc.com)), or such claim shall be barred. Upon timely receipt of a warranty claim, Powerex shall inspect the Product claimed to have a Defect, and Powerex shall replace any Product which it determines to have had a Defect; provided, however, that Powerex may elect, upon return of the Product, to refund to buyer any part of the purchase price of such Products paid to Powerex. Freight for returning Products to Powerex for inspection or for shipping warranty parts shall be paid by buyer where permitted by applicable law. Powerex is not responsible for any import fees, taxes, duties, licenses or other fees imposed by any governmental authority upon the production, sale, shipment and/or use of Products covered hereunder. The warranties and remedies herein are the sole and exclusive remedy for any breach of warranty or for any other claim based on any Defect, or non-performance of the Products, whether based upon contract, warranty or negligence.

**(d) Coverage.** The warranty provided herein applies to Powerex pipeline products only.

**(e) Exceptions.** Notwithstanding anything to the contrary herein, Powerex shall have no warranty obligations with respect to Products:

**(i)** That have not been installed in accordance with Powerex's written specifications and instructions;

**(ii)** That have not been maintained in accordance with Powerex's written instructions;

**(iii)** That have been materially modified without the prior written approval of Powerex; or

**(iv)** That experience failures resulting from operation, either intentional or otherwise, in excess of rated capacities or in an otherwise improper manner.

The warranty provided herein shall not apply to: **(i)** any defects arising from corrosion, abrasion, use of insoluble lubricants, or negligent attendance to or faulty operation of the Products; **(ii)** ordinary wear and tear of the Products; or **(iii)** defects arising from abnormal conditions of temperature, dirt or corrosive matter; **(iv)** any OEM component which is shipped by Powerex with the original manufacturer's warranty, which shall be the sole applicable warranty for such component.

**Limitation of Liability.** NOTWITHSTANDING ANYTHING TO THE CONTRARY HEREIN, TO THE EXTENT ALLOWABLE UNDER APPLICABLE LAW, UNDER NO CIRCUMSTANCES SHALL POWEREX BE LIABLE FOR ANY INCIDENTAL, CONSEQUENTIAL, PUNITIVE, SPECULATIVE OR INDIRECT LOSSES OR DAMAGES WHATSOEVER ARISING OUT OF OR IN ANY WAY RELATED TO ANY OF THE PRODUCTS OR GOODS SOLD OR AGREED TO BE SOLD BY POWEREX TO BUYER. TO THE EXTENT ALLOWABLE UNDER APPLICABLE LAW, POWEREX'S LIABILITY IN ALL EVENTS IS LIMITED TO, AND SHALL NOT EXCEED, THE PURCHASE PRICE PAID. In the event of breach of any warranty hereunder, Powerex's sole and exclusive liability shall be at its option either to repair or to replace any defective product, or to accept return, transportation prepaid, of such product and refund the purchase price; in either case provided that written notice of such defect is given to Powerex within twelve (12) months from date of shipment to Buyer, that the product is found by Powerex to have been defective at the time of such shipment, that the product has been installed and/or operated in accordance with Powerex's instructions,



that no repairs, alterations or replacements have been made by others without Powerex's written approval, and that Buyer notifies Powerex in writing within fifteen (15) days after the defect becomes apparent and promptly furnishes full particulars in connection therewith; and provided further that in no event shall the aggregate liability of Powerex in connection with breach of any warranty or warranties exceed the purchase price paid for the product purchased hereunder. Powerex may, at its option, require the return of any product, transportation and duties prepaid, to establish any claim of defect made by Buyer. Unless otherwise agreed in writing **(a)** Powerex will not accept and shall have no responsibility for products returned without its prior written consent, and **(b)** Powerex will not assume any expense or liability for repairs to products made outside of its plant by third parties. In the event Powerex elects to replace a defective product, costs of installation, labor, service, and all other costs to replace the product shall be the responsibility of Buyer.

Powerex shall not, except as set forth above, be otherwise liable to Buyer or to any person who shall purchase from Buyer, or use, any products supplied hereunder for damages of any kind, including, but not limited to, indirect, special or consequential damages or loss of production or loss of profits resulting from any cause whatsoever, including, but not limited to, any delay, act, error or omission of Powerex. Supplier's repair or replacement of any Product shall not extend the period of any warranty of any Product.

**Warranty Disclaimer.** Powerex has made a diligent effort to illustrate and describe the Products in its literature, including its Price Book, accurately; however, such illustrations and descriptions are for the sole purpose of identification, and do not express or imply a warranty that the Products are merchantable, or fit for a particular purpose, or that the Products will necessarily conform to the illustrations or descriptions.

**Product Suitability.** Many jurisdictions have codes and regulations governing sales, construction, installation, and/or use of Products for certain purposes, which may vary from those in neighboring areas. While Powerex attempts to assure that its Products comply with such codes, it cannot guarantee compliance, and cannot be responsible for how the product is installed or used. Before purchase and use of a Product, please review the Product applications, and national and local codes and regulations, and be sure that the Product, installation, and use will comply with them.

**Claims.** Any non-warranty claims pertaining to the Products must be filed with Powerex within (6) months of the invoice date, or they will not be honored. Prices, discounts, and terms are subject to change without notice or as stipulated in specific Product quotations. Powerex shall not be liable for any delay or failure arising out of acts of the public enemy, fire, flood, or any disaster, labor trouble, riot or disorder, delay in the supply of materials or any other cause, whether similar or dissimilar, beyond the control of Company. All shipments are carefully inspected and counted before leaving the factory. Please inspect carefully any receipt of Products noting any discrepancy or damage on the carrier's freight bill at the time of delivery. Discrepancies or damage which obviously occurred in transit are the carrier's responsibility and related claims should be made promptly directly to the carrier. Returned Products will not be accepted without prior written authorization by Powerex and deductions from invoices for shortage or damage claims will not be allowed. **UNLESS OTHERWISE AGREED TO IN WRITING, THE TERMS AND CONDITIONS CONTAINED IN THIS LIMITED WARRANTY WILL CONTROL IN ANY TRANSACTION WITH POWEREX.** Any different or conflicting terms as may appear on any order form now or later submitted by the buyer will not control. All orders are subject to acceptance by Powerex.