

### Submittal Data Sheet

#### Features

The Powerex Area Alarm Panel conversion kits are designed to upgrade or retro-fit existing panels produced by several major brands. The conversion kit replaces all necessary major components re-utilizing the existing back box.

The Powerex Med Touch Area Alarm Panel digitally displays gas pressure (1 psi increments) and provides alarm conditions as required by the latest edition of NFPA 99 for up to 16 medical gases. Transducers are included. DISS riser adapters are included where applicable. Transducers may be installed remotely or in back box.

- Individual 2.85" LCD touch screen display for each gas service
- The LCD touch screen allows all alarm programming and set up to be done without the use of tools
- A green normal or red alarm condition for each gas service confirms the condition for each individual gas service
- Emergency preparedness instructions - Med Touch Alarm Panels allow users to set up customized instructions for each alarm signal which appear when the signal is in alarm
- Up to 4 area/gas boards in a two slot box, 8 in a three slot and 16 in a five slot panel
- Last event history (per gas board /signal point)
- Made in the U.S.A.
- NFPA and ISO pre-loaded gas 'labels'
- English, and English/French pre-loaded languages
- Editable text and alarm 'labels'
- Self-contained unit designed for ease of installation & service
- Self-diagnostic error message display for ease of maintenance
- Audio and visual alarm indicators
- Bright easy to read LCD displays – clearly visible in both day and night lighting conditions
- Constant display and monitoring of each gas
- User programmable high/low set points
- Dry contacts for remote monitoring of all alarm conditions on each gas module and on the CPU module for the entire panel
- Hinged frame for easy accessibility
- Color coded displays
- Does not require re-calibration
- Gas specific sensor with DISS nut & nipple. An error message will be displayed if incorrect sensor or no sensor is attached
- Shall be capable of displaying gas readouts in PSI, kPa, BAR, inHg, or mmHg
- Gas alarm repeat feature is factory set at 10 minutes, and is adjustable or may be turned off

#### Specifications

The alarm shall be the Powerex Med Touch Area Alarm. The panel shall be microprocessor controlled and designed to comply with NFPA 99. The panel shall incorporate an individual 2.85" LCD touch screen display for each gas service which shall allow all alarm programming and set up to be done without the use of tools. The panel shall be 100% digital and shall not require re-calibration. The unit shall be designed



to accept an electrical input range of 120-240 volts AC – 50-60 hertz. The source voltage shall be stepped down with a self-contained transformer. The panel shall contain audible and visual alarm indicators. The audible alarm may be silenced by pressing the alarm silence button, but the visual alarm indicator can only be cancelled by fault correction. The alarm shall detect and filter out transient (less than 0.6 seconds) signals created by R.F.I. The alarm shall be capable of displaying alarm history for all possible alarm conditions. The alarm shall be capable of monitoring and displaying up to 16 gases per alarm panel. Gas modules can be arranged in accordance with the customer's requirements. A security pin code shall be required and must be entered in order to access the programming software.

The following options shall be able to be added to the panel at the time of order or after installation;

- Optional Text / e mail notification of alarm events sent to up to five addresses.
- Optional Ethernet module. This module may be added to any alarm panel. It will provide the following features:
  - Webserver – allows a remote user access to the alarm's webpage – viewing a graphic image of the alarm with all signal conditions, pressure & event / history log information.
  - Text notification of alarm conditions (up to 5 addresses).
  - Event / history log – maintains a rolling list of the 100 most recent alarm condition events and a file of the 1,000 most recent alarm events and is downloadable through embedded web page.
  - Modbus interface.
- Event log is viewable and downloadable through embedded web page, including the most recent 1,000 events.
- Optional Ethernet connectivity with embedded web page.
- Interface with building automation system via Ethernet.

### Gas/Area Display

Shown in alarm condition displaying rooms/area monitored. Display blinks on and off when in alarm condition drawing attention and alternates displaying rooms/area monitored with user programmed emergency instructions.



Shown in alarm condition displaying emergency instructions. Display blinks on and off when in alarm condition drawing attention and alternates displaying rooms/area monitored with user programmed emergency instructions.



Shown in normal condition. Code specific gas colors, and gas name are displayed at the top in facilities language. Gas pressure and units of measure are displayed in the middle of the screen. Normal or Alarm condition is displayed in the bottom center. Rooms/area monitored alternates with user programmed emergency instructions at the bottom.



Easy to use icon menu provides quick access to programming options.

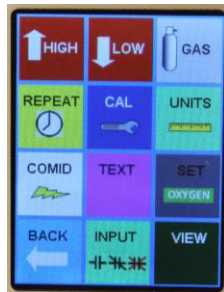

Security is built in to each circuit board. The correct four digit pin code must be entered in order to access the programming software.

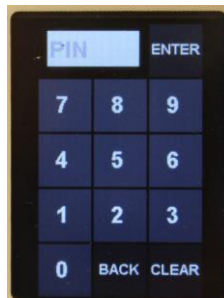

**Ordering Information**

Easy to use modular ordering system.

Fill in the blanks to specify the Med Touch Area Alarm that meets your needs.

**Model Numbering:**

PX-	T	N	C	Y	G	G	G	G	G	G	G	G	G	G	G	G	G	G
-----	---	---	---	---	---	---	---	---	---	---	---	---	---	---	---	---	---	---



**NOTE:** A 35-3032 kit may be ordered separately and installed in the field to provide; Ethernet webserver, event log, alarm notifications may be sent up to 5 users via text or e-mail and Modbus Interface. The 35-3033 Ethernet programming kit is required and must be ordered when the 35-3032 kit is ordered. Only one is needed per facility.

**G = Gas Service**

- |  |  |                           |
|--|--|---------------------------|
| <b>A</b> = Medical Air   | <b>H</b> = Hyperbaric Oxygen   | <b>N</b> = Nitrous Oxide  |
| <b>B</b> = Blank Slot<br>4 Vertical Future<br>Expansion (Blank)<br>Positions in One Slot | <b>I</b> = Instrument Air  | <b>O</b> = Oxygen         |
| <b>C</b> = Carbon Dioxide 50psig   | <b>J</b> = CO <sub>2</sub> -O <sub>2</sub> Mixtures<br>CO <sub>2</sub> over 7% DISS 1080 | <b>R</b> = Tri-Gas        |
| <b>D</b> = Carbon Dioxide 80psig   | <b>K</b> = He-O <sub>2</sub> Mixtures<br>He over 80% DISS 1060                           | <b>S</b> = AGSS           |
| <b>F</b> = Future Expansion  | <b>L</b> = Helium  | <b>T</b> = Nitrogen       |
|  |  | <b>V</b> = Medical Vacuum |
|  |  | <b>W</b> = WAGD/EVAC      |

**Y = Conversion Type**

- |                            |   |                       |                          |
|----------------------------|---|-----------------------|--------------------------|
| <b>2</b> – Amico           | <b>4</b> – Chemetron                                | <b>6</b> – Powerex AA | <b>7</b> – Ohio & Medaes |
| <b>8</b> – Powerex AU & DU | <b>9</b> – Beacon Medaes Mega 2, Mega 3, & Infinity |                       |                          |

**C = Gas Set**

- |  |  |
|--|--|
| <b>U</b> – Powerex Labeled NFPA Color Code English | <b>I</b> – Powerex Labeled ISO Color Code English/French |
|--|--|

**N = Number of Slots on Front Panel**

- |                               |                               |                               |
|-------------------------------|-------------------------------|-------------------------------|
| <b>2</b> – 2 Slot Front Panel | <b>3</b> – 3 Slot Front Panel | <b>5</b> – 5 Slot Front Panel |
|-------------------------------|-------------------------------|-------------------------------|

**T = Type of Alarm**

- |                                 |
|---------------------------------|
| <b>T</b> – Touch Screen Digital |
|---------------------------------|

Part Number Examples

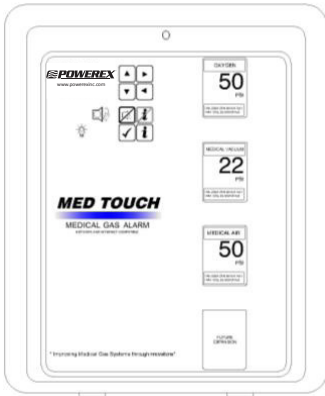

**PX-T2U80VAF** = Converts Powerex AU or DU series 2 Slot Area Alarm, set for NFPA Color Code English. Gas set Oxygen, Medical Vacuum, Medical Air gas modules in 2nd slot. Last module in 2nd slot is for Future Expansion (Blank). No Interface Communication Option.

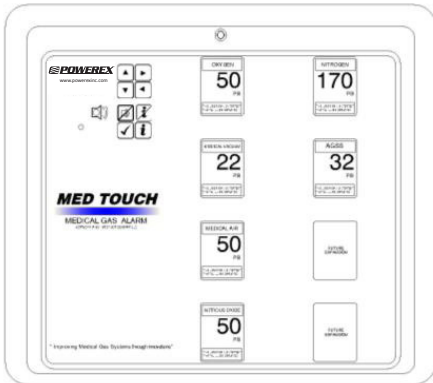

**PX-T3U20VANTWFF2** = Converts Amico 6 Gas Area Alarm, 3 Slot set for NFPA Color Code English. Gas set Oxygen, Medical Vacuum, Medical Air and Nitrous Oxide in 2nd slot, Nitrogen, WAGD and two Future Expansion (Blank) modules in 3rd slot. Ethernet Web Server and Modbus Interface Communication Option.

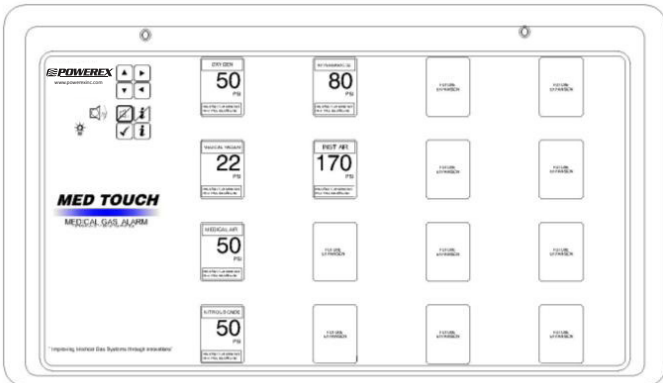

**PX-T5U70VANHIFFBB2** = Converts Ohio Medical 6 Gas Area Alarm, 5 Slot set for NFPA Color Code English. Gas set Oxygen, Medical Vacuum, Medical Air and Nitrous Oxide in 2nd slot, Hyperbaric Oxygen, Instrument Air and two Future Expansion (Blank) positions in 3rd slot (Slots 4 and 5 are Blank). Ethernet Web Server and Modbus Interface. Communication Option.

### Dimensions

Inches (mm)

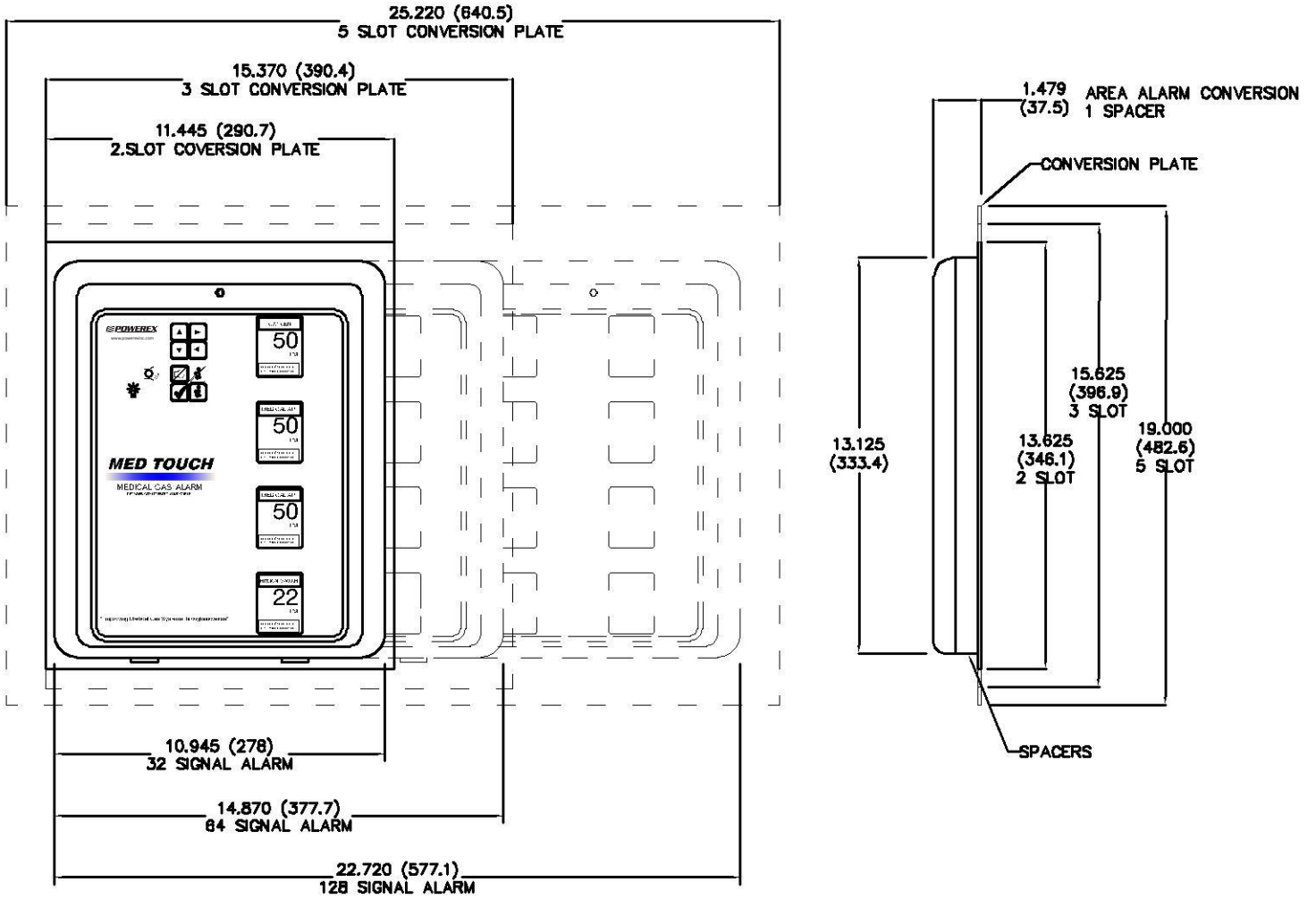

### Typical Methods of Remotely Mounting Transducers

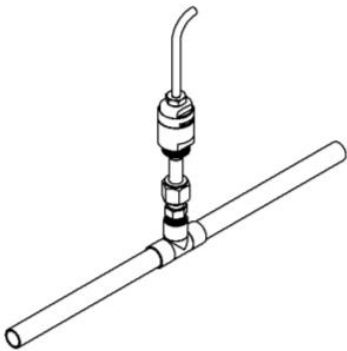

On piping using a "Tee" and Gas Specific Demand Valve

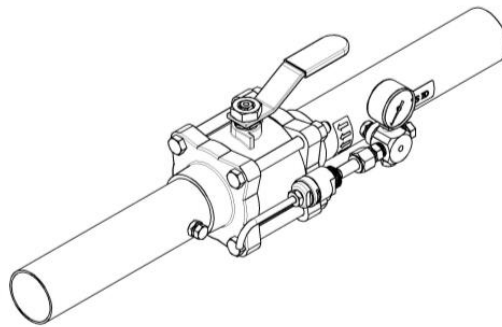

On Zone Valve using Powerex EZ Find Valves or Retrofit Kits

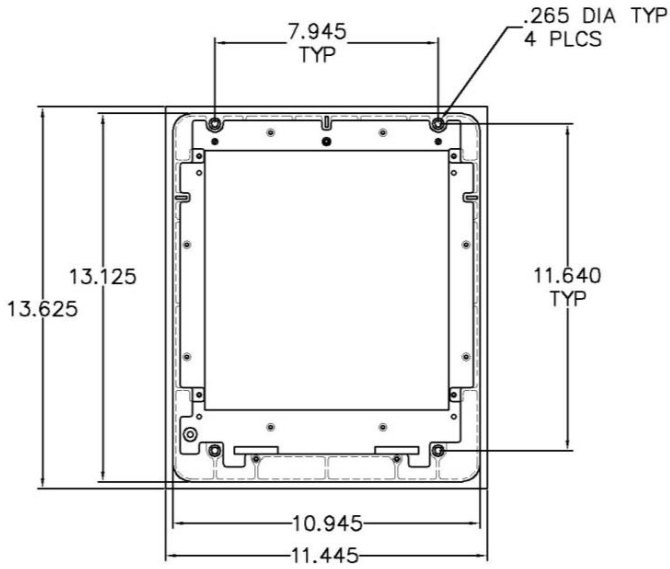

2 Slot Alarm Front Conversion Sub-Mounting Plate

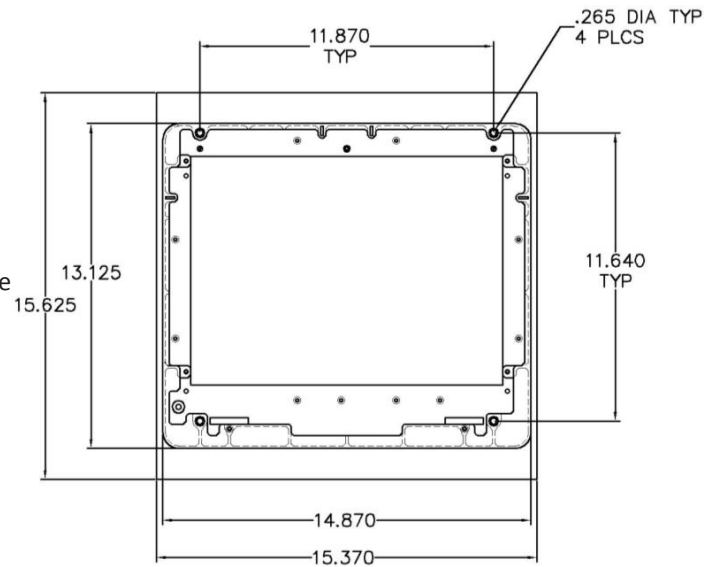

3 Slot Alarm Front Conversion Sub-Mounting Plate

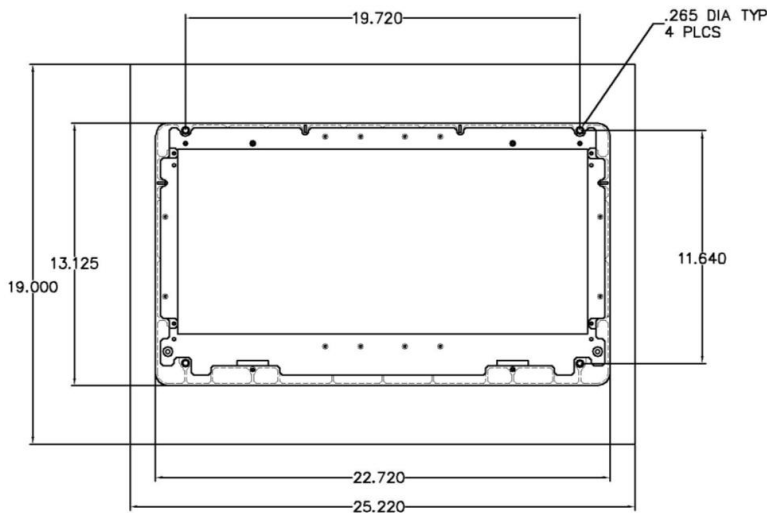

5 Slot Alarm Front Conversion Sub-Mounting Plate