

UTILITY REQUIREMENTS

MODEL	PRESSURE	NAMEPLATE HORSEPOWER	COOLING FAN OUTPUT CFM	HEAT REJECTION TO AIR BTU/MIN	APPROX. POWER CONSUMPTION kW	APPROX. SHIPPING WEIGHT LB
A/H	125 PSIG (OPERATING)	50	6500	2350	45	3670
	150 PSIG (MAX WORKING)		6500	2620	50	
B/L	100 PSIG (OPERATING)	50	6500	2590	49	3670
	125 PSIG (OPERATING)		6500	2900	55	
B/H	125 PSIG (OPERATING)	60	6500	3210	60	3740
	150 PSIG (MAX WORKING)		6500	3160	59	
C/L	100 PSIG (OPERATING)	60	6500	3540	66	3740
	125 PSIG (OPERATING)		6500	3940	73	
C/H	125 PSIG (OPERATING)	75	6500	3580	67	3880
	150 PSIG (MAX WORKING)		6500	4020	74	
D/L	100 PSIG (OPERATING)	75	6500	4200	77	3910
	125 PSIG (OPERATING)		6500	4200	77	
D/H	125 PSIG (OPERATING)	100	6500	4420	81	3910
	135 PSIG (MAX WORKING)		6500	4420	81	
E/L	100 PSIG (OPERATING)	100	6500	4420	81	3910

ELECTRICAL REQUIREMENTS: 3Ø, 60Hz, 480V

- NOTES**
 1. PERFORMANCE DATA SHOWN IS FOR STANDARD CONDITIONS OF AMBIENT PRESSURE 14.5 PSIA, AMBIENT TEMPERATURE 80°F, RELATIVE HUMIDITY 60%. OPERATION IN OTHER CONDITIONS WILL AFFECT PERFORMANCE.
 2. VALUES WILL VARY ±4% FOR CAPACITY AND ±5% FOR SPECIFIC POWER.

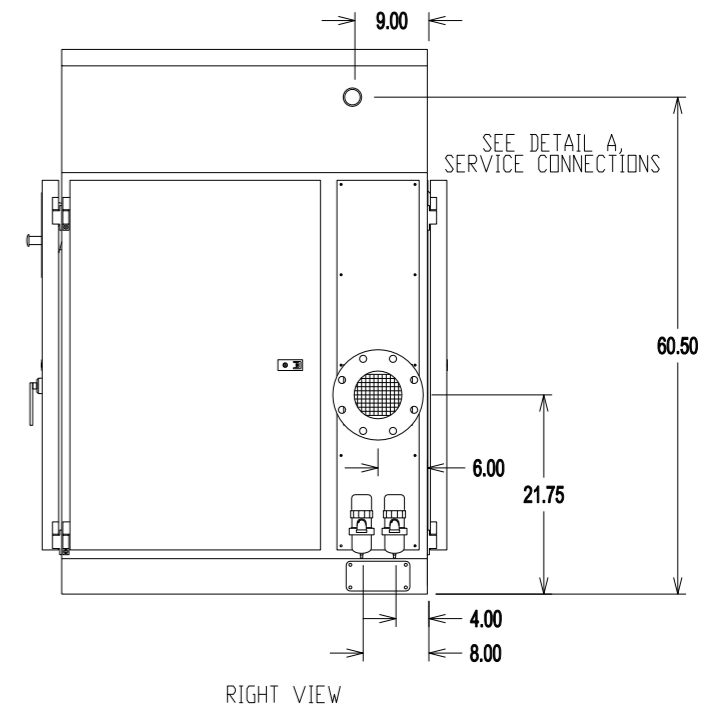
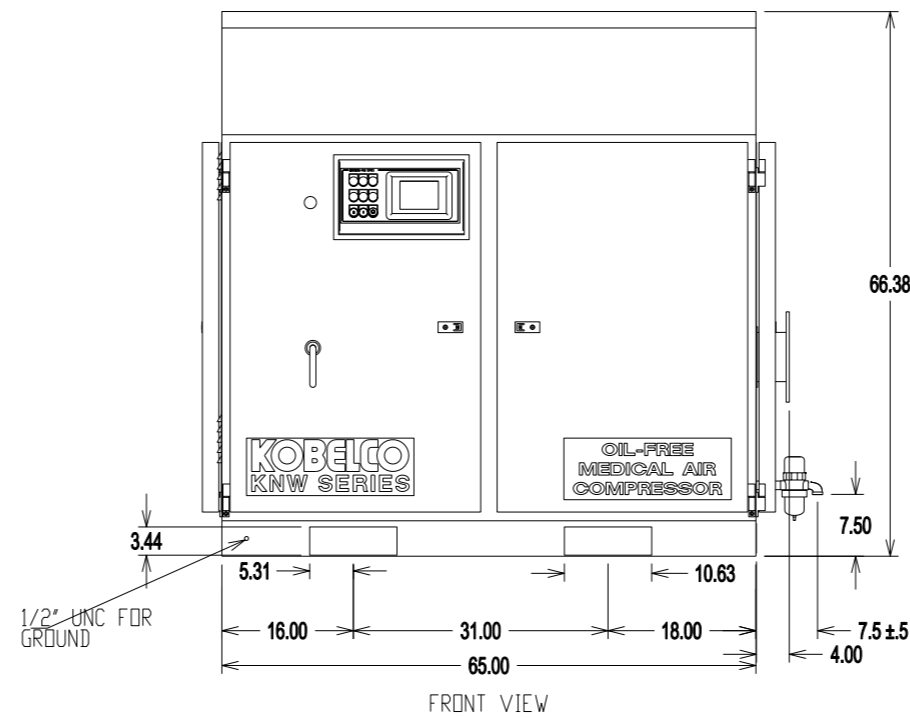
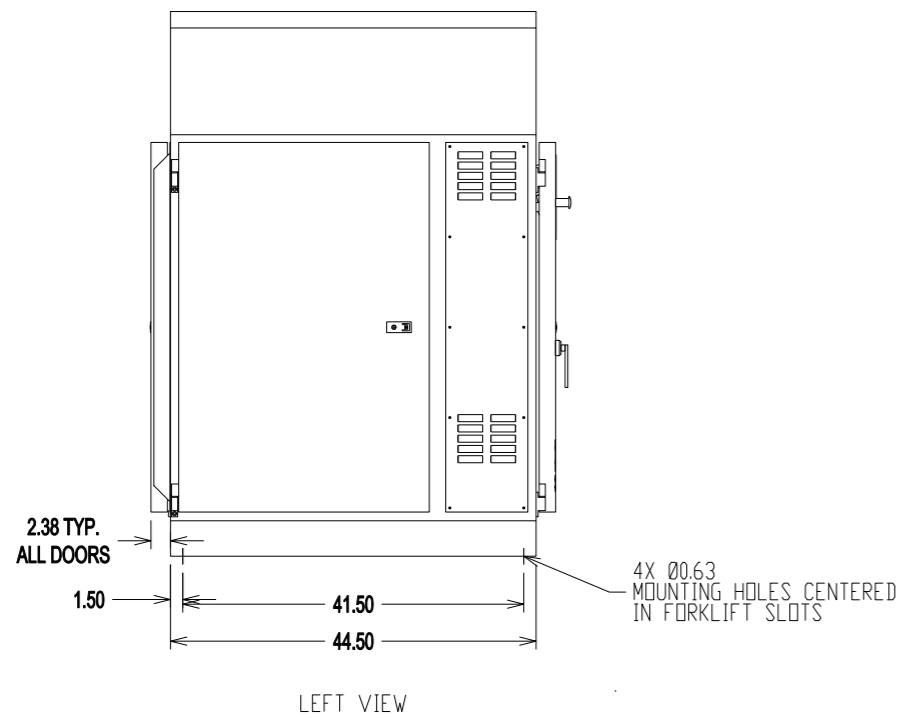
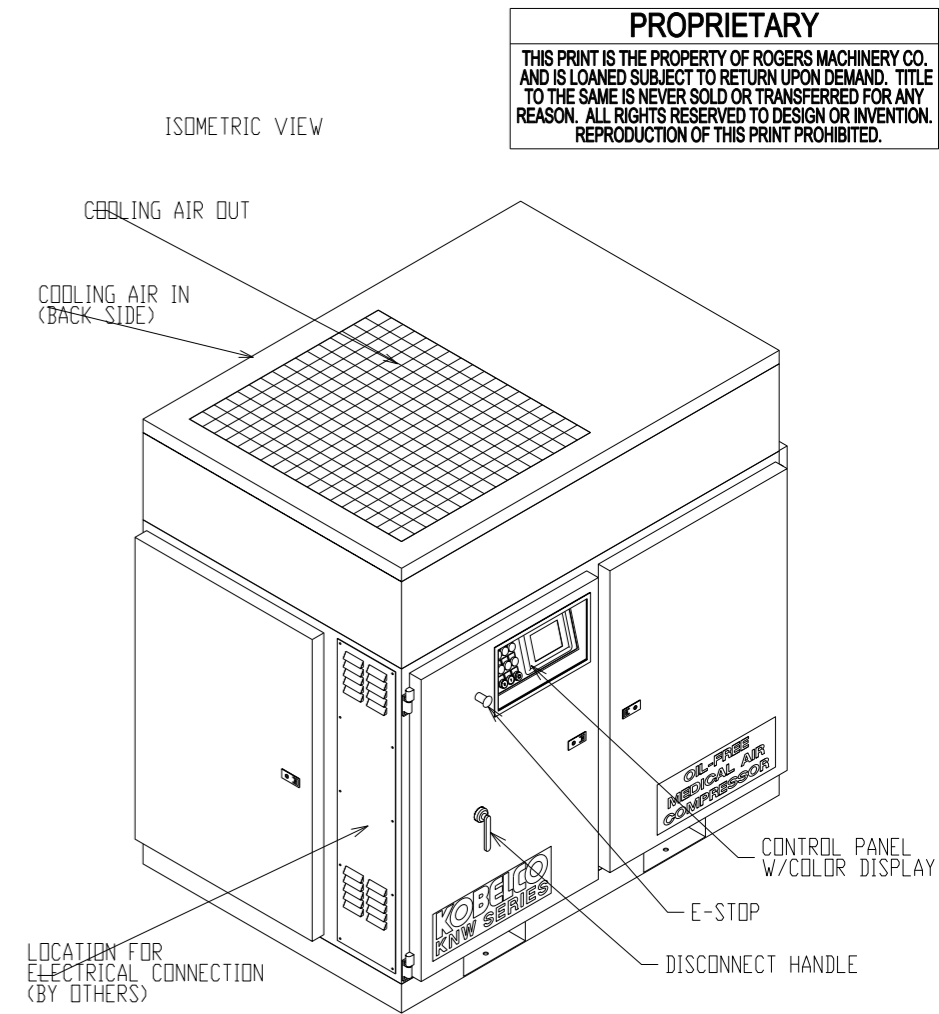
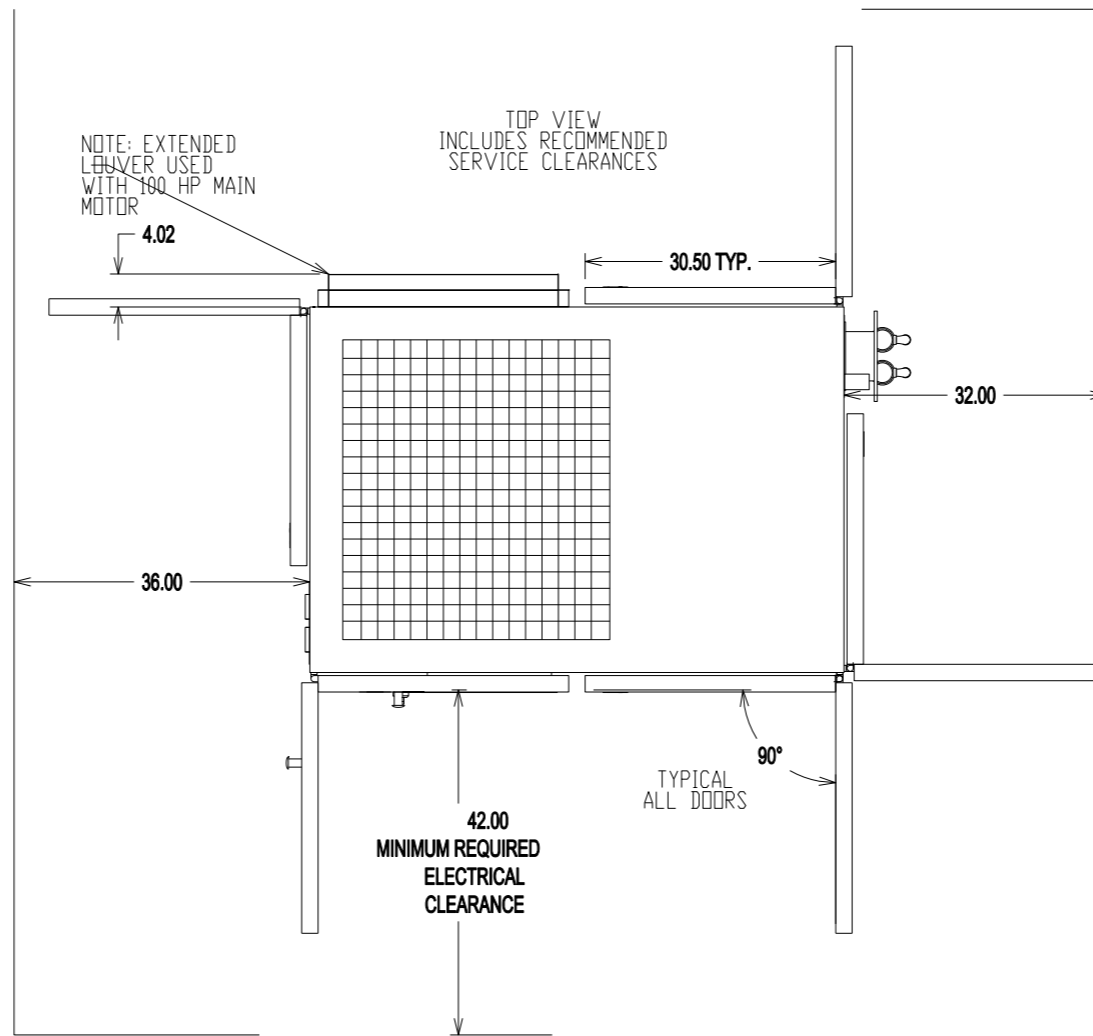
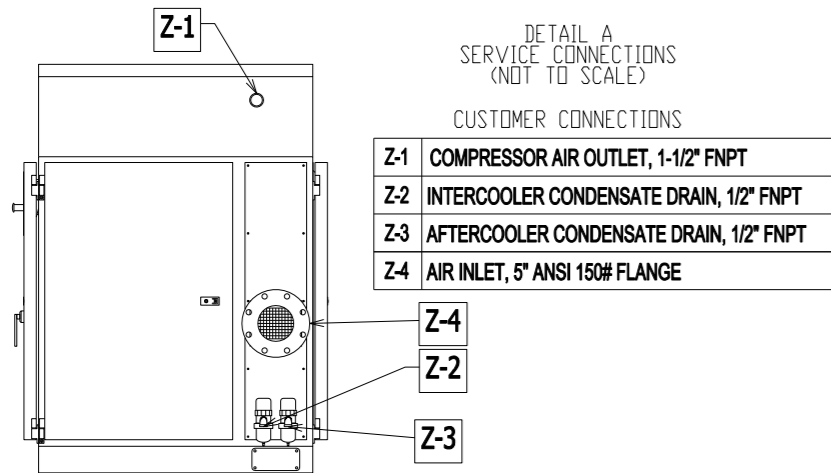

DIMENSIONS ARE IN INCHES UNLESS OTHERWISE NOTED

ROGERS MACHINERY COMPANY, INC.
 CORPORATE ENGINEERING
 14650 S.W. 72ND AVENUE
 PORTLAND, OREGON 97224
 www.rogers-machinery.com

REV	DATE	BY	CK	DESCRIPTION

DRAWN	G.E. WILKER	05DEC13
CHECKED		
SIZE	B	SCALE 1:24
SERIAL#	POWEREX - TBD	

COMPRESSOR ASSEMBLY
 KOBELCO KNW SERIES AIR COMPRESSOR
 MODEL KNWA0, AIR-COOLED
 WYE-DELTA STARTER, NFPA99 HEALTHCARE

DRAWING NUMBER
K00756A.0
 SHEET 1 OF 1

GALLONS	SIZE	DESIGN PRESSURE	WEIGHT lbs.	DESCRIPTION
400	36 x 101	165 PSI	880	ASME VERTICAL INDUSTRIAL w/BASE RING

REV	ZONE	REVISION	DATE	ECN	NAME	CHWD
A-1	ALL	SUBMITTAL DRAWINGS	8/7/13	PKEC0092	RK	AEK
B-1	ALL	RELEASE FOR PRODUCTION	8/7/13	PKEC0092	RK	AEK
C-1	ALL	CHANGED TANK PSI FROM 200 TO 165	04/26/18	PKEC0229	DMS	GES

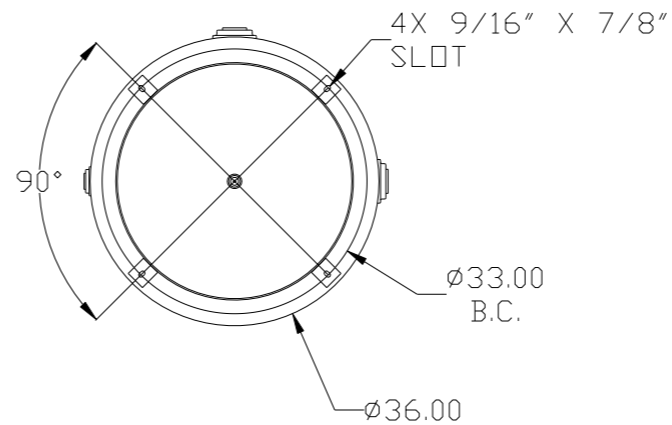
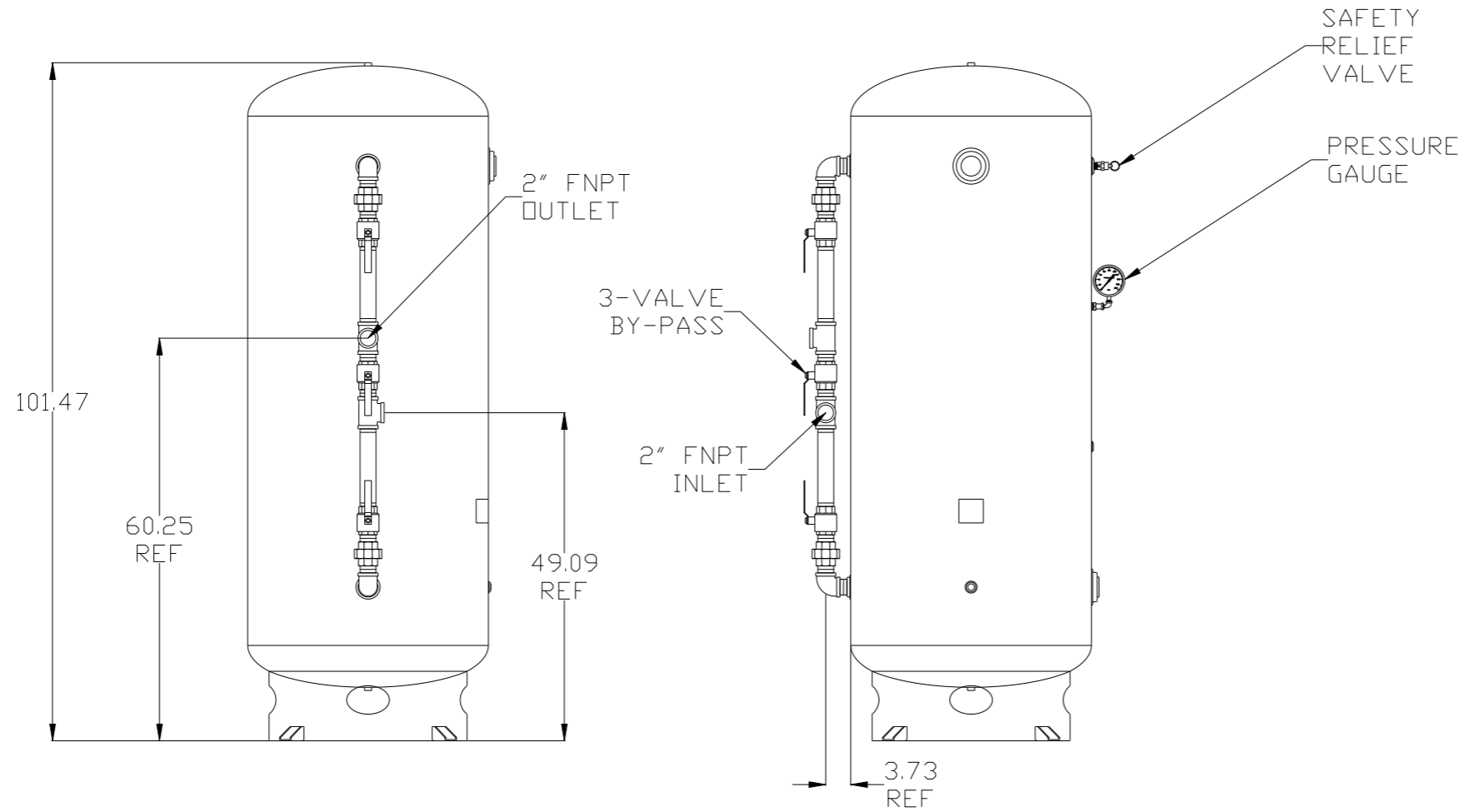

NOTES:
 1) ASME CERTIFIED VESSEL
 2) ALL DIMENSIONS ARE REFERENCE DIMENSIONS
 3) APPROXIMATE WT. - 880 LBS.

SYMBOL LEGEND		= ADDITIONAL CONTROL REQ'D		Drawings to conform to the current revision of the following ANSI standards:	
⊖	MINUS DRAFT	⊕	PLUS DRAFT	⊖	BRINELL HARDNESS
TOLERANCES NOT SPECIFIED		AUTOCAD REL2008 LT		DO NOT SCALE DRAWING FOR DIMENSIONS	
.XX	±	INCH		Sheet 2 of 5	
.XXX	±			SCALE 1:12	
<<DEG>>	±				
CONFIDENTIAL DISCLOSURE: This drawing is the property of POWEREX, INC. of the SCOTT FETZER COMPANY and subject to return on demand. Its contents are confidential and must not be copied or submitted to outside parties for use or examination.					
DRAWN BY		CHECKED BY		APPROVED BY	
RK		AEK		JA CT	
8/6/13		8/7/13		8/7/12 8/7/12	
MATERIAL: N/A					
PART NAME: 40-100HP VFD TRIPLEX ENCLOSED COMPRESSOR					
400 GALLON DUAL DESICCANT PACKAGE					
DWG NO: LDRE1007				SIZE: D	

REV	ZONE	REVISION	DATE	ECN	NAME	CHKD
A-1	ALL	SUBMITTAL DRAWINGS	8/7/13	PXEC0052	RK	AEK
B-1	ALL	RELEASE FOR PRODUCTION	8/7/13	PXEC0052	RK	AEK
C-1	ALL	CHANGED TANK PSI FROM 200 TO 165	04/26/18	PXEC0029	DMS	GES

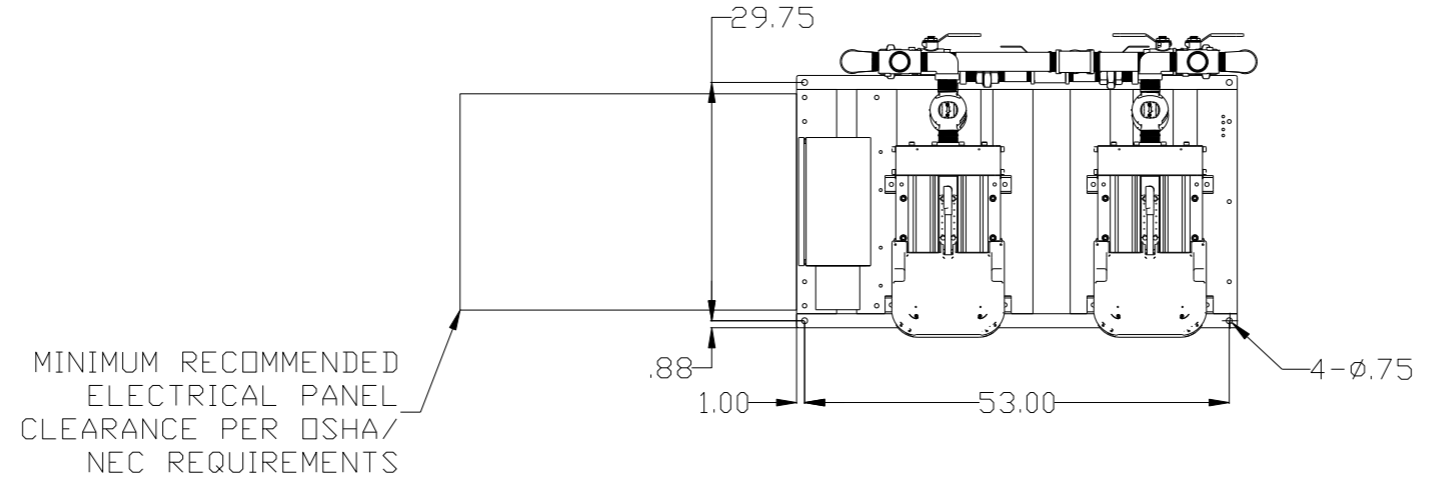

2X DESICCANT AIR DRYER
W/ PRE-FILTER, AFTER-FILTER,
& CHARCOAL FILTER (OPTIONAL).

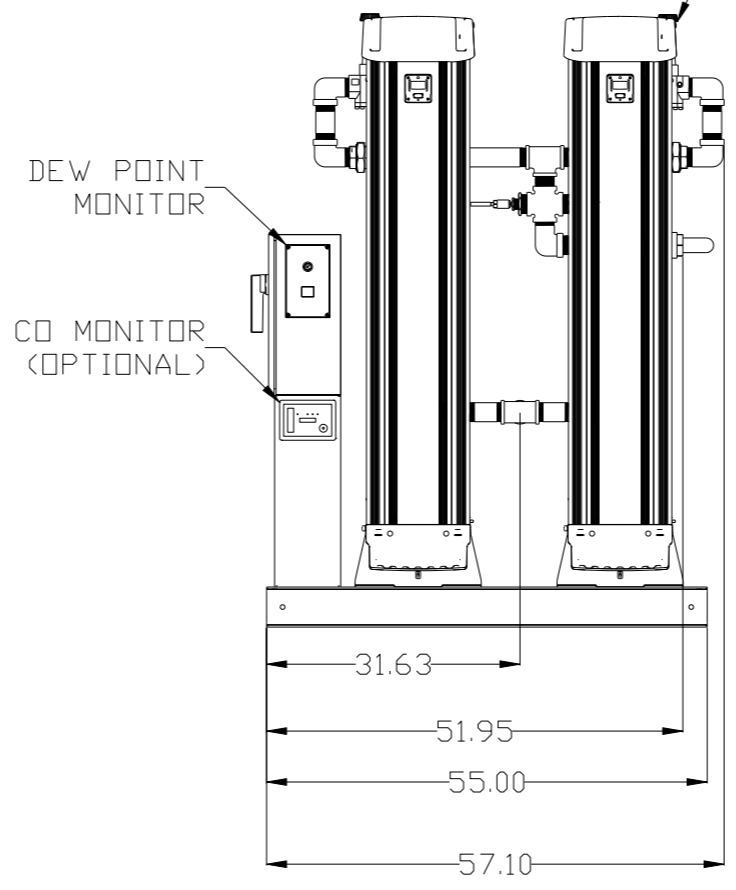
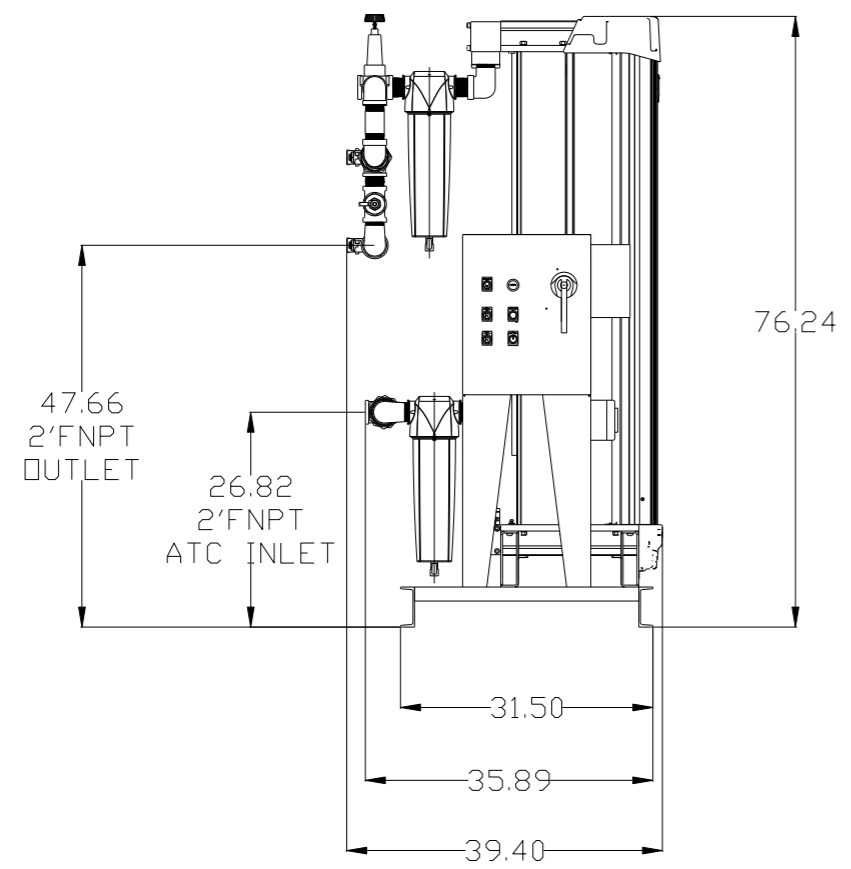

SYMBOL LEGEND ⊖ = MINUS DRAFT ⊕ = PLUS DRAFT XX ± .XXX ± <DEG> ±		= ADDITIONAL CONTROL REQ'D = BRINELL HARDNESS		Drawings to conform to the current revision of the following ANSI standards: Y14.3 Multi and sectional view dgs. Y14.5M Dimensioning and tolerancing	
TOLERANCES NOT SPECIFIED AUTOCAD REL2008 LT INCH		DO NOT SCALE DRAWING FOR DIMENSIONS Sheet 3 of 5 SCALE 1: 12		CONFIDENTIAL DISCLOSURE This drawing is the property of POWEREX, INC. of the SCDT FETZER COMPANY and subject to return on demand. Its contents are confidential and must not be copied or submitted to outside parties for use or examination.	
DRAWN BY RK 8/6/13		CHECKED BY AEK 8/7/13		APPROVED BY ENGINEERING JA 8/7/12 MFG/MRKTG CT 8/7/12	
MATERIAL N/A				150 PRODUCTION DRIVE, HARRISON, OHIO 45030 Ph: 888-769-7979 FAX: (513) 367-3125	
PART NAME DRYER PACKAGE SKID		DWG NO LDRE1007		SIZE D	
55" x 31.5"					

REV	ZONE	REVISION	DATE	ECN	NAME	CHKD
A-1	ALL	SUBMITTAL DRAWINGS	8/7/13	PXC0052	RK	AEK
B-1	ALL	RELEASE FOR PRODUCTION	8/7/13	PXC0052	RK	AEK
C-1	ALL	CHANGED TANK PSI FROM 200 TO 165	04/26/18	PXC0029	DMS	GES

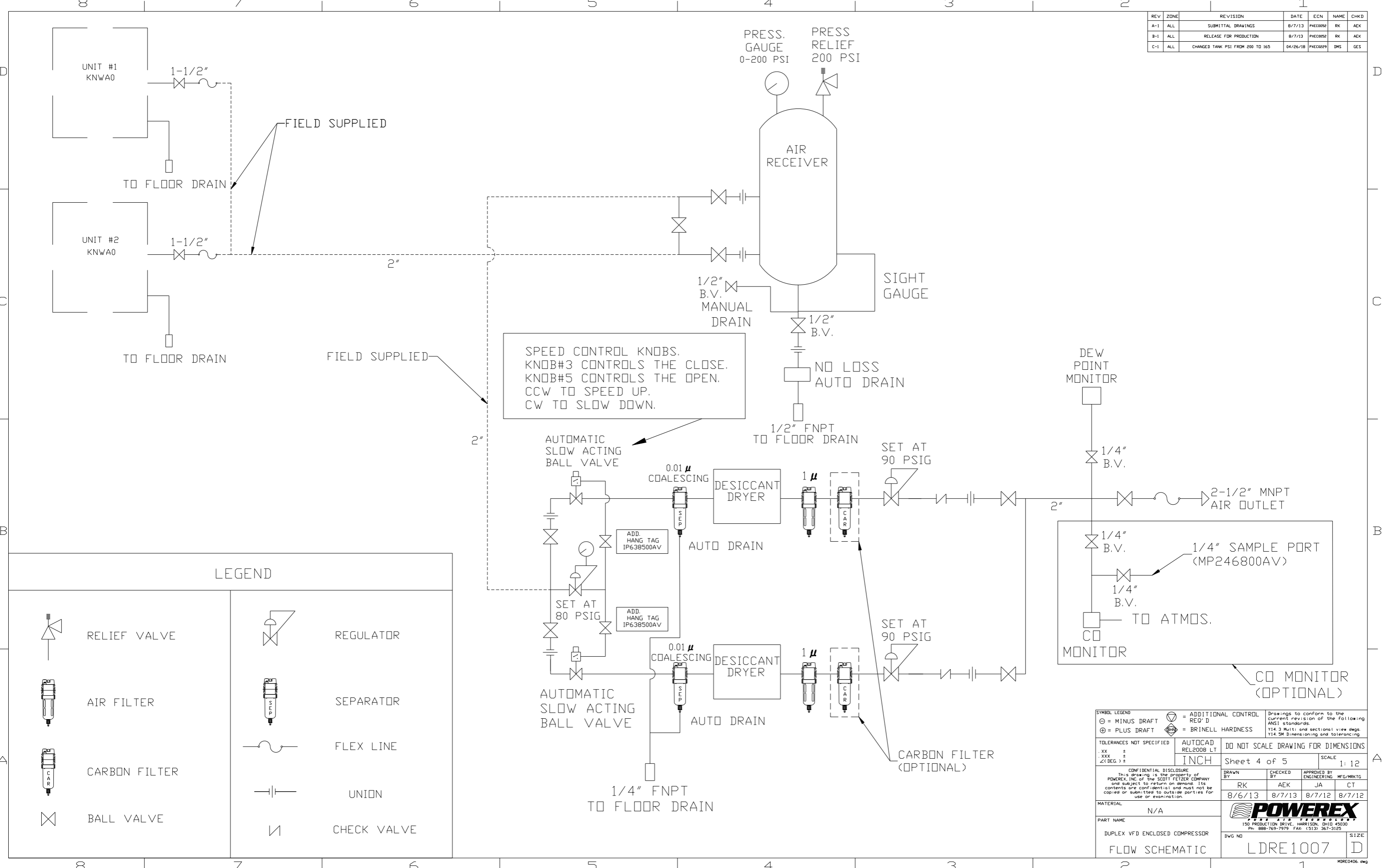

SPEED CONTROL KNOBS.
 KNOB#3 CONTROLS THE CLOSE.
 KNOB#5 CONTROLS THE OPEN.
 CCW TO SPEED UP.
 CW TO SLOW DOWN.

LEGEND	
	RELIEF VALVE
	AIR FILTER
	CARBON FILTER
	BALL VALVE
	REGULATOR
	SEPARATOR
	FLEX LINE
	UNION
	CHECK VALVE

DEW POINT MONITOR

1/4" B.V.

2-1/2" MNPT AIR OUTLET

1/4" B.V.

1/4" B.V.

1/4" SAMPLE PORT (MP246800AV)

TO ATMOS.

CO MONITOR (OPTIONAL)

SYMBOL LEGEND		= ADDITIONAL CONTROL REQ'D		Drawings to conform to the current revision of the following ANSI standards.	
= MINUS DRAFT		= BRINELL HARDNESS		Y14.3 Multi and sectional view dgs. Y14.5M Dimensioning and tolerancing	
= PLUS DRAFT					
TOLERANCES NOT SPECIFIED		AUTOCAD REL2008 LT		DO NOT SCALE DRAWING FOR DIMENSIONS	
.XX ±		INCH		Sheet 4 of 5	
.XXX ±				SCALE 1:12	
∠(DEG.) ±					
CONFIDENTIAL DISCLOSURE This drawing is the property of POWEREX, INC. of the SCOTT FETZER COMPANY and subject to return on demand. Its contents are confidential and must not be copied or submitted to outside parties for use or examination.					
DRAWN BY		CHECKED BY		APPROVED BY	
RK		AEK		JA CT	
8/6/13		8/7/13		8/7/12 8/7/12	
MATERIAL		N/A		POWEREX	
PART NAME		DUPLEX VFD ENCLOSED COMPRESSOR		150 PRODUCTION DRIVE, HARRISON, OHIO 45030 Ph: 888-769-7979 FAX: (513) 367-3125	
FLOW SCHEMATIC		DWG NO		L DRE1007	
				SIZE D	

REV	ZONE	REVISION	DATE	ECN	NAME	CHKD
A-1	ALL	SUBMITTAL DRAWINGS	8/7/13	PXEC0052	RK	AEK
B-1	ALL	RELEASE FOR PRODUCTION	8/7/13	PXEC0052	RK	AEK
C-1	ALL	CHANGED TANK PSI FROM 200 TO 165	04/26/18	PXEC0029	DMS	GES

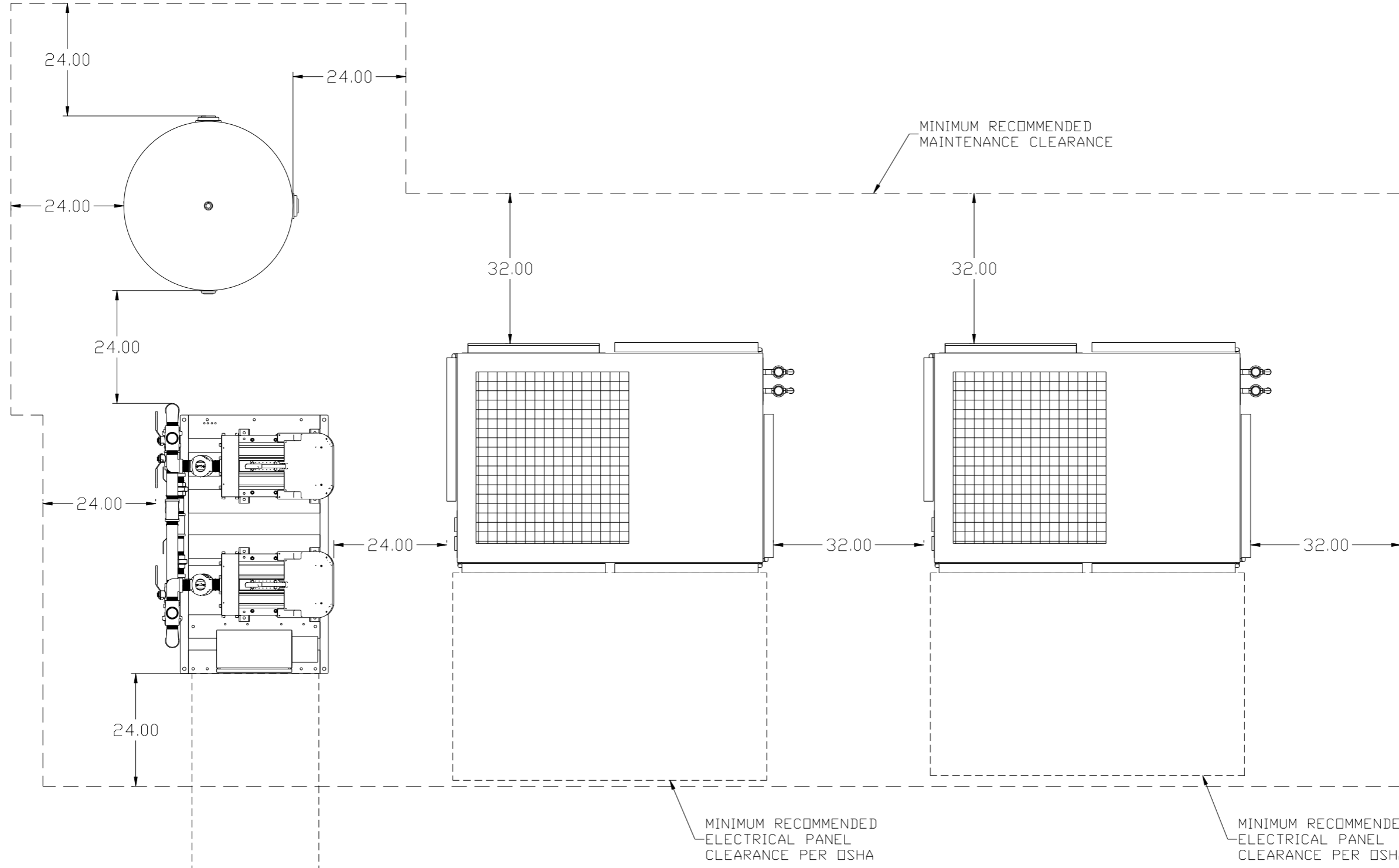

MINIMUM RECOMMENDED ELECTRICAL PANEL CLEARANCE PER OSHA/NEC REQUIREMENTS

MINIMUM RECOMMENDED ELECTRICAL PANEL CLEARANCE PER OSHA

MINIMUM RECOMMENDED ELECTRICAL PANEL CLEARANCE PER OSHA

SYMBOL LEGEND		= ADDITIONAL CONTROL REG'D		Drawings to conform to the current revision of the following ANSI standards:	
⊖	= MINUS DRAFT	⊕	= PLUS DRAFT	⊖	= BRINELL HARDNESS
TOLERANCES NOT SPECIFIED		AUTOCAD REL2008 LT		DO NOT SCALE DRAWING FOR DIMENSIONS	
.XX ±		INCH		Sheet 5 of 5	
.XXX ±				SCALE 1:12	
∠ DEG. ±					
CONFIDENTIAL DISCLOSURE		DRAWN BY		CHECKED BY	
This drawing is the property of POWEREX, INC. of the SCOTT FETZER COMPANY and subject to return on demand. Its contents are confidential and must not be copied or submitted to outside parties for use or examination.		RK		AEK	
		8/6/13		8/7/13	
				APPROVED BY	
				JA	
				CT	
				8/7/12	
MATERIAL		N/A			
PART NAME		40-100HP VFD DPLEX ENCLOSED COMPRESSOR			
DWG NO		INSTALLATION			
SIZE		LDRE1007		D	