

Introduction

Powerex PX-RWP systems are designed for level I and level II installations requiring a permanent back-up or emergency reserve system. They provide an on-line storage of gas as well as higher flow rates than may be achieved by using a single cylinder. All systems are cleaned for use with oxygen in accordance with CGA G4.1, tested and built in accordance to Compressed Gas Association (CGA) and National Fire Protection Association (NFPA 99) guidelines.

General Instructions/Location & Shelter

Manifolds should be installed in accordance with guidelines stated by the National Fire Protection Association, the Compressed Gas Association, OSHA, and all applicable local codes. Carbon Dioxide and Nitrous Oxide manifolds and cylinders should not be placed in a location where the temperature will exceed 120°F (49°C) or fall below 20°F (-7°C). The manifolds for all other gas services should not be placed in a location where the temperature will exceed 120°F (49°C) or fall below 0°F (-18°C). A manifold placed in an open location should be protected against weather conditions. During winter, protect the manifold from ice and snow. In summer, shade the manifold and cylinders from continuous exposure to direct sunlight.

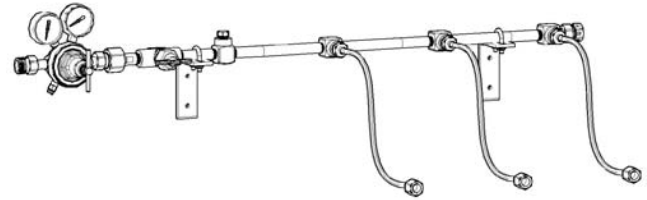

PX-RWP Series

Leave all protective covers in place until their removal is required for installation. This precaution will keep moisture and debris from the piping interior.

CAUTION

Failure to follow the following instructions can result in personal injury or property damage:

- Never permit oil, grease, or other combustible materials to come in contact with cylinders, manifold, and connections. Oil and grease may react with explosive force when ignited while in contact with some gases – particularly Oxygen and Nitrous Oxide.
- Cylinders, header and master valves should always be opened *very slowly*. Heat of recompression may ignite combustible materials creating an explosive force.
- Pigtails should never be kinked, twisted or bent into a radius smaller than 3 inches. Mistreatment may cause the pigtail to burst.
- Do not apply heat. Oil and grease may react with explosive force when ignited while in contact with some gases – particularly Oxygen and Nitrous Oxide.
- Cylinders should always be secured with racks, chains, or straps. Unrestrained cylinders may fall over and damage or break off the cylinder valve which may propel the cylinder from its current position with great force.
- Oxygen manifolds and cylinders should be grounded. Static discharges and lighting may ignite materials in an oxygen atmosphere, creating an explosive force.
- Welding should not be performed near Nitrous Oxide piping. Excessive heat may cause the gas to dissociate, creating an explosive force.

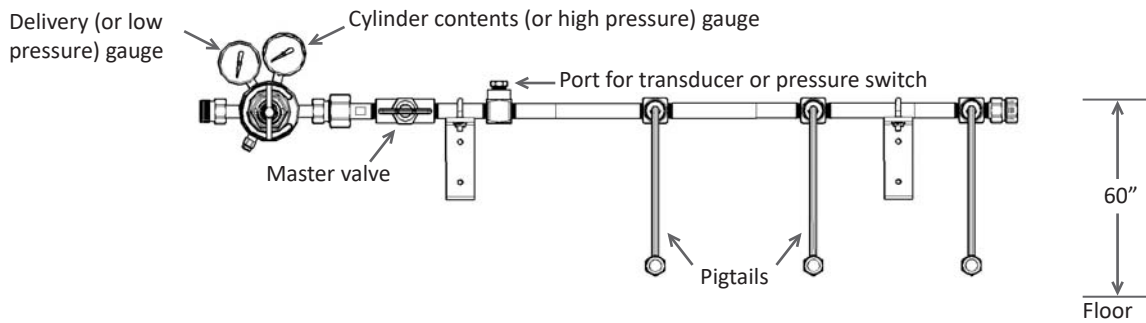

Manifold Assembly

This drawing illustrates the proper assembly for a typical installation and details the use with either a transducer or a pressure switch. The PX-17-0234 manifold outlet fitting is not used when the PX-RWP is to be connected directly to the PX-LLU cabinet as a primary or secondary bank.

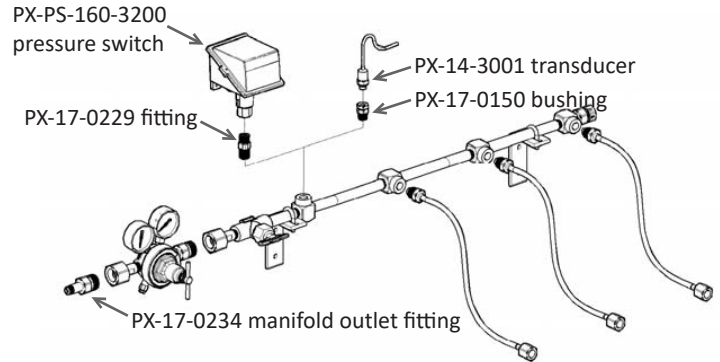

Manifold Installation

1. Determine and mark the vertical center line for installation of the manifold control cabinet.
2. Measure from the floor to a point 60" in height* above the finished floor of this vertical line. Using a level, mark a horizontal line at this point extending approximately 15" to the left and 15" to the right of center. This line indicates the location for the bottom two mounting bolts of the manifold control cabinet. (* - suggested manifold height. Wall mounting heights may vary depending on available space, cylinder height, etc.)
3. Remove the U-bolt assemblies from the header mounting brackets. Position the brackets so that the top of the bracket is aligned with the bottom of the headers and is centered between the cylinder connections. The end bracket should be placed as close to the last cylinder as possible to provide the most support and stability.
4. Mark the mounting hole and install fasteners suitable for type of wall construction.
5. Fit the U-bolt over the header piping and tighten the two mounting nuts.

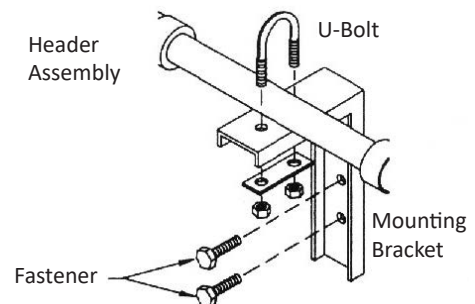
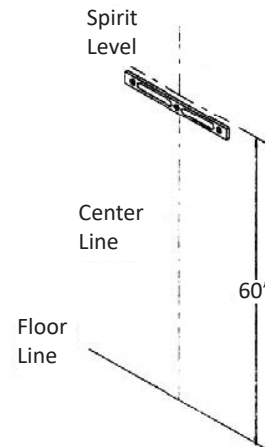

RWP as a Secondary Bank

If the installation is as a secondary supply on a preferential logic PX-LCU system (as shown here) it will not be necessary to use the PX-17-0234 manifold outlet fitting. The PX-RWP will connect directly to the PX-LCU cabinet. Note: This system must always be configured with the portable bulk vessel as the left primary supply and the high pressure reserve on the right side. Note: The system shown here does not comply with NFPA 99.

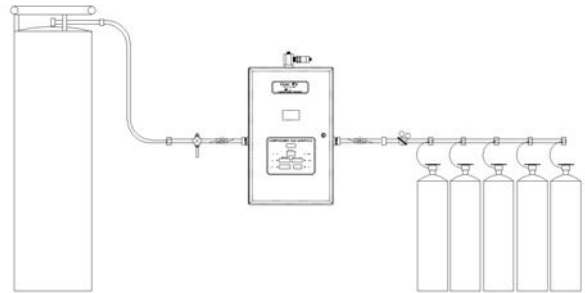

RWP as an Emergency Reserve Bank

If the installation is as an emergency reserve supply on a PX-LLU system (as shown here) it will be necessary to use the PX-17-0234 manifold outlet fitting. Please refer to the Genesys Manifold Installation & Operating Instruction Manual for details regarding NFPA 99 compliant installation.

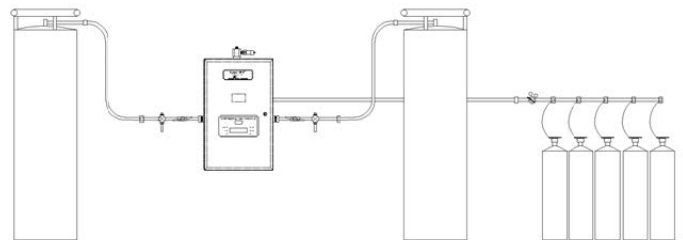

Start Up and Checking Procedures

1. The pigtails will be either rigid copper (for oxygen service) or braided stainless steel flexible (for all other gas services). The pigtails must be attached to the RWP header on one end and to the compressed gas cylinders on the other end. The pigtails do not have check valves so it does not matter which end of the pigtail is attached to the header or the cylinder. Check the 3 digit CGA (Compressed Gas Association) that is stamped on the fittings on the pigtail, the manifold header connection fittings and the cylinder valve – all 4 of these connections should have the same 3 digit CGA number. Oxygen is CGA 540, Medical Air is CGA 346, Nitrous Oxide is CGA 326, Carbon Dioxide is CGA 320 and Nitrogen is CGA 580. Using tools and hands which are free of oil and grease, attach the pigtails to the header connections and to full cylinders.
2. Back out the regulator adjusting handle. This will protect the system from being over pressurized when opening the cylinders.
3. The master valve should be fully open at all times. NOTE: this valve is provided for emergency shut off only.
4. Slowly open the cylinder valves until they are fully open. The cylinder contents gauge will show the bank pressure.
5. Use an oxygen safe leak test solution to test all connections for leakage. Correct any leaks found immediately.
6. Adjust the delivery pressure by turning the regulator adjusting screw clockwise until the desired pressure is achieved. It is best to set the delivery pressure while flowing a slight flow (2 or 3 lpm) of gas.
7. If a pressure switch has been installed in the port on an RWP system, it will monitor the bank pressure and trigger any alarm to which it is connected when the pressure depletes below its set point.
8. If a transducer has been installed in the port on an PX-RWP system, it together with the PX-LLU manifold logic board will display and monitor the bank pressure and trigger any alarm to which it is connected when the pressure depletes below the programmed set point. In addition, should the transducer go bad an alarm condition will be triggered immediately.
9. Simulate a depleted bank by closing the cylinder valves and creating a flow of gas through the manifold. The cylinder contents pressure readings will drop. Any alarms connected to the port on the system monitoring the bank pressure will be triggered.
10. Slowly open the cylinder valves until they are fully open. The cylinder contents gauge will show the bank pressure.
11. The manifold is now ready to supply your system.

Cylinder Replacement & Handling

1. Shut off all cylinder valves on the depleted bank of cylinders.
2. Slowly disconnect the pigtail CGA fitting from the depleted cylinders.
3. Remove depleted cylinders and replace the protective caps.
4. Place depleted cylinders in the area designated for empty cylinders and secure using approved chain, straps, stands or brackets.
5. Place full cylinders in position and secure using approved chain, straps, stands or brackets.
6. Remove protective cylinder caps from full cylinders. Remove any plastic dust caps from inside the cylinder valve. With the valve outlet pointed away from all personnel, quickly open then close each cylinder valve slightly to blow out any dirt or contaminants which may have become lodged into the cylinder valve.
7. Connect pigtails to the cylinder valves and tighten with the proper size oil free wrench.
8. Slowly open each cylinder valve until they are fully open.
9. The manifold is now ready to supply your system.

General Maintenance

Schedule	Control Cabinet	Headers & Pigtail
Daily	Record line and bank pressure	Observe nitrous oxide and carbon dioxide systems for cylinder frosting or surface condensation. Should excessive condensation or frosting occur it may be necessary to increase manifold capacity.
Monthly	Check regulators, fittings and valves for external leakage. Check valves for closure ability. Alternate line regulator in use (if dual).	Inspect valves for proper closure. Check pigtails for cleanliness, flexibility, wear, leakage, kinked, pinched or twisted and thread damage. Replace damaged pigtails immediately. Inspect header check valve outlets for closure ability.
Annually	Check relief valve pressures Check regulator seats.	
Every 4 years		Replace all pigtails