

Medical Desiccant Dryer Package

The PMD series desiccant dryer is designed to remove moisture and contaminants from the compressed air. The air is treated to provide air quality exceeding the specification of NFPA99 level 1 medical air.



Pressure Swing Adsorption: Each dryer contains two vessels filled with moisture adsorbent material (activated alumina). The dryer uses a fully automatic pressure swing adsorption cycle in which one tower is online in a drying phase while the other is offline, either regenerating or waiting for its next drying phase. A small percentage of the dry air is taken from the online tower and used to regenerate or purge the saturated tower. The moisture from the regenerating tower is vented to atmosphere. The towers alternate between phases based on either time or dew point status, depending on the mode of operation.

Ceramic Switching Valve: Switching valves are the weakest link in most desiccant dryer designs—not so with the ceramic valve. Inside the valve, a pair of sliding ceramic plates forms a nearly perfect, almost indestructible seal. The near diamond hard plates wipe themselves clean. The ceramic plates are warranted for the life of the valve.

Automatic Purge Saver: Each dryer is equipped with an automatic dew point dependant purge control system that reduces the amount of purge air during periods of low demand. Most dryers operated on a fixed time cycle purging air needlessly. This causes the compressors to run more often and wastes energy. With the intelligent purge saver controls, purge air waste is reduced by as much as 80% depending on conditions.

Filtration: Each dryer is provided with two stages of filtration. The pre-filter (installed before the desiccant dryer) removes liquid and particulates and includes an element change indicator and automatic condensate drain. The final filter removes particulates and includes an element change indicator.

Control Panel: The UL listed control panel is equipped with a lighted 3-position switch for selection of the following modes: Off / Fixed Mode / Purge Control Mode. A green LED is provided indicating when the dryer is operating in purge saving mode.

Tower Pressure Gauges: Pressure gauges are provided for each desiccant tower to provide indication of system status and operation.

Purge Muffler: Silencers are provided for each desiccant tower to reduce the noise level of the purge air venting to atmosphere.

Dew Point Monitor: The system-integrated hygrometer shall be equipped with an LCD dew point display and high dew point alarm with dry contacts for remote monitoring. The dew point sensor (probe) shall be installed so that the monitored airflow is downstream of the pressure regulator assembly. The sensor shall include an auto calibration feature to ensure the accuracy of the dew point measurement without the need to return the sensor to the factory for calibration.

Carbon Monoxide Monitor: The carbon monoxide (CO) monitor is provided in an enclosure with LCD display of CO concentrations. The monitor shall continuously display the CO content of the discharge air and shall provide audible and visual high CO alarms. High alarm is set at 10 ppm per NFPA99. Dry contacts are provided for remote monitoring of the high CO alarm.

ENGINEERING SPECIFICATIONS

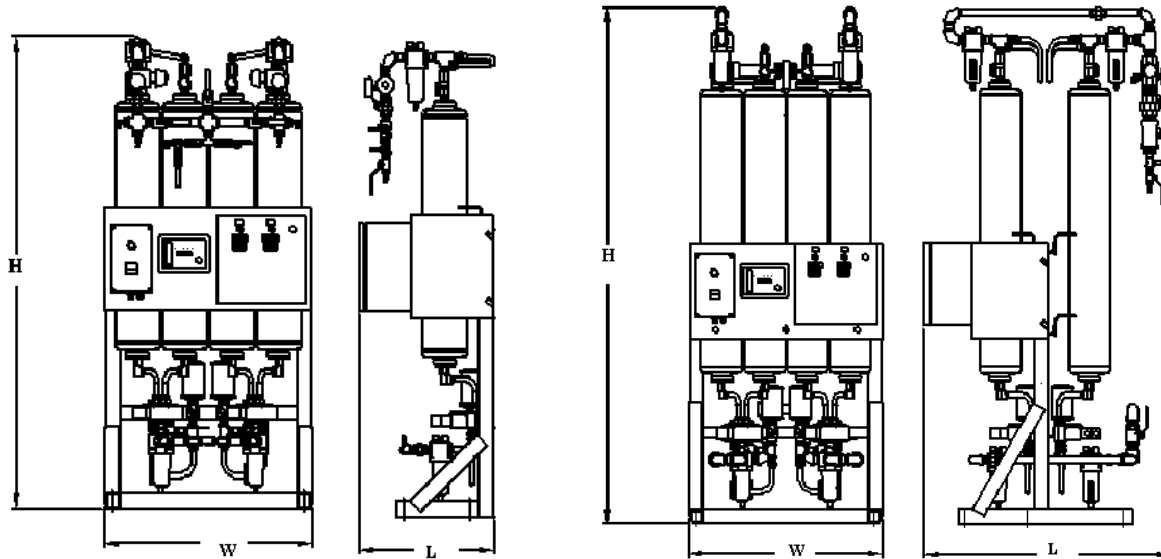

Fig. A

Fig. B

Model	SCFM @100 PSIG	Inlet	Outlet	Max Pressure	Voltage**	Dimensions (LxWxH)*
MDD0058	6.5	1/2"	1/2"	125	115V or 208-230V	18" x 29" x 54" (Fig. A)
MDD0108	10	1/2"	1/2"			18" x 29" x 54" (Fig. A)
MDD0158	17	1/2"	1/2"			18" x 29" x 54" (Fig. A)
MDD0308	30	1/2"	3/4"			18" x 29" x 64" (Fig. A)
MDD0358	45	3/4"	3/4"			18" x 29" x 73" (Fig. A)
MDD0558	55	3/4"	1"			18" x 29" x 73" (Fig. A)
MDD0708	110	1"	1 1/2"			36" x 29" x 81" (Fig. B)

*Dimensions are approximate

Drawings for reference only

Note: Dryer Sizing - SCFM listed is for each dryer. Powerex Medical Dryer Systems provide 100% backup. When selecting the proper Medical Dryer System, match the listed SCFM with the SCFM of the compressor(s) in operation with one compressor in reserve per NFPA 99. Includes: filter package, CO monitor, and Dew point monitor.

** Dryer available in either 115 V or 208-230 V. Please specify voltage when ordering.



150 Production Drive, Harrison, Ohio 45030
 Telephone: (888)769-7979 Fax: (513) 367-3125
 www.powerexinc.com

Distributed By: