

Digital Dew Point Monitor - PDPM1001

Please read and save these instructions. Read carefully before attempting to assemble, install, operate or maintain the product described. Protect yourself and others by observing all safety information. Failure to comply with instructions could result in personal injury and/or property damage! Retain instructions for future reference.

Description

The Powerex Digital Dew Point Monitor is designed to monitor the dew point of compressed air. The unit is equipped with an internal sensor with an external quick connector.

The dew point sensor utilizes an advanced polymer sensor technology and patented measurement technology to ensure accurate measurement with excellent long term stability. This results in very low maintenance requirements for the transmitter. The lasting performance is achieved with microprocessor technology and software that automatically performs self-diagnostic functions in addition to the normal dew point measurement. The self diagnostic procedures that are conducted are called auto-calibration, sensor purge and sensor warming.

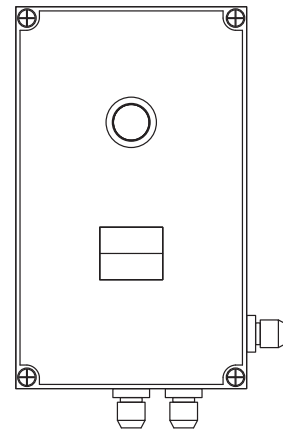

Safety Guidelines

This manual contains information that is very important to know and understand. This information is provided for SAFETY and to PREVENT EQUIPMENT PROBLEMS. To help recognize this information, observe the following symbols.

⚠ DANGER *Danger indicates an imminently hazardous situation which, if not avoided, WILL result in death or serious injury.*

⚠ WARNING *Warning indicates a potentially hazardous situation which, if not avoided, COULD result in death or serious injury.*

⚠ CAUTION *Caution indicates a potentially hazardous situation which, if not avoided, MAY result in minor or moderate injury.*

NOTICE *Notice indicates important information, that if not followed, may cause damage to equipment.*

CALIFORNIA PROPOSITION 65

⚠ WARNING *This product contains chemicals, including lead, known to the State of California to cause birth defects and other reproductive harm. Wash hands after handling.*

Specifications

Dew Point Range	-60° F to +54° F
Sensor Output	0V-5V Scaled as: below -60° F to over +54° F
Alarm Indication	Audible Alarm, Red Alarm Light with push to test, and push to acknowledge.
Alarm Output	10 AMP @ 115 VAC rated contact. Contact opens when in Alarm.
Alarm Horn	95±5 dB(A), at 120 VAC, at 24 inches (61 cm), at 25° C
Alarm Set Point	HIGH ALARM: Medical: +35° F (2.2° C) Lab: +40° F (4.4° C)
Dryer Control Signals - Medical application	10 AMP @ 115 VAC Rated Contact. (Normally Open) Contact Open for Purge rate fixed mode: -10° F to +54° F Contact Closed for Purge Saver mode: Below -15° F
Accuracy	±3° C dew point
Dimensions	9.1 inch x 5.5 inch x 5 inch
Net Weight	5 lbs.
Enclosure	Polycarbonate NEMA-4X electrical box, UL Listed. Wall mountable or portable with removable front cover.
Power Requirements	110- 120 VAC +10%, 60Hz
Fuse	Type FNM 1.25-amp
Operating Pressure	10 psig- 150 psig with a minimal flow rate
Operating Temperature	32° F to 131° F

Digital Dew Point Monitor

General Safety Information

1. Read all manuals included with this product carefully. Be thoroughly familiar with the controls and the proper use of the equipment.
2. Follow all local electrical and safety codes as well as in the United States, the National Electrical Codes (NEC) and Occupational Safety and Health Act (OSHA).
3. Only persons well acquainted with these rules of safe operation should be allowed to use the unit.
4. Before each use, inspect compressed air system and electrical components for signs of damage, deterioration, weakness or leakage. Repair or replace defective items before using.
5. Check all fasteners at frequent intervals for proper tightness.

Installation

APPLICATION HINTS

1. Do not expose the sensor to temperatures greater than 130° F.
2. Avoid installations with oil or separated water in the line. These contaminants cause premature sensor failure.

MOUNTING THE ENCLOSURE

Enclosure requires ample spacing for wiring and air input connection. Minimum space between monitor and other objects should be 2 inches. Enclosure has predrilled holes, however if an alternative pattern is required the enclosure can be drilled.

CAUTION *If drilling is required, be sure to drill from the inside-out so as not to damage the components or sub-plate. If new mounting holes are drilled, NEMA-4 gaskets must be used with fasteners in order to keep the NEMA rating.*

POWER CONNECTION

Connect 110-120VAC per wiring diagram illustration. "L" is line and "N" is neutral. Be sure to connect ground wire to ground lug on sub-plate.

Models equipped with a power cord should be plugged into a 120VAC, 15-amp circuit.

WARNING *All wiring and electrical connections should be performed by a qualified electrician. Installation must be in accordance with local codes and national electrical codes.*



REMOTE ALARM CONNECTION

The monitor is equipped with two relay output contacts that switch state when the reading reaches an alarm state or when the reading is low. The low signal is to allow for a purge saver mode on dryers with that option.

The built in audible alarm can be silenced by pressing the Red Light on the front panel. This switch does not affect the status of the remote alarm output.

Refer to the wiring diagram for details on alarm connection.

1. Route wires through cord grips on the side of the dew point monitor. A single 4-conductor cable is recommended (18-20 awg MTW).
2. Connect wires to terminal strip on bottom of controller.
 - Q-1 is normally open. The contact is closed when the dew point is below Alarm set point
 - Q-2 is normally open. The contact closes when dew point is below Purge saver set point.

PLUMBING CONNECTION

The connection requires a 1/4 (0.25) inch OD flexible tube to deliver the sample air at the sample port quick connector located on the bottom of the monitor. The sample port has a precision bleed orifice to allow a constant flow of air. **DO NOT** remove, plug, connect to or damage the orifice. The orifice will need to be cleaned periodically (3-months is recommended).

Operation

BEFORE USE

1. Make sure all safety warnings, labels and instructions have been read and understood before continuing.
2. Remove any shipping materials, brackets, etc.
3. Confirm that the electric power source is correct and ground have been firmly connected.
4. Check that all fuses, circuit breakers, etc., are the proper size.

START-UP

Once the monitor is installed, it will automatically assess the dew point of the compressed air for the system it is attached. The monitor is programmed to test and display the dew point.

NOTE: Start-up self-diagnostics freeze the output display during the first minutes of operation. Typical warm-up time is up to eight (8) minutes before the normal operation.

DISPLAY

During operation, the unit is designed to monitor the dew point of compressed air within a hi/low range of -60° F to +54° F. The digital display will show one of the following in degrees Fahrenheit (xx° F).

Below is a list of normal display readings:

- ◆ Dewpoint Below -60° F
- ◆ Dewpoint in Alarm Above +54° F
- ◆ Dewpoint xx° F GO TO FIXED
- ◆ Dewpoint xx° F Low GO TO ECON
- ◆ Dewpoint xx° F High GO TO ALARM

In the display, xx stands for current dewpoint reading.

CAUTION *To change the digital display to degrees in Celcius (°C), contact your Authorized Powerex Distributor.*

Maintenance

⚠ WARNING *Disconnect, tag, and lock out power source, then release all pressure from the system before attempting to install, service, relocate or perform any maintenance.*



SENSOR CALIBRATION AND ADJUSTMENT

The sensor is fully calibrated as shipped from factory (see calibration sheet included in main system manual). With the Daily Auto-Calibration feature (listed below) the sensor may not need replacement for up to 10-years. The manufacturer recommended replacement interval is 2 years from system start-up or if sensor should malfunction.

REPLACING THE FILTER

The sensor is protected with a stainless steel sintered filter. The filtering grade is 34 um.

The filter is recommended to be changed whenever it looks dirty or as a part of the periodical maintenance procedure. The recommended replacement interval depends heavily on the application and can vary from less than a year up to several years. Dirty or corroded filter may cause increased response times. In case the sensor is used in a drying system with silica gel (or other drying agent) the dust from the dryer may collect on the sensor slowing the response but also generating a micro climate around the sensor altering the dewpoint at the sensor. This is easily corrected by changing or cleaning the filter.

⚠ CAUTION *Touching the sensor may damage it. Special attention shall be paid to avoid touching the sensor when removing and replacing filters.*

⚠ WARNING *Disconnect, tag, and lock out power source, then release all pressure from the system before attempting to install, service, relocate or perform any maintenance.*



DAILY AUTO-CALIBRATION

The Daily Auto-Calibration feature of the sensor is an automatic procedure which greatly reduces the possible drift in the dry end of the dewpoint measurement. It is performed at one hour intervals, and when the power is switched on. During auto-calibration the sensor is warmed for a short period (< 1 min) and the sensor capacitance values are evaluated at the elevated temperature. The possible dry end drift is then corrected to correspond to the calibrated values. During the auto-calibration the transmitter outputs the Td value prior to the procedure. Auto-calibration is carried out only if several criteria for the measurement environment are fulfilled. This ensures the reliability of the adjustments, and maintains the excellent long term stability that the patented technology offers. These criteria include e.g. a sufficiently stable enough moisture level in the measured atmosphere. If the conditions are not fulfilled, the auto-calibration function is postponed until the satisfied conditions are reached.

SENSOR PURGE

Sensor purge is also an automatic procedure that minimizes the drift at the wet end readings of the dewpoint measurement. Sensor purge is performed once a day or when the power is switched on. The sensor is heated for several minutes which will then evaporate all excess molecules out of the sensor polymer. This, together with the auto-calibration results in a very small drift of the sensor due to the very linear behavior of the polymer technology.

SENSOR WARMING IN HIGH HUMIDITIES

Additionally the sensor has a warming feature which prevents the sensor and filter from becoming wet in high humidity's. High humidity can be present when the dewpoint temperature rises close to the gas temperature. Sensor warming is switched on automatically when the humidity level in the measured gas increases to a level where dew can start to form. The advantage of sensor warming is rapid response of dewpoint measurement. A wet sensor and filter would otherwise result in a dewpoint equal to ambient temperature (i.e. RH=100%). If the sensor becomes soaked in any way, it will fully recover and return back to normal operation after it dries out.

Digital Dew Point Monitor

Wiring Diagram

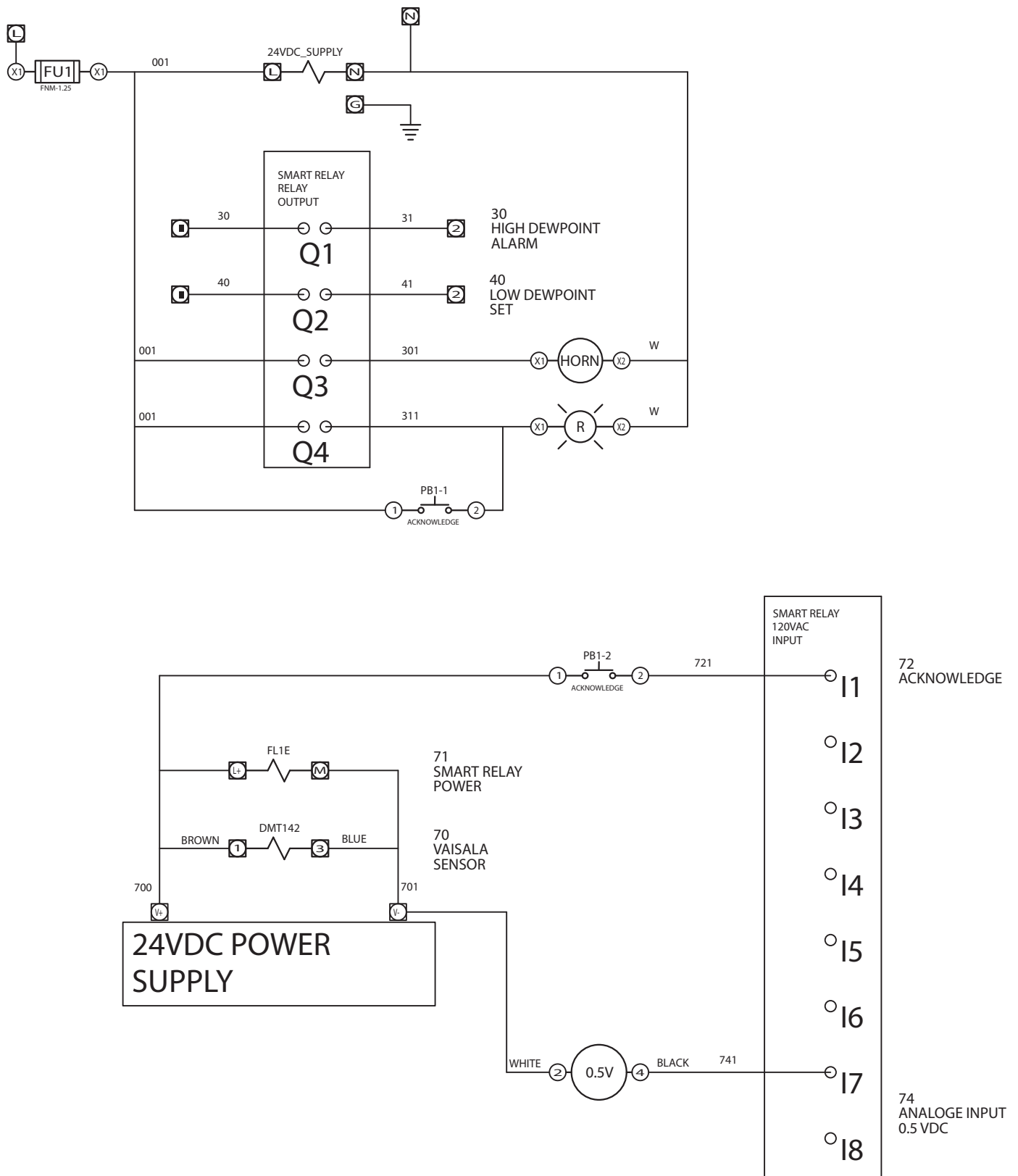

Figure 1

Parts List

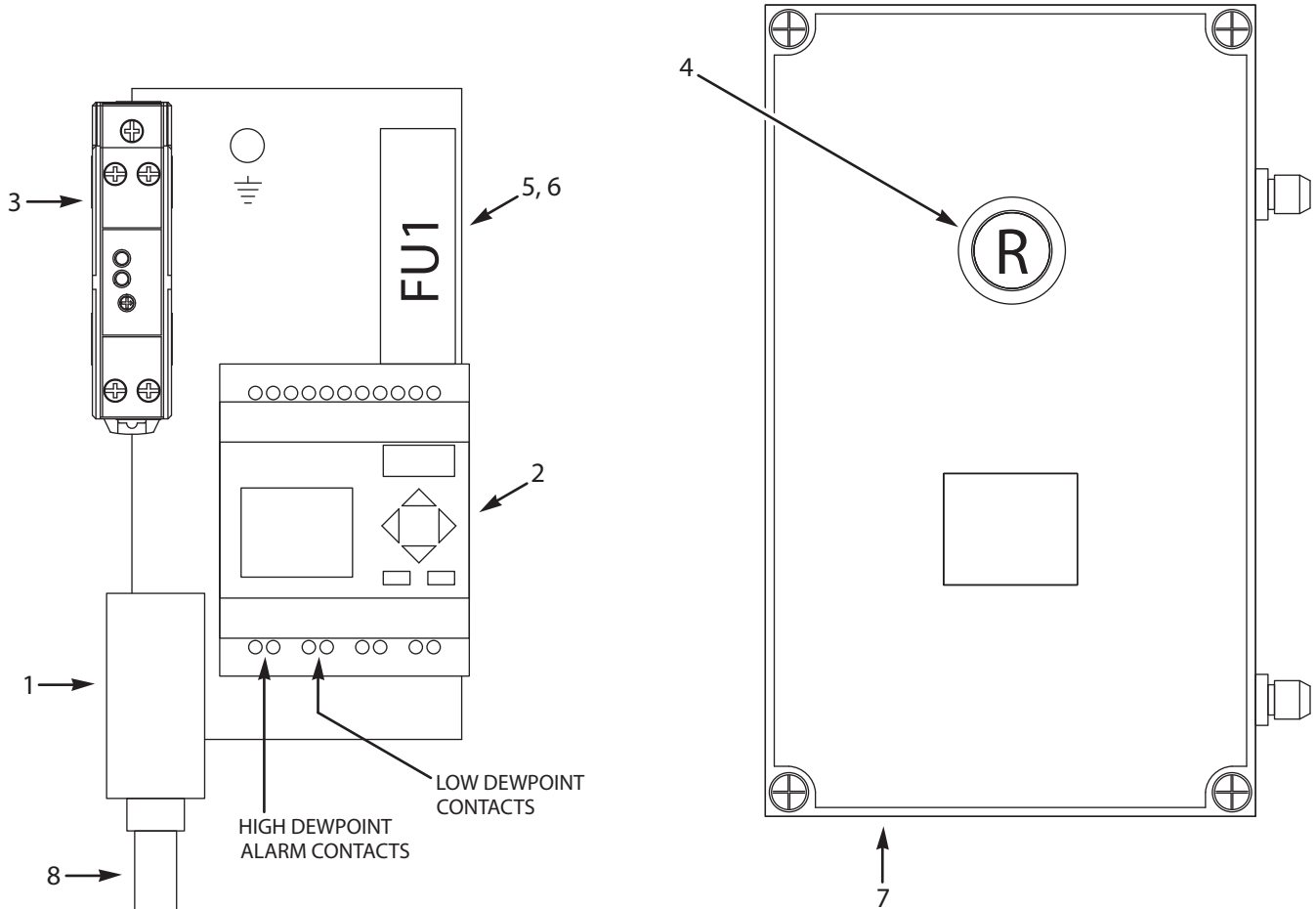

Figure 2

Ref. No.	Description	Part Number	Qty.
1	Dew Point Sensor	ACO500106	1
2	Monitor Controller	PE000429AV	1
3	24 Volt Power Supply	PE000430AV	1
4	Illuminate Push Button	PE000555AV	1
5	Fuse	JP007711AV	1
6	Fuse Block	JP007802AV	1
7	Bleed Orifice *	ST189002AV	1
8	Filter	ST194302AV	1
*	Not Shown		

Digital Dew Point Monitor

Troubleshooting Guide

PROBLEM	CAUSE	CORRECTIVE ACTION
Non Operational/ No display	<ol style="list-style-type: none">1. Blown Fuse2. Internal power supply failure3. Controller failure4. Conductor or cable connection	<ol style="list-style-type: none">1. Replace main fuse2. Verify there is 24Vdc from power supply, if not contact authorized distributor for replacement.3. Press "Esc" on front of controller, if no characters are displayed contact authorized distributor for replacement. If controller displays characters refer to next section.4. Verify all cables and conductors are securely connected.
Display shows "Date and Time" or Setup Screen.	Controller Program Failure	Contact authorized distributor
Displays shows "Sensor Connection Fault"	Sensor cable is damaged or disconnected	Inspect cable for damage, verify connection to sensor, controller, and power supply...refer to drawing for connections
No Alarm Light	<ol style="list-style-type: none">1. LED Lamp burnt out2. Conductor connection	<ol style="list-style-type: none">1. Contact authorized distributor for replacement2. Check and verify conductor connection, see drawing
Alarm Horn	Conductor connection	Check and verify conductor connection, see drawing
No Alarm Signal	Conductor connection on terminal strip.	Check and verify conductor connection, see drawing. Contacts are energized closed...Contacts open when in Alarm.
Nuisance Alarm from dry contacts	Conductor connection on terminal strip.	Check and verify conductor connection, see drawing. Contacts are energized closed...Contacts open when in Alarm.
Dewpoint Temp incorrect	<ol style="list-style-type: none">1. Sensor needs replacement2. Sensor filter needs replacement3. Sensor has malfunctioned4. Air stream blocked	<ol style="list-style-type: none">1. Contact authorized distributor for replacement2. Contact authorized distributor for replacement, see "Replacing the filter" section in manual.3. Contact authorized distributor for replacement4. Verify air flow to sensor sample port and verify flow orifice is not clogged or damaged.

Powerex Limited Warranty

Warranty and Remedies.

(a) General. Powerex warrants each Compressor System, Vacuum System, Vacuum Pump, Compressor Air-End, or Powerex branded Accessory (collectively "Products", individually each a "Product") to be free from defects in material and workmanship ("Defects") at the date of shipment. EXCEPT AS SET FORTH BELOW, NO OTHER WARRANTY, WHETHER EXPRESS OR IMPLIED, INCLUDING ANY WARRANTY OF MERCHANTABILITY OR FITNESS FOR A PARTICULAR PURPOSE, SHALL EXIST IN CONNECTION WITH THE SALE OR USE OF SUCH PRODUCTS. TO THE EXTENT PERMITTED BY LAW, ANY AND ALL IMPLIED WARRANTIES ARE EXCLUDED. All claims under this warranty must be made in writing and delivered to Powerex, or such claim shall be barred. Upon timely receipt of a claim, Powerex shall inspect the Product claimed to have a Defect, and Powerex shall repair, or, at its option, replace, free of charge, any Product which it determines to have had a Defect at the time of shipment from Powerex; provided, however, that if circumstances are such as to preclude the remedying of Defect by repair or replacement, Powerex shall, upon return of the Product, refund to buyer any part of the purchase price of such Products paid to Powerex. Freight for returning Products to Powerex for inspection shall be paid by buyer. The warranties and remedies herein are the sole and exclusive remedy for any breach of warranty or for any other claim based on any Defect, or non-performance of the Products, whether based upon contract, warranty or negligence.

(b) Initial Period of Warranty – Parts and Labor. Powerex warrants and represents all Products shall be free from Defects for the first twelve (12) months from the date of shipment by Powerex, or five thousand (5,000) hours of use, whichever occurs first. During such warranty period, Powerex shall be fully liable for all Defects in the Products (the "Product Defects"), i.e., all costs of repair or replacement, which may include "in and out" charges, so long as the Products are located in the continental United States, and the Products are reasonably located and accessible by service personnel for removal. "In and out" charges include the costs of removing a Product from buyer's equipment for repair or replacement.

(c) Additional Period of Warranty – Parts Only (No Labor). In addition to the above, Powerex warrants each Powerex branded Compressor Air-End, and Vacuum Pump shall be free of Defects for a period of thirty-six months from the date of shipment of Product, or 10,000 hours of use, whichever occurs first. Supplier's repair or replacement of any Product shall not extend the period of any warranty of any Product. This warranty applies to the exchange of part(s) found to be defective by an Authorized Powerex Service Center only.

(d) Coverage. The above mentioned warranty applies to Powerex manufactured units or systems only.

(e) Exceptions. Notwithstanding anything to the contrary herein, Powerex shall have no warranty obligations with respect to Products:

- (i) that have not been installed in accordance with Powerex's written specifications and instructions;
- (ii) that have not been maintained in accordance with Powerex's written instructions;
- (iii) that have been materially modified without the prior written approval of Powerex; or
- (iv) that experience failures resulting from operation, either intentional or otherwise, in excess of rated capacities or in an otherwise improper manner.

(f) The warranty provided herein shall not apply to: (i) any defects arising from corrosion, abrasion, use of insoluble lubricants, or negligent attendance to or faulty operation of the Products; (ii) ordinary wear and tear of the Products; or (iii) defects arising from abnormal conditions of temperature, dirt or corrosive matter; (iv) any OEM component which is shipped by Powerex with the original manufacturer's warranty, which shall be the sole applicable warranty for such component.

Limitation of Liability. TO THE EXTENT ALLOWABLE UNDER APPLICABLE LAW, NOTWITHSTANDING ANYTHING TO THE CONTRARY HEREIN, UNDER NO CIRCUMSTANCES SHALL POWEREX BE LIABLE FOR ANY INCIDENTAL, CONSEQUENTIAL, PUNITIVE, SPECULATIVE OR INDIRECT LOSSES OR DAMAGES WHATSOEVER ARISING OUT OF OR IN ANY WAY RELATED TO ANY OF THE PRODUCTS OR GOODS SOLD OR AGREED TO BE SOLD BY POWEREX TO BUYER. TO THE EXTENT ALLOWABLE UNDER APPLICABLE LAW, POWEREX'S LIABILITY IN ALL EVENTS IS LIMITED TO, AND SHALL NOT EXCEED, THE PURCHASE PRICE PAID.

Warranty Disclaimer. Powerex has made a diligent effort to illustrate and describe the Products in this literature accurately; however, such illustrations and descriptions are for the sole purpose of identification, and do not express or imply a warranty that the Products are merchantable, or fit for a particular purpose, or that the Products will necessarily conform to the illustrations or descriptions.

Product Suitability. Many jurisdictions have codes and regulations governing sales, construction, installation, and/or use of Products for certain purposes, which may vary from those in neighboring areas. While Powerex attempts to assure that its Products comply with such codes, it cannot guarantee compliance, and cannot be responsible for how the product is installed or used. Before purchase and use of a Product, please review the Product applications, and national and local codes and regulations, and be sure that the Product, installation, and use will comply with them.

Claims. Claims pertaining to the Products, with the exception of warranty claims, must be filed with Powerex within 6 months of the invoice date, or they will not be honored. Prices, discounts, and terms are subject to change without notice or as stipulated in specific Product quotations. All agreements are contingent upon strikes, accidents, or other causes beyond our control. All shipments are carefully inspected and counted before leaving the factory. Please inspect carefully any receipt of Products noting any discrepancy or damage on the carrier's freight bill at the time of delivery. Discrepancies or damage which obviously occurred in transit are the carrier's responsibility and related claims should be made promptly directly to the carrier. Returned Products will not be accepted without prior written authorization by Powerex and deductions from invoices for shortage or damage claims will not be allowed. **UNLESS OTHERWISE AGREED TO IN WRITING, THESE TERMS AND CONDITIONS WILL CONTROL IN ANY TRANSACTION WITH POWEREX** any different or conflicting terms as may appear on any order form now or later submitted by the buyer. All orders are subject to acceptance by Powerex.