

## Oiless Tankmount Simplex

**Please read and save these instructions. Read carefully before attempting to assemble, install, operate or maintain the product described. Protect yourself and others by observing all safety information. Failure to comply with instructions could result in personal injury and/or property damage! Retain instructions for future reference.**

### Description

The OTS Series Powerex Simplex Air Compressors have been designed and tested to meet the most demanding specifications in the pneumatic oil free industry for reliability.

All Powerex air compressors have reliable operation and feature high quality construction and components. An unloader is included on all compressors to provide loadless starting. Powerex oilless pumps use composite piston technology, low compressor speeds and PTFE compression rings.

All 2 through 15 HP models are also equipped with a cooling fan and air control shroud to achieve low head temperatures to minimize ring wear.

Powerex compressor motors are NEMA Class B or better design. Single-phase 1HP motors have built-in overload protection and a DPST disconnect switch. Three-phase motors require a magnetic starter and adjustable overload which may be ordered as a factory mounted and wired option.

### Safety Guidelines

This manual contains information that is very important to know and understand. This information is provided for SAFETY and to PREVENT EQUIPMENT PROBLEMS. To help recognize this information, observe the following symbols.

#### **⚠ WARNING**

**Warning indicates a potentially hazardous situation which, if**

**not avoided, COULD result in death or serious injury.**

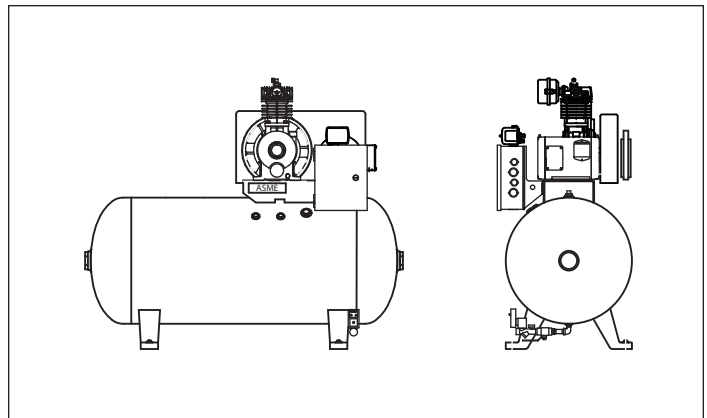
**NOTE:** Information that requires special attention.

#### **CALIFORNIA PROPOSITION 65**

#### **⚠ WARNING**

**This product or its power cord may contain chemicals**

**known to the State of California to cause cancer and birth defects or other reproductive harm. Wash hands after handling.**



### Specifications

Product	OTS Series Powerex Simplex Air Compressors
Performance Specifications	See Table 1
Dimensions and Weights	See Table 2
Lubrication	All Models with Oil Free Sealed Bearings
Operating Voltages	1Ø 1 to 1-1/2 HP 115/208 - 230 Volts, 60 Hz 2 to 5 HP 208 - 230 Volts, 60 Hz 3Ø 208-230/460 Volts, 60 Hz
Compression Cycle	1 Through 3 HP Models: Single-Stage 5 Through 15 HP Models: Two-Stage
Motor Overload Protection	1Ø Built-In Thermal Overload (Only 1 HP) 3Ø Magnetic Starter and IEC Adjustable Overload (Optional)
Pressure Settings	Cut-in: Factory Set at Approximately 90 psig Cut-out: Factory Set at Approximately 120 psig
Overpressure Protection	ASME Safety Valve Factory Set and Sealed at Approximately 140 psig
Outlet Air Connections	1/2 inch NPT on 1 HP - 3 HP 3/4 inch NPT on 5 HP - 15 HP
Tank Sizes	Available options are listed in Table 1
California Ordinance 462 (L) (2)	Meets Requirements of this Ordinance
Tank Isolation	Standard All Units

*The performance specifications are nominal and conform to acceptable industry standards. For application at conditions beyond these specifications, consult the local Powerex office. Powerex shall not be liable for damages resulting from misapplication or misuse of its products.*

## Oilless Tankmount Simplex

### Performance Specifications

Model	HP	Phase	SCFM @100 psig	RPM	Voltage	Gallon Tank
OTS110	1	1	3.6	625	115 / 208 / 230	30 / 60
OTS010	1	3	3.6	625	208 / 230 / 460	30 / 60
OTS115	1.5	1	5.3	885	115 / 208 / 230	30 / 60
OTS015	1.5	3	5.3	885	208 / 230 / 460	30 / 60
OTS120	2	1	6.5	845	115 / 208 / 230	60
OTS020	2	3	6.5	845	208 / 230 / 460	60
OTS130	3	1	10.1	1115	208 / 230	80
OTS030	3	3	10.1	1115	208 / 230 / 460	80
OTS151	5	1	16.5	800	208 / 230	80 / 120
OTS050	5	3	16.5	800	208 / 230 / 460	80 / 120
OTS075	7.5	3	26.1	855	208 / 230 / 460	80 / 120
OTS100	10	3	35.0	1090	208 / 230 / 460	120
OTS150	15	3	45.2	1140	208 / 230 / 460	120

**NOTE:** See Electrical Diagram Shipped with the Unit for Motor Full Load Amp Ratings

**TABLE 1: Oilless Tankmount Simplex - Model OTS**

### Operation

Factory calibrated snap-acting DPST pressure electric switches provide automatic cut-in and cut-out. Overpressure protection is provided by an ASME safety relief valve. Receiver tanks have a manual condensate drain valve with an extension for easy access. All mounting bases are slotted for V-belt tension adjustment.

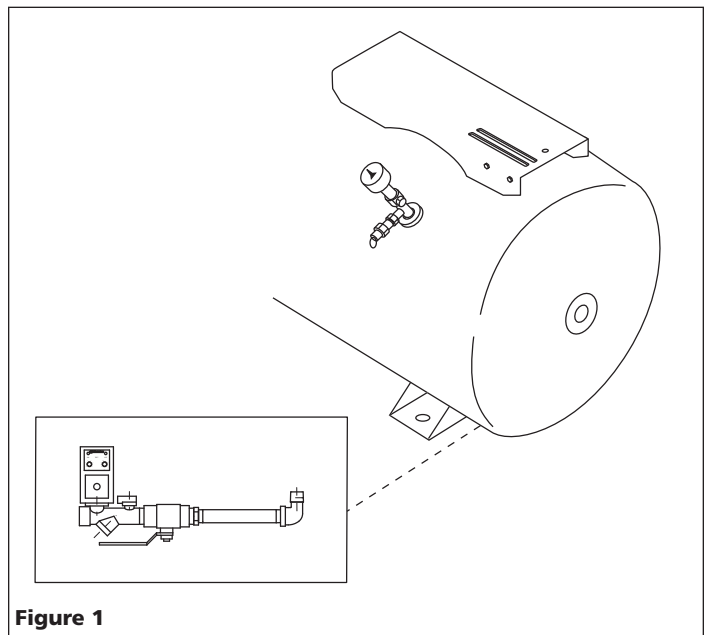
All units are run and tested for air delivery, leakage and power consumption.

Units are furnished with an 5 micron intake filter/ silencer(s) with a replaceable cartridge. This filter/ silencer combination is designed to remove contaminants in the inlet air and provide quiet operation.

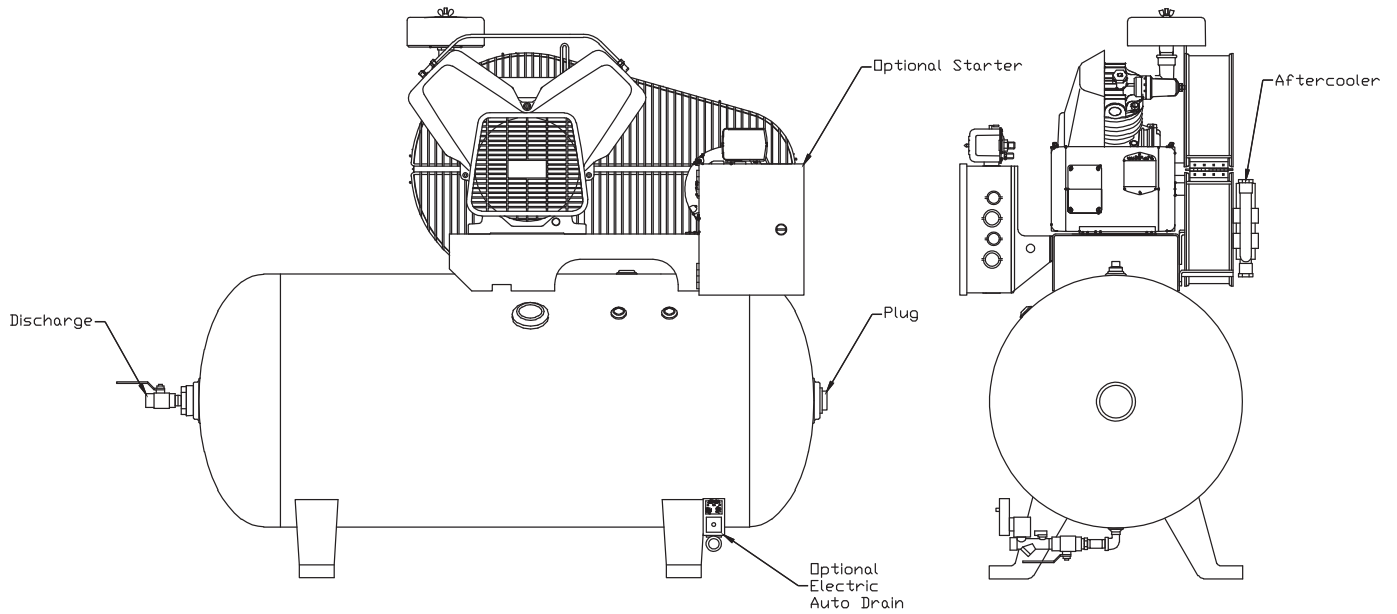
#### ELECTRIC DRAIN ASSEMBLY (SEE FIGURE 1)

**NOTE:** The automatic E-drain is assembled to tank.

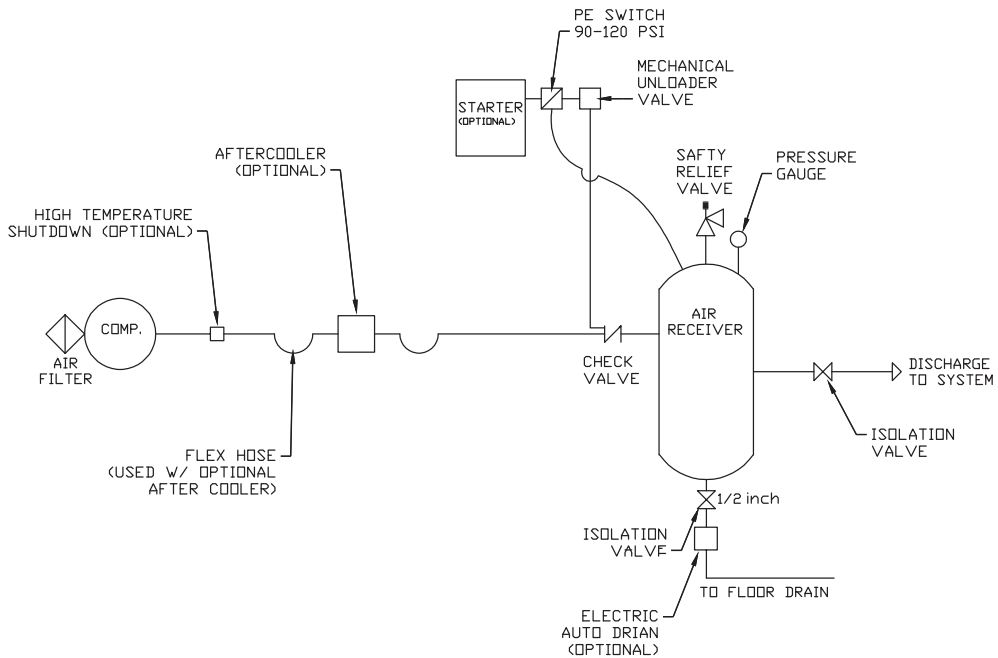
1. Plug E-drain into 115V power supply.
2. Adjust times accordingly.



**Figure 1**

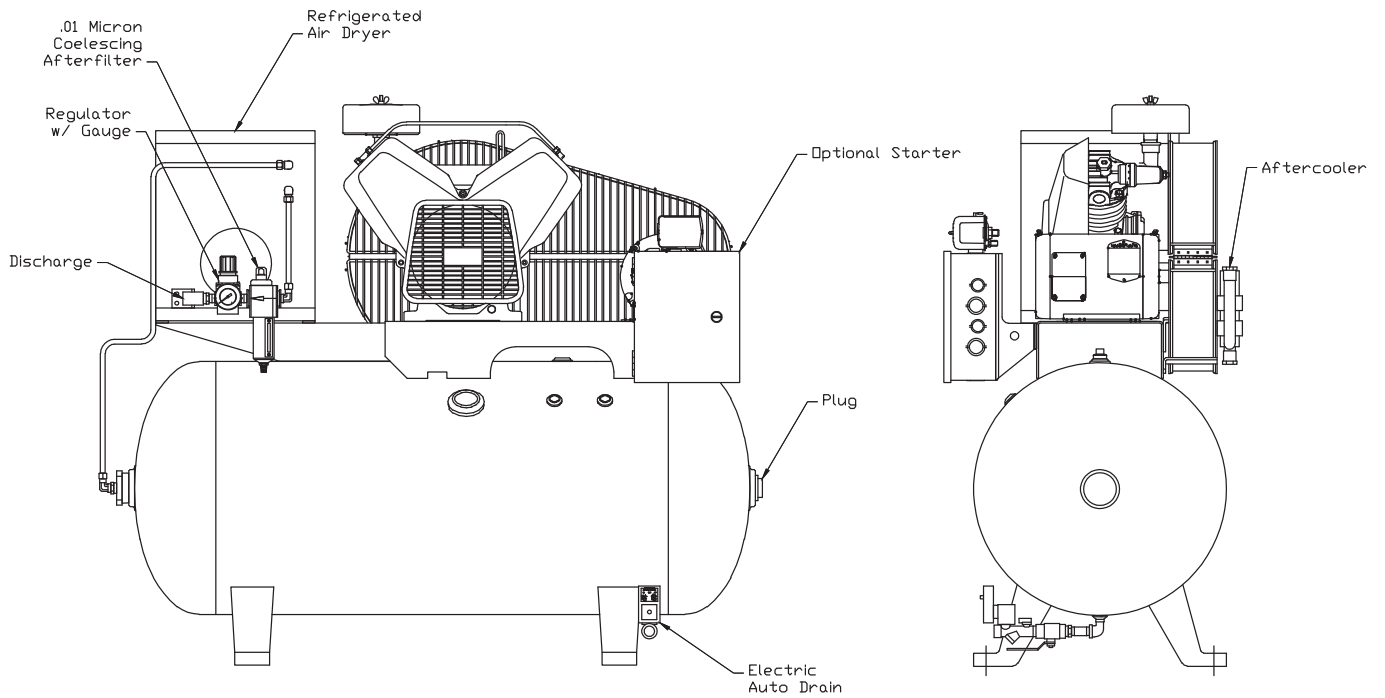


**Figure 2 - Standard Model Layout**

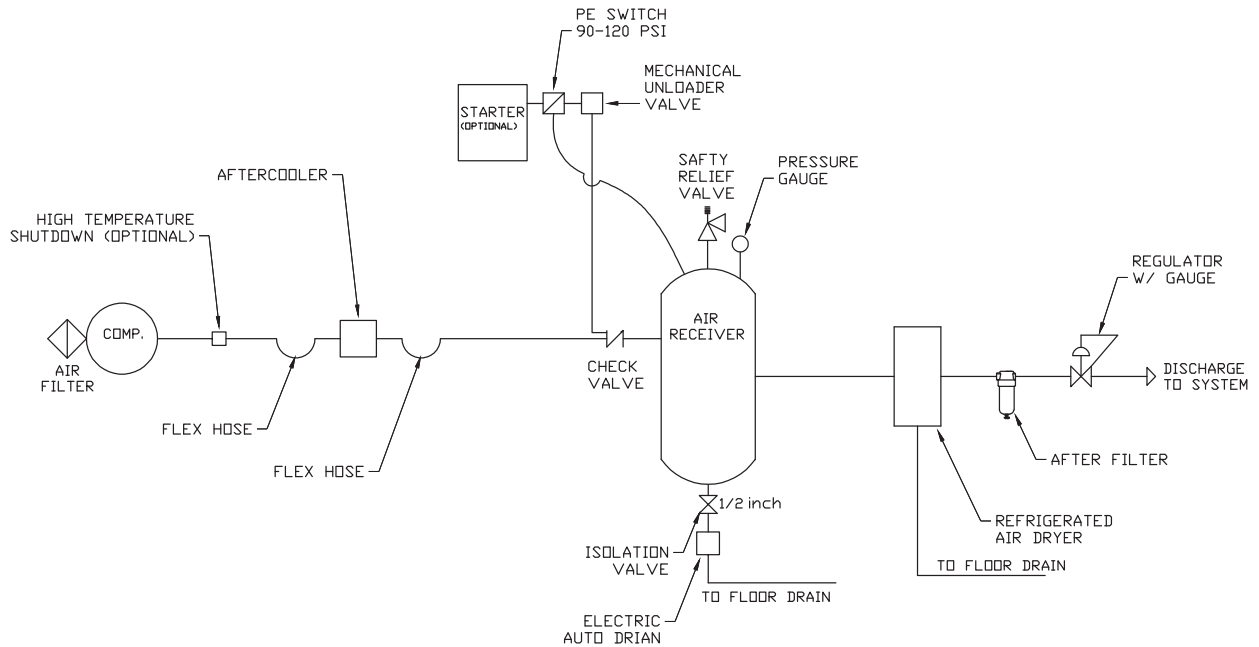


**Figure 3 - Standard Model Flow Schematic**

# Oilless Tankmount Simplex

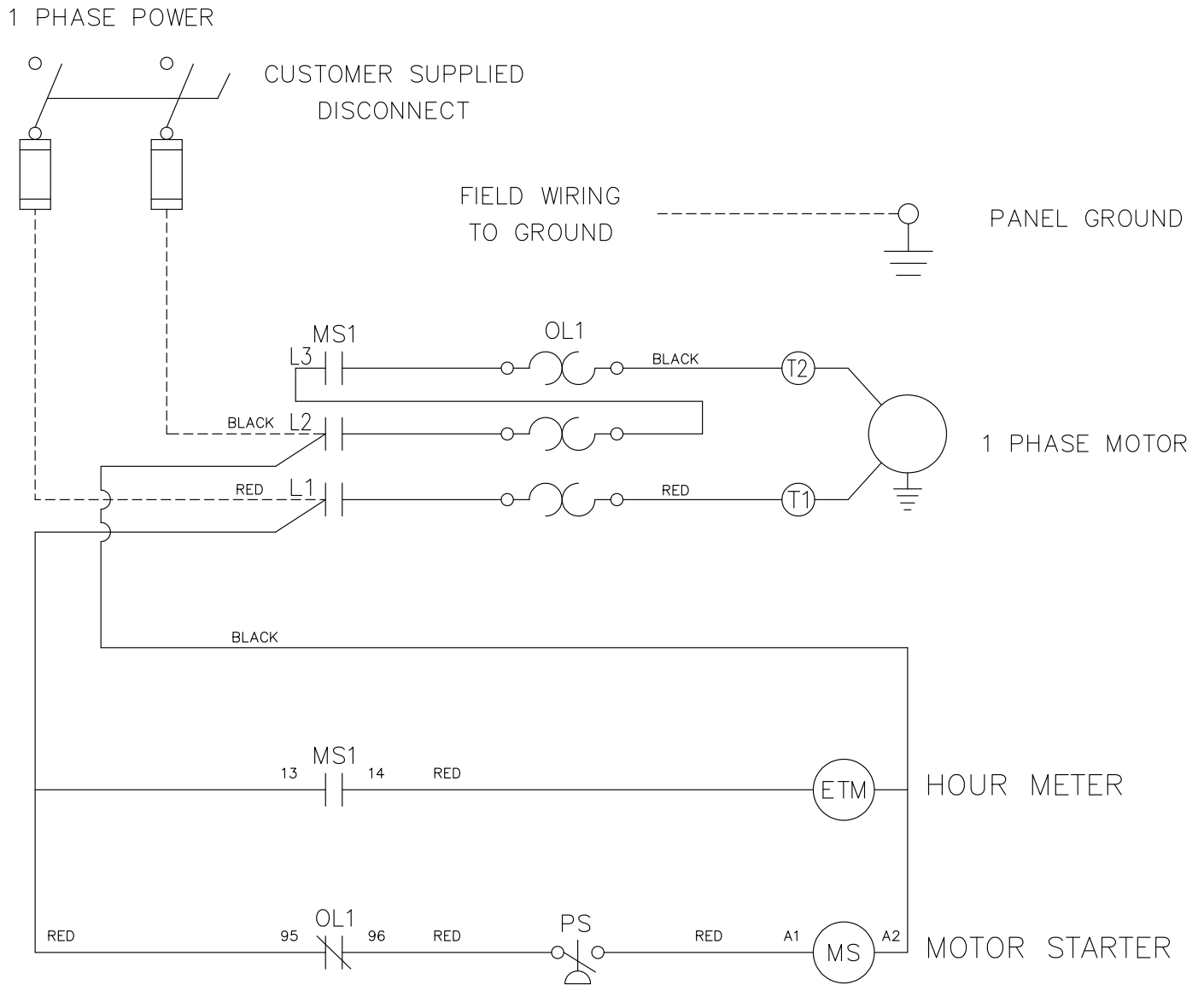


**Figure 4 - Refrigerated Dryer Option Layout**



**Figure 5 - Refrigerated Dryer Option Flow Schematic**

**Wiring Diagram**

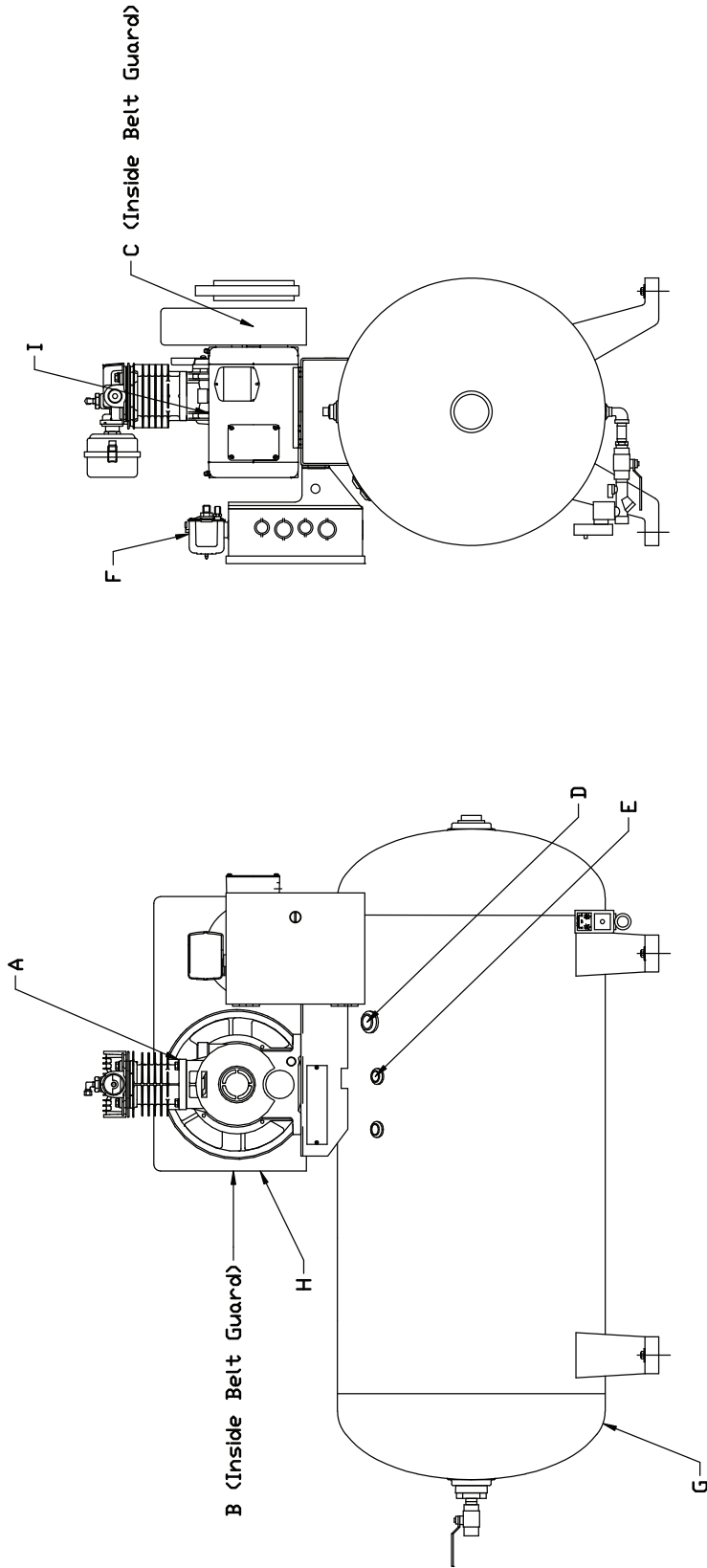


**Figure 6 - Single Phase**





**Replacement Parts List**

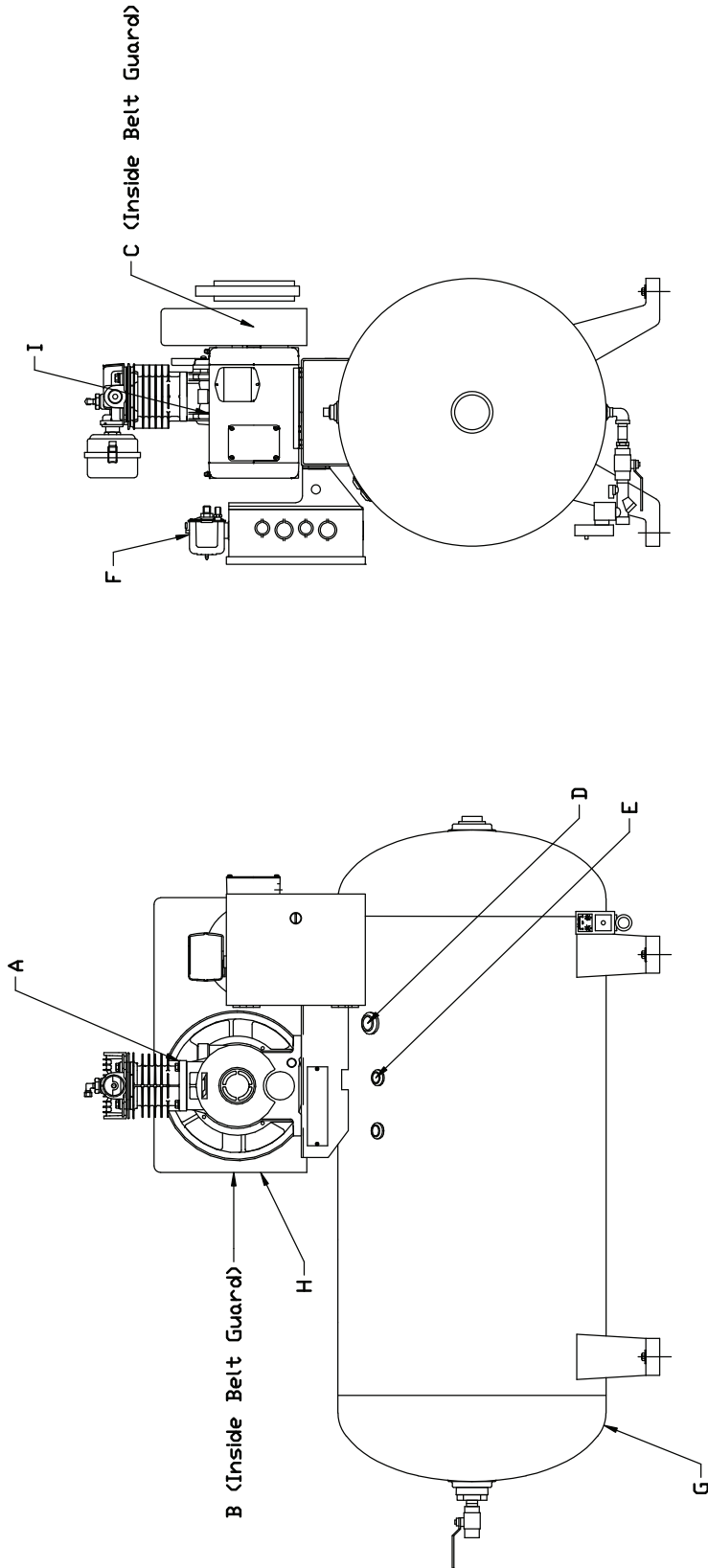




## Replacement Parts List

Item	Description		Quantity Required	Part Number	
A	<b>Pump and Flywheel:</b>	<b>Motor HP</b>			
		1, 1-1/2	1	OPS010	
		2, 3	1	OPS030	
		5	1	OPT050	
		7-1/2, 10	1	OPT100	
		15	1	OPT150	
B	<b>Belt:</b>	<b>Motor HP</b>	<b>Size</b>		
		1 (1 Ø)	A-43	1	BT009400AV
		1 (3 Ø)	AX-41	1	BT023300AV
		1-1/2	A-45	1	BT009500AV
		2	B-62	1	BT011300AV
		3	BX-66	1	BT008500AV
		5 (80, 120 gal tank)	B-68	2	BT022100AV
		7-1/2	B-84	2	BT011200AV
		10	B-87	2	BT009200AV
		15	B-92	2	BT010200AV
C	<b>Motor Pulley:</b>	<b>Motor HP</b>	<b>Type</b>		
		1 (1 Ø)	1A-4.0 inch P.D., 5/8 inch Bore	1	PU009723AV
		1 (3 Ø) (Uses 3450 Motor)	1A-2.0 inch P.D., 5/8 inch Bore	1	PU202617AV
		1-1/2	1A-5.5 inch P.D., 7/8 inch Bore	1	PU009725AV
		2 (1 Ø)	1B-6.4 inch P.D., 1.125 inch Bore	1	PU009787AV
		2 (3 Ø)	1B-6.4 inch P.D., 7/8 inch Bore	1	PU009778AV
		3	1B-8.4 inch P.D., 1.125 inch Bore	1	PU009777AV
		5	2B-7.4 inch P.D., 1.125 inch Bore	1	PU202634AV
		7-1/2	2B-8.6 inch P.D., 1.375 inch Bore	1	PU009775AV
		10	2B-11.0 inch P.D., 1.375 inch Bore	1	PU009772AV
15	2B-12.4 inch P.D., 1.625 inch Bore	1	PU009756AV		
D	<b>In-Tank Check Valve:</b>	<b>Motor HP</b>	<b>Size</b>		
		1 Through 3	1/2 inch MPT x 1/2 inch FPT	1	CV003204AV
		5 Through 15	3/4 inch MPT x 3/4 inch FPT	1	CV003205AV
E	<b>Safety Relief Valve:</b> Set at approximately 140 psig (1/2 Through 15 HP Models)		1	V-215100AV	
F	<b>Pressure Electric Switches:</b> (For all models) <b>Lead Switch:</b> Set at approximately 90 psig cut-in and 120 psig cut-out		1	CW207558AV	

**Replacement Parts List**



## Replacement Parts List

Item	Description	Quantity Required	Part Number	
G	<b>Tank:</b>			
	<b>Motor HP</b>			
	1 Through 1-1/2	30 gallon	1	AR022100ST
	1 Through 1-1/2	60 gallon	1	AR022200ST
	2	60 gallon	1	AR022500ST
	3	80 gallon	1	AR022300ST
	5	80 gallon	1	AR023400ST
	5	120 gallon	1	AR022400ST
	7-1/2	80 gallon	1	JQ001000AV
7-1/2 Through 15	120 gallon	1	TQ003201ST	
H	<b>Belt Guard:</b>			
	<b>Motor HP</b>			
	1 Through 1-1/2 (Whole Assembly - ZZ000605PX)		1	BG012400AV
	2, 3		1	BG012802AV
	5, Small 7-1/2 (Whole Assembly - ZZ006563AJ)		1	BG311400AV
	7-1/2, 10 (Whole Assembly - ZZ000620AJ)		1	BG218500AV
15 (Whole Assembly - ZZ000620AJ)		1	BG218500AV	
I	<b>Motor:</b>			
	<b>Motor HP</b>			
	1 (1 Ø)		1	MC022371AV
	1 (3 Ø)		1	MC301561AV
	1-1/2 (1 Ø)		1	MC022320AV
	1-1/2 (3 Ø)		1	MC304302AV
	2 (1 Ø)		1	MC022317AV
	2 (3 Ø)		1	MC304501AV
	3 (1 Ø)		1	MC022309AV
	3 (3 Ø)		1	MC304201AV
	5		1	MC304203AV
	7-1/2		1	MC304208AV
	10		1	MC304210AV
15		1	MC304212AV	
J	<b>Optional Refrigerated Dryer and Parts (not shown)</b>			
	<b>3 HP and under</b>			
	10 CFM Dryer		1	ACO016010
	Regulator		1	ST178408AJ
	.01µ Filter		1	ST178184AV
	.01µ Filter Element		1	ST178185AV
	Electric Auto Tank Drain		1	SL300701AV
Beltguard Mounted Aftercooler *		1	SL300100AV	

\* Part number includes only the Aftercooler. For complete Aftercooler Assembly, including mounting hardware and flex hoses, order part number ACO700015.

## Oilless Tankmount Simplex

### Maintenance Schedule

Item	Action needed	Operating Hours						Remarks
		500	2500	5000	10,000	15,000	20,000	
Tank	Drain moisture	Daily						Drain tank daily
Inlet Air Filter	Inspect, Replace	●	▲					Every 2500 hours or less
Blower Fan	Clean			●	●	●	●	
Fan Duct	Clean			●	●	●	●	
Compressor Fins	Clean		●					Every 2500 hours or less
Compression Rings	Inspect, Replace			●	▲	●	▲	
Wrist Pin Bearing	Regrease			▲	▲	▲	▲	Replace high pressure wrist pins
Piston Set	Inspect				●		●	
V-belt	Inspect, Replace		●	▲	▲	▲	▲	<b>Note 3</b>
Pressure Switch	Confirm operation				●		●	
Magnetic Starter	Inspect				●		●	Replace if contact point deteriorated
Safety Valve	Confirm operation		●					Every 2500 hours or less
Pressure Gauge	Inspect		●					Every 2500 hours or less
Check Valve	Replace						●	
Receiver	Inspect						●	Every 20,000 hours or per local codes

- Inspect
- ▲ Replace

#### Notes:

1. Inspect and perform maintenance periodically according to maintenance schedule.
2. The maintenance schedule relates to the normal operating conditions. If the circumstances and load condition are adverse, shorten the maintenance times accordingly.
3. The tension of the V-belt should be adjusted during the initial stage (500H) and inspected every 2,500 hours afterwards. Proper belt tension for 1 to 3 HP units is 2-3 lbs./0.5 inch deflection; for 5 to 15 HP units, 4-6 lbs./0.5 inch deflection.



**Troubleshooting Guide**

<b>PROBLEM</b>	<b>CAUSE</b>	<b>CORRECTIVE ACTION</b>
No voltage at terminal block	1. Main disconnect is not ON 2. Blown fuse or circuit breaker at customer provided power supply	1. Switch disconnect to ON 2. Inspect for any fault replace fuse or trip disconnect to ON
Voltage at terminal block, but compressor will not run	1. Motor overload has tripped 2. Wrong or low voltage 3. Starter has failed 4. Motor has failed 5. Drive belts came off or too loose	1. See last entry of Troubleshooting Guide 2. Check incoming power supply and unit power rating 3. Replace contactor assembly 4. Replace motor 5. Replace drive belts and (or) tighten
Compressor is running but will not make pressure	1. Clogged intake filter element 2. Pressure relief valve has opened 3. Excessive piston ring wear 4. Electric tank drain is open continuously 5. Discharge air is leaking 6. Receiver is leaking	1. Replace intake filter element 2. Pressure switch or starter contacts should be inspected/replaced 3. Replace piston rings 4. Replace tank drain 5. Check discharge piping 6. Replace receiver
Excessive noise or vibration	1. Drive belt has separated or flat spot 2. Motor has failed 3. Pump is damaged 4. Cooling air fan is touching fan guard	1. Replace drive belt 2. Replace motor 3. Fix or replace pump 4. Check air fan for cause of interference
Compressor shuts down on high temperature (when optional high temp shutdown is ordered)	1. Room temperature is above 104° F 2. Inlet air duct is obstructed 3. Unit running in the wrong direction 4. Aftercooler fins clogged 5. Intake filter damaged 6. Compressor is dirty 7. Altitude affecting compressor performance	1. Add ventilation or air conditioning to room 2. Remove obstruction or reposition unit to allow for cooling air 3. Correct power connections 4. Clean aftercooler 5. Check intake filter 6. Clean unit 7. Call Powerex for assistance
Compressor turns on/off rapidly	1. Receiver tank has high level of water 2. Compressor check valve has failed 3. Defective pressure switch	1. Replace electric tank drain/drain tank 2. Replace check valve 3. Replace pressure switch
Safety valves blows off	1. Pressure switch has failed to open 2. Motor starter contacts welded shut 3. Safety valve blows off at too low of pressure	1. Replace pressure switch 2. Replace motor starter 3. Replace safety valve
Motor Overload has tripped	1. Pump has failed 2. Motor has failed 3. Improper wiring size 4. Wrong overload setting 5. Low voltage	1. Fix or replace pump 2. Replace motor 3. Check wiring 4. Check overload setting 5. Check incoming power supply
Pressure switch unloader or solenoid unloader constantly bleeds air after compressor shuts off	1. Check valve has failed 2. Unloader mechanism has failed	1. Replace check valve, bleed all air from tank before replacing 2. Replace unloader mechanism

---

**Powerex Limited Warranty – Applicable to Non-OEM Customers in the U.S. & Canada Only**

**Warranty and Remedies.**

**(a) General.** Powerex warrants each Compressor System, Vacuum System, Vacuum Pump, Compressor Air-End, or Powerex branded Accessory (collectively “Products”, individually each a “Product”) to be free from defects in material and workmanship (“Defects”) at the date of shipment. This warranty shall apply only to Products that are purchased and used in the United States of America and in Canada. EXCEPT AS SET FORTH BELOW, NO OTHER WARRANTY, WHETHER EXPRESS OR IMPLIED, INCLUDING ANY WARRANTY OF MERCHANTABILITY OR FITNESS FOR A PARTICULAR PURPOSE, SHALL EXIST IN CONNECTION WITH THE SALE OR USE OF SUCH PRODUCTS. TO THE EXTENT PERMITTED BY LAW, ANY AND ALL IMPLIED WARRANTIES ARE EXCLUDED. All warranty claims must be made in writing and delivered to Powerex in accordance with the procedures set forth on its website (www.powerexinc.com), or such claim shall be barred. Upon timely receipt of a warranty claim, Powerex shall inspect the Product claimed to have a Defect, and Powerex shall repair, or, at its option, replace, free of charge, any Product which it determines to have had a Defect; provided, however, that if circumstances are such as to preclude the remedying of Defect by repair or replacement, Powerex shall, upon return of the Product, refund to buyer any part of the purchase price of such Products paid to Powerex. Freight for returning Products to Powerex for inspection shall be paid by buyer. The warranties and remedies herein are the sole and exclusive remedy for any breach of warranty or for any other claim based on any Defect, or non-performance of the Products, whether based upon contract, warranty or negligence.

**(b) (i) Standard Period of Warranty – Parts and Labor** - The purchase of any system includes our standard warranty. Powerex warrants and represents all Products shall be free from Defects for the first eighteen (18) months from the date of shipment by Powerex, or twelve (12) months from the documented date of startup, or five thousand (5,000) hours of use, whichever occurs first. During such warranty period, Powerex shall be fully liable for all Defects in the Products (the “Product Defects”), i.e., all costs of repair or replacement, which may include “in and out” charges, so long as the Products are located in the United States or Canada, and the Products are reasonably located and accessible by service personnel for removal. “In and out” charges include the costs of removing a Product from buyer’s equipment for repair or replacement.

**(ii) Premium Period of Warranty – Parts and Labor** - In order to be eligible for premium warranty coverage, a premium warranty for each system must be purchased when order is placed. Powerex warrants and represents all Products shall be free from Defects for the first thirty (30) months from the date of shipment by Powerex, or twenty-four (24) months from the documented date of startup, or seven thousand five hundred (7,500) hours of use, whichever occurs first. During such warranty period, Powerex shall be fully liable for all Defects in the Products (the “Product Defects”), i.e., all costs of repair or replacement, which may include “in and out” charges, so long as the Products are located in the United States or Canada, and the Products are reasonably located and accessible by service personnel for removal. “In and out” charges include the costs of removing a Product from buyer’s equipment for repair or replacement.

**(c) Additional Period of Warranty – Parts Only (No Labor).** In addition to the above, Powerex warrants each Powerex branded Compressor Air- End and Vacuum Pump shall be free of Defects for a period of forty-two (42) months from the date of shipment by Powerex, or thirty-six (36) months from the documented date of startup, or ten thousand (10,000) hours of use, whichever occurs first. Supplier’s repair or replacement of any Product shall not extend the period of any warranty of any Product. This warranty applies to the exchange of part(s) found to be defective by an Authorized Powerex Service Representative only.

**(d) Replacement Pumps – Parts Only (No Labor).** For any replacement Air-End or Vacuum Pumps installed on a Powerex manufactured system or unit after any initial warranty period has expired or where another warranty does not apply for any reason, Powerex warrants that the Air-End or Vacuum Pumps shall be free of Defects for a period of thirty-six (36) months from the date of shipment by Powerex or ten thousand (10,000) hours of use, whichever comes first. For any replacement Air-End or Vacuum Pumps installed on a system that was not manufactured by Powerex after any initial warranty period has expired or where another warranty does not apply for any reason, Powerex warrants that the Air-End or Vacuum Pumps shall be free of Defects for the first twelve (12) months from the date of shipment by Powerex. Supplier’s repair or replacement of any Product shall not extend the period of any warranty of any Product. This warranty applies to the exchange of part(s) found to be defective by an Authorized Powerex Service Representative only.

**(e) Replacement Motors – Parts Only (No Labor).** For any replacement motor installed on a Powerex manufactured system or unit after any initial warranty period has expired or where another warranty does not apply for any reason, Powerex warrants that the replacement motor shall be free of Defects for the first twelve (12) months from the date of shipment by Powerex. For any replacement motor installed on a system or unit that was not manufactured by Powerex after any initial warranty period has expired or where another warranty does not apply for any reason, Powerex warrants that the replacement motor shall be free of Defects for the first ninety (90) days from the date of shipment by Powerex. Supplier’s repair or replacement of any Product shall not extend the period of any warranty of any Product. This warranty applies to the exchange of part(s) found to be defective by an Authorized Powerex Service Representative only.

**(f) Replacement Parts – Parts Only (No Labor).** For other replacement parts besides motors, Air-End or Vacuum Pumps installed on a Powerex manufactured system or unit after any initial warranty period has expired or where another warranty does not apply for any reason, Powerex warrants that such replacement parts will be free from Defects for the first twelve (12) months from the date of shipment by Powerex. For other replacement parts besides motors, Air-End or Vacuum Pumps installed on a system or unit that was not manufactured by Powerex after any initial warranty period has expired or where another warranty does not apply for any reason, Powerex makes no warranties. Supplier’s repair or replacement of any Product shall not extend the period of any warranty of any Product. This warranty applies to the exchange of part(s) found to be defective by an Authorized Powerex Service Representative only.

**(g) Coverage.** The warranty provided herein applies to Powerex manufactured units or systems only.

**(h) Exceptions.** Notwithstanding anything to the contrary herein, Powerex shall have no warranty obligations with respect to Products:

- (i) that have not been installed in accordance with Powerex’s written specifications and instructions;
- (ii) that have not been maintained in accordance with Powerex’s written instructions;
- (iii) that have been materially modified without the prior written approval of Powerex; or
- (iv) that experience failures resulting from operation, either intentional or otherwise, in excess of rated capacities or in an otherwise improper manner.

## ***Oilless Tankmount Simplex***

---

(i) The warranty provided herein shall not apply to:

- (i) any defects arising from corrosion, abrasion, use of insoluble lubricants, or negligent attendance to or faulty operation of the Products;
- (ii) ordinary wear and tear of the Products;
- (iii) defects arising from abnormal conditions of temperature, dirt or corrosive matter; or
- (iv) any OEM component which is shipped by Powerex with the original manufacturer's warranty, which shall be the sole applicable warranty for such component.

**Limitation of Liability.** NOTWITHSTANDING ANYTHING TO THE CONTRARY HEREIN, TO THE EXTENT ALLOWABLE UNDER APPLICABLE LAW, UNDER NO CIRCUMSTANCES SHALL POWEREX BE LIABLE FOR ANY INCIDENTAL, CONSEQUENTIAL, PUNITIVE, SPECULATIVE OR INDIRECT LOSSES OR DAMAGES WHATSOEVER ARISING OUT OF OR IN ANY WAY RELATED TO ANY OF THE PRODUCTS OR GOODS SOLD OR AGREED TO BE SOLD BY POWEREX TO BUYER. TO THE EXTENT ALLOWABLE UNDER APPLICABLE LAW, POWEREX'S LIABILITY IN ALL EVENTS IS LIMITED TO, AND SHALL NOT EXCEED, THE PURCHASE PRICE PAID.

**Warranty Disclaimer.** Powerex has made a diligent effort to illustrate and describe the Products in its literature, including its Price Book, accurately; however, such illustrations and descriptions are for the sole purpose of identification, and do not express or imply a warranty that the Products are merchantable, or fit for a particular purpose, or that the Products will necessarily conform to the illustrations or descriptions.

**Product Suitability.** Many jurisdictions have codes and regulations governing sales, construction, installation, and/or use of Products for certain purposes, which may vary from those in neighboring areas. While Powerex attempts to assure that its Products comply with such codes, it cannot guarantee compliance, and cannot be responsible for how the product is installed or used. Before purchase and use of a Product, please review the Product applications, and national and local codes and regulations, and be sure that the Product, installation, and use will comply with them.

**Claims.** Any non-warranty claims pertaining to the Products must be filed with Powerex within 6 months of the invoice date, or they will not be honored. Prices, discounts, and terms are subject to change without notice or as stipulated in specific Product quotations. Powerex shall not be liable for any delay or failure arising out of acts of the public enemy, fire, flood, or any disaster, labor trouble, riot or disorder, delay in the supply of materials or any other cause, whether similar or dissimilar, beyond the control of Company. All shipments are carefully inspected and counted before leaving the factory. Please inspect carefully any receipt of Products noting any discrepancy or damage on the carrier's freight bill at the time of delivery. Discrepancies or damage which obviously occurred in transit are the carrier's responsibility and related claims should be made promptly directly to the carrier. Returned Products will not be accepted without prior written authorization by Powerex and deductions from invoices for shortage or damage claims will not be allowed. **UNLESS OTHERWISE AGREED TO IN WRITING, THE TERMS AND CONDITIONS CONTAINED IN THIS LIMITED WARRANTY WILL CONTROL IN ANY TRANSACTION WITH POWEREX.** Any different or conflicting terms as may appear on any order form now or later submitted by the buyer will not control. All orders are subject to acceptance by Powerex.