

UTILITY REQUIREMENTS

MODEL	PRESSURE	NAMEPLATE HORSEPOWER	COOLING FAN OUTPUT CFM	HEAT REJECTION TO AIR BTU/MIN	APPROX. POWER CONSUMPTION kW	APPROX. SHIPPING WEIGHT LB
A/H	125 PSIG (OPERATING)	50	6500	2350	45	3670
	150 PSIG (MAX WORKING)		6500	2620	50	
B/L	100 PSIG (OPERATING)	50	6500	2590	49	3670
	125 PSIG (OPERATING)		6500	2900	55	
B/H	100 PSIG (OPERATING)	60	6500	3210	60	3740
	125 PSIG (OPERATING)		6500	3160	59	
C/L	100 PSIG (OPERATING)	60	6500	3540	66	3880
	125 PSIG (OPERATING)		6500	3940	73	
C/H	100 PSIG (OPERATING)	75	6500	3580	67	3880
	125 PSIG (OPERATING)		6500	4020	74	
D/L	100 PSIG (OPERATING)	75	6500	4200	77	3910
	125 PSIG (OPERATING)		6500	4200	77	
D/H	125 PSIG (OPERATING)	100	6500	4420	81	3910
	135 PSIG (MAX WORKING)		6500	4420	81	
E/L	100 PSIG (OPERATING)	100	6500	4420	81	3910

ELECTRICAL REQUIREMENTS: 3Ø, 60Hz, 480V

- NOTES**
 1. PERFORMANCE DATA SHOWN IS FOR STANDARD CONDITIONS OF AMBIENT PRESSURE 14.5 PSIA, AMBIENT TEMPERATURE 80°F, RELATIVE HUMIDITY 60%. OPERATION IN OTHER CONDITIONS WILL AFFECT PERFORMANCE.
 2. VALUES WILL VARY ±4% FOR CAPACITY AND ±5% FOR SPECIFIC POWER.

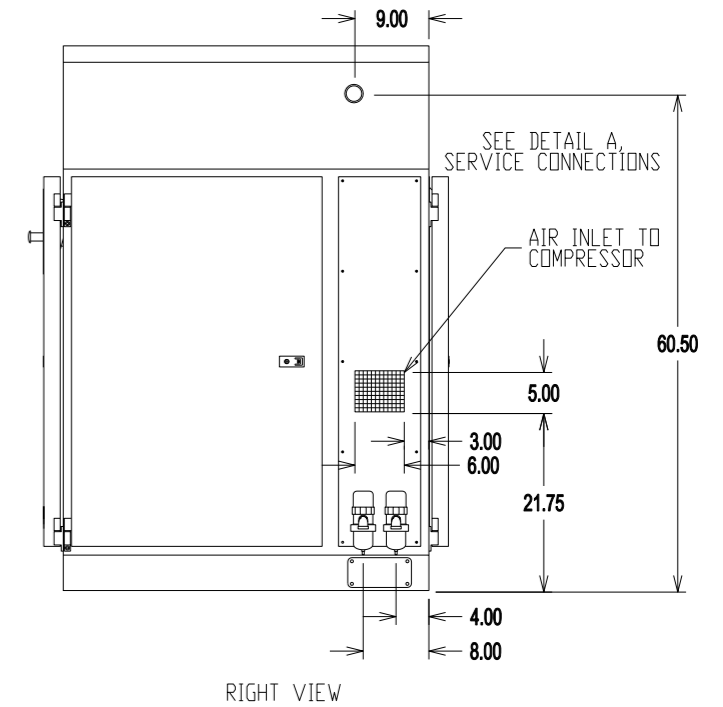
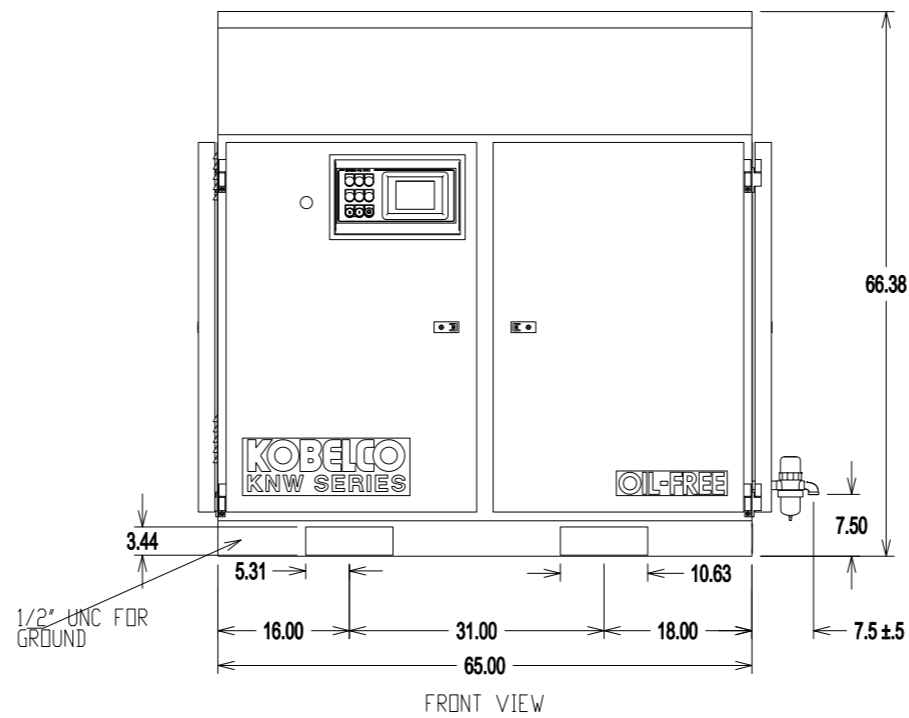
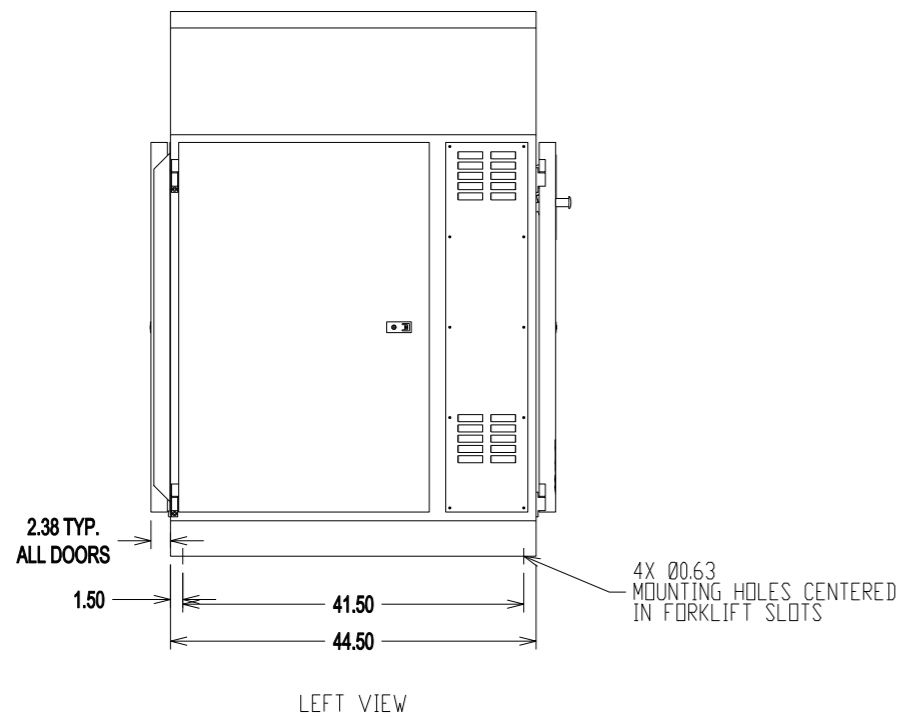
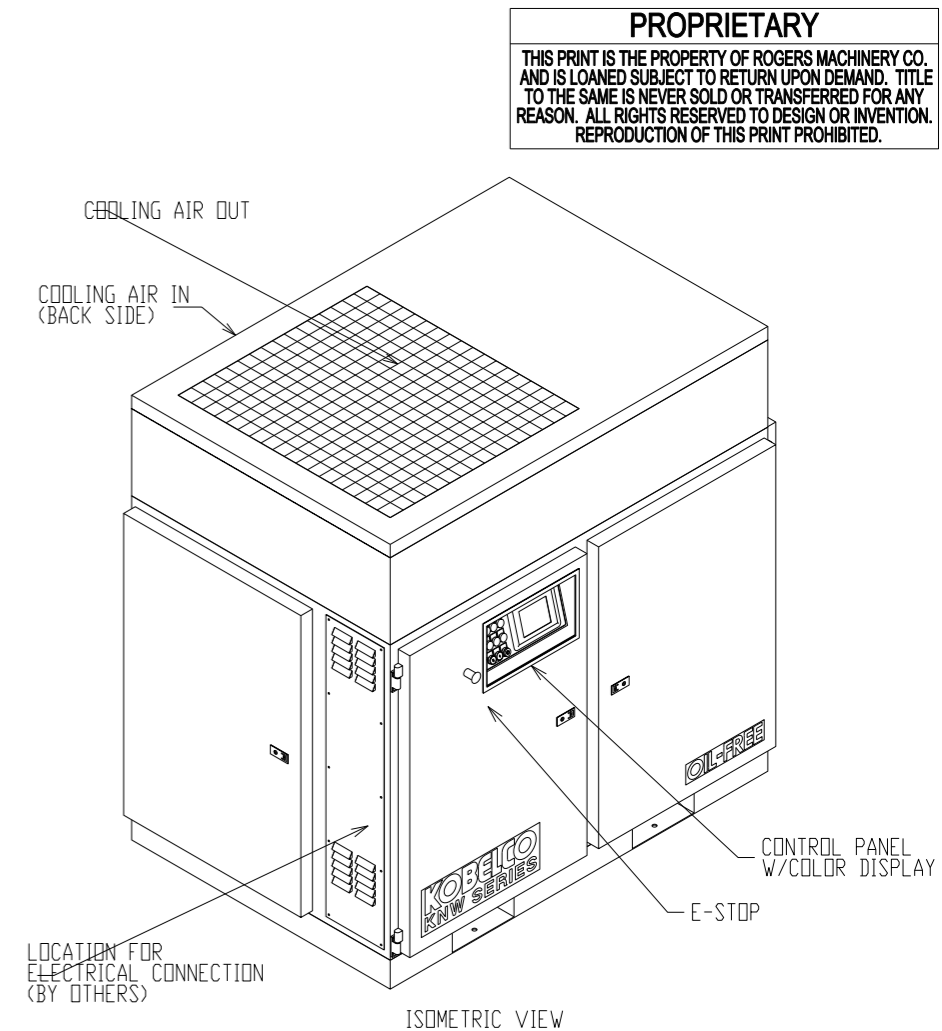
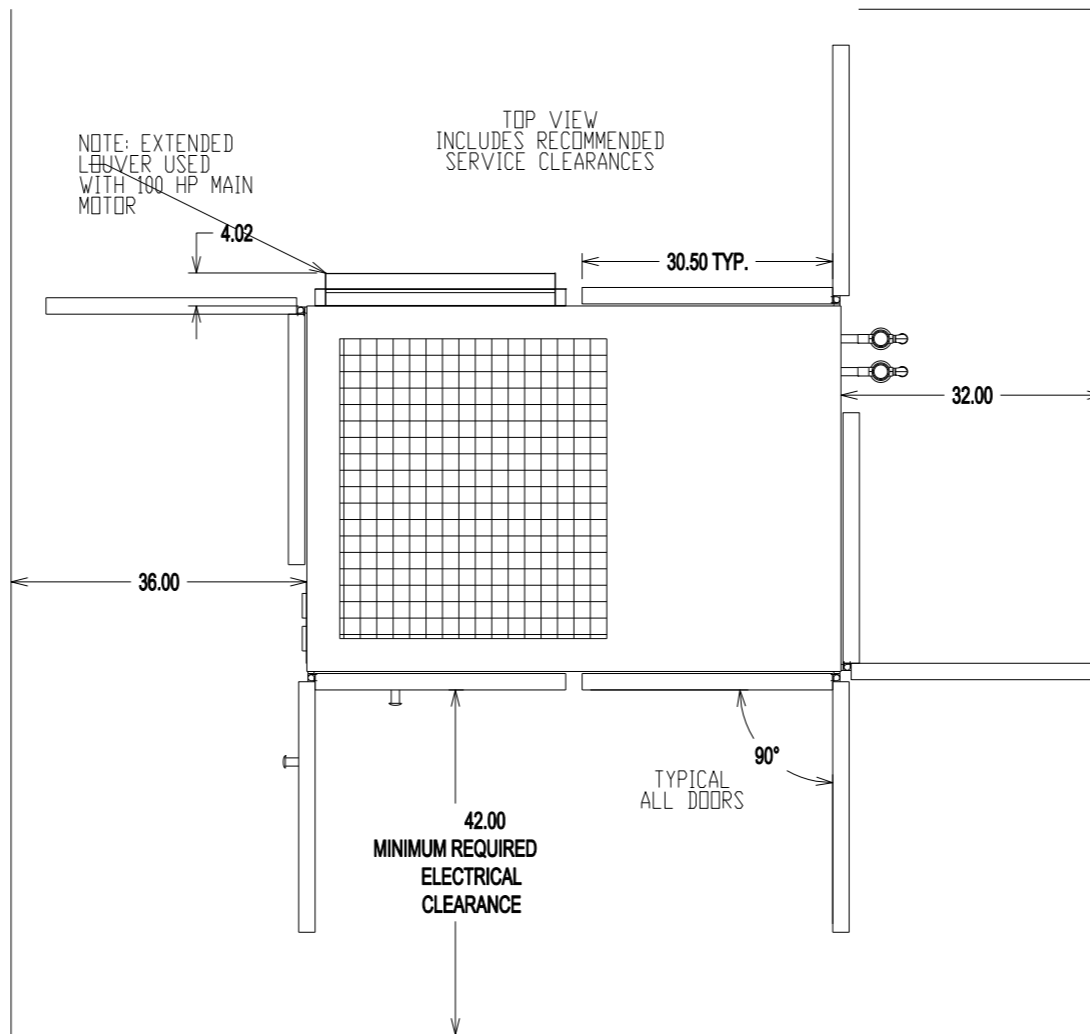
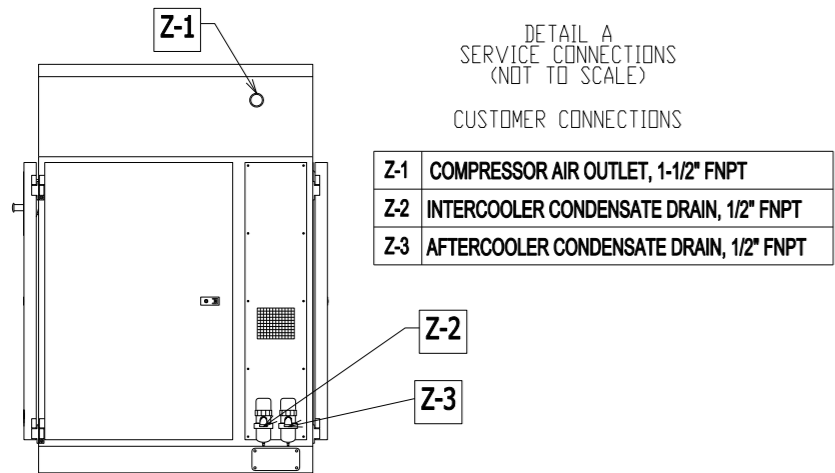

DIMENSIONS ARE IN INCHES UNLESS OTHERWISE NOTED

REV	DATE	BY	CK	DESCRIPTION

DRAWN	G.E. WILKER	05DEC13
CHECKED		
SIZE	B	SCALE 1:24
SERIAL#	POWEREX - TBD	

COMPRESSOR ASSEMBLY
 KOBELCO KNW SERIES AIR COMPRESSOR
 MODEL KNWA0, AIR-COOLED
 WYE-DELTA STARTER, STANDARD ASSEMBLY

DRAWING NUMBER
K00754A.0
 SHEET 1 OF 1

GALLONS	SIZE	DESIGN PRESSURE	WEIGHT lbs.	DESCRIPTION
400	36 x 101	165 PSI	880	ASME VERTICAL INDUSTRIAL w/BASE RING

REV	ZONE	REVISION	DATE	ECN	NAME	CHKD
A-1	ALL	SUBMITTAL DRAWINGS	8/7/13	PKEC0052	RK	AEK
B-1	ALL	RELEASE FOR PRODUCTION	8/7/13	PKEC0052	RK	AEK
C-1	ALL	CHANGED TANK PSI FROM 200 TO 165	04/26/18	PKEC0229	DMS	GES

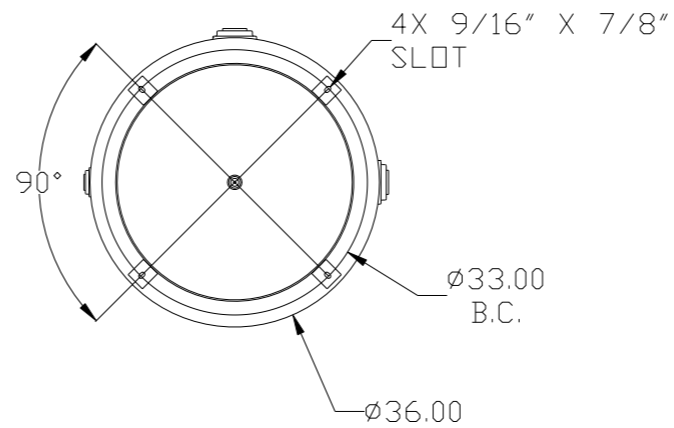
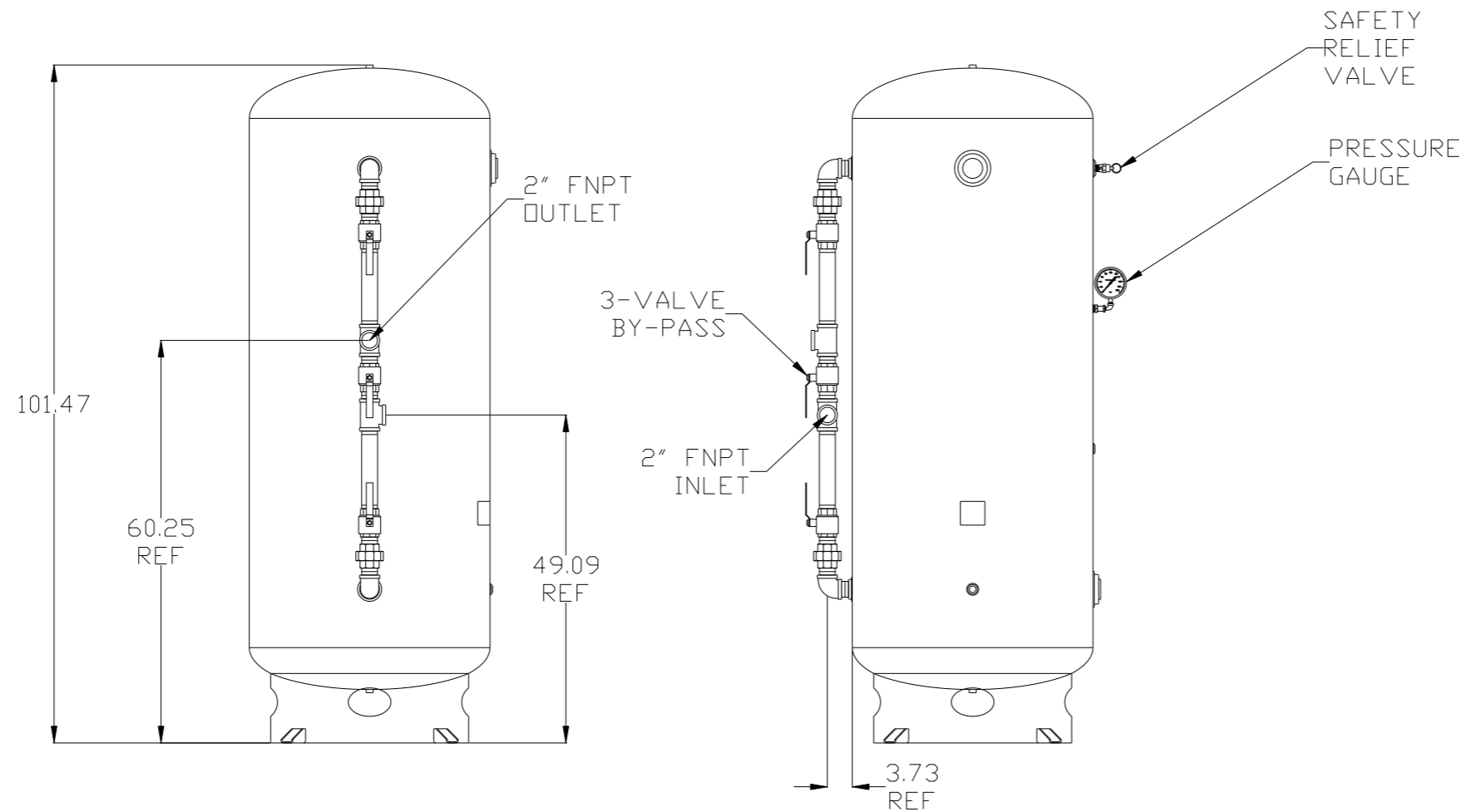

- NOTES:
 1) ASME CERTIFIED VESSEL
 2) ALL DIMENSIONS ARE REFERENCE DIMENSIONS
 3) APPROXIMATE WT. - 880 LBS.

SYMBOL LEGEND ⊖ = MINUS DRAFT ⊕ = PLUS DRAFT TOLERANCES NOT SPECIFIED .XX ± .XXX ± \angle (DEG.) ±		= ADDITIONAL CONTROL REQ'D = BRINELL HARDNESS		Drawings to conform to the current revision of the following ANSI standards: Y14.3 Multi- and sectional view deqs Y14.5M Dimensioning and tolerancing
AUTOCAD REL2008 LT INCH		DO NOT SCALE DRAWING FOR DIMENSIONS Sheet 2 of 5 SCALE 1:12		
CONFIDENTIAL DISCLOSURE This drawing is the property of POWEREX, INC. of the SCOTT FETZER COMPANY and subject to return on demand. Its contents are confidential and must not be copied or submitted to outside parties for use or examination.				
DRAWN BY RK	CHECKED BY AEK	APPROVED BY JA	MFG/MRKTG CT	
8/6/13	8/7/13	8/7/12	8/7/12	
MATERIAL N/A		 150 PRODUCTION DRIVE, HARRISON, OHIO 45030 Ph: 888-769-7979 FAX: (513) 367-3125		
PART NAME 40-100HP VFD TRIPLEX ENCLOSED COMPRESSOR		DWG NO LTRE0757	SIZE D	

REV	ZONE	REVISION	DATE	ECN	NAME	CHKD
A-1	ALL	SUBMITTAL DRAWINGS	8/7/13	PXEC0052	RK	AEK
B-1	ALL	RELEASE FOR PRODUCTION	8/7/13	PXEC0052	RK	AEK
C-1	ALL	CHANGED TANK PSI FROM 200 TO 165	04/26/18	PXEC0029	DMS	GES

MINIMUM RECOMMENDED
ELECTRICAL PANEL
CLEARANCE PER OSHA/
NEC REQUIREMENTS

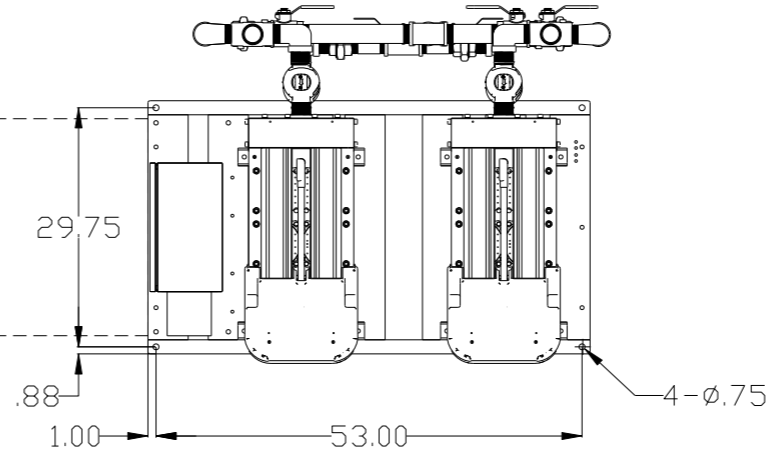

2X DESICCANT AIR DRYER
W/ PRE-FILTER, AFTER-FILTER,
& CHARCOAL FILTER (OPTIONAL).

DEW POINT
MONITOR
CO MONITOR
(OPTIONAL)

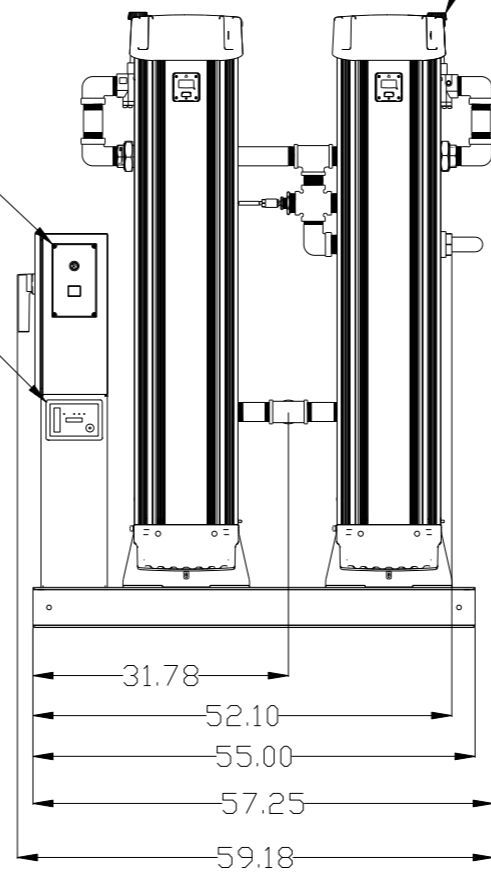
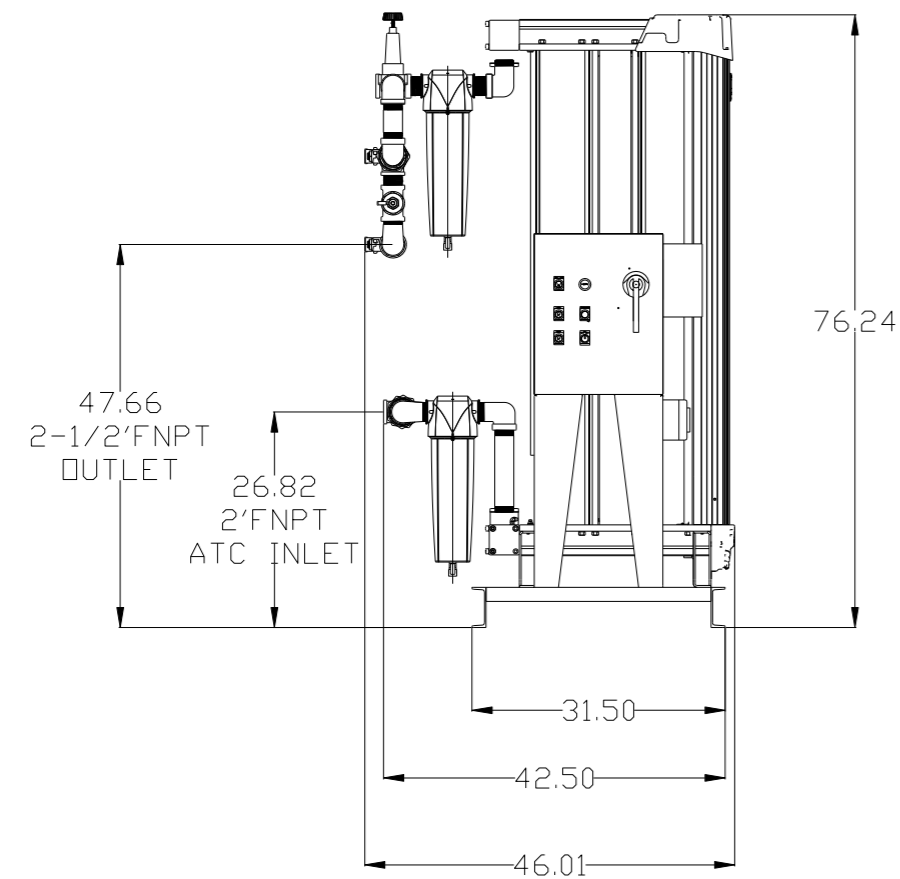

SYMBOL LEGEND ⊖ = MINUS DRAFT ⊕ = PLUS DRAFT ⊕ = ADDITIONAL CONTROL REQ'D ⊕ = BRINELL HARDNESS		Drawings to conform to the current revision of the following ANSI standards: Y14.3 Multi and sectional view dsgs. Y14.5M Dimensioning and tolerancing															
TOLERANCES NOT SPECIFIED .XX ± .XXX ± ∠(DEG.) ±	AUTOCAD REL2008 LT INCH	DO NOT SCALE DRAWING FOR DIMENSIONS Sheet 3 of 5 SCALE 1:12															
CONFIDENTIAL DISCLOSURE This drawing is the property of POWEREX, INC. of the SCOTT FETZER COMPANY and subject to return on demand. Its contents are confidential and must not be copied or submitted to outside parties for use or examination.		<table border="1"> <tr> <th>DRAWN BY</th> <th>CHECKED BY</th> <th>APPROVED BY</th> <th>ENGINEERING</th> <th>MFG/MRKTG</th> </tr> <tr> <td>RK</td> <td>AEK</td> <td>JA</td> <td>CT</td> <td></td> </tr> <tr> <td>8/6/13</td> <td>8/7/13</td> <td>8/7/12</td> <td>8/7/12</td> <td></td> </tr> </table>	DRAWN BY	CHECKED BY	APPROVED BY	ENGINEERING	MFG/MRKTG	RK	AEK	JA	CT		8/6/13	8/7/13	8/7/12	8/7/12	
DRAWN BY	CHECKED BY	APPROVED BY	ENGINEERING	MFG/MRKTG													
RK	AEK	JA	CT														
8/6/13	8/7/13	8/7/12	8/7/12														
MATERIAL N/A		 150 PRODUCTION DRIVE, HARRISON, OHIO 45030 Ph: 888-769-7979 FAX: (513) 367-3125															
PART NAME DRYER PACKAGE SKID																	
DVG NO 55" X 31.5"		SIZE LTRE0757 D															

REV	ZONE	REVISION	DATE	ECN	NAME	CHKD
A-1	ALL	SUBMITTAL DRAWINGS	8/7/13	PXC0052	RK	AEK
B-1	ALL	RELEASE FOR PRODUCTION	8/7/13	PXC0052	RK	AEK
C-1	ALL	CHANGED TANK PSI FROM 200 TO 165	04/26/18	PXC0289	DMS	GES

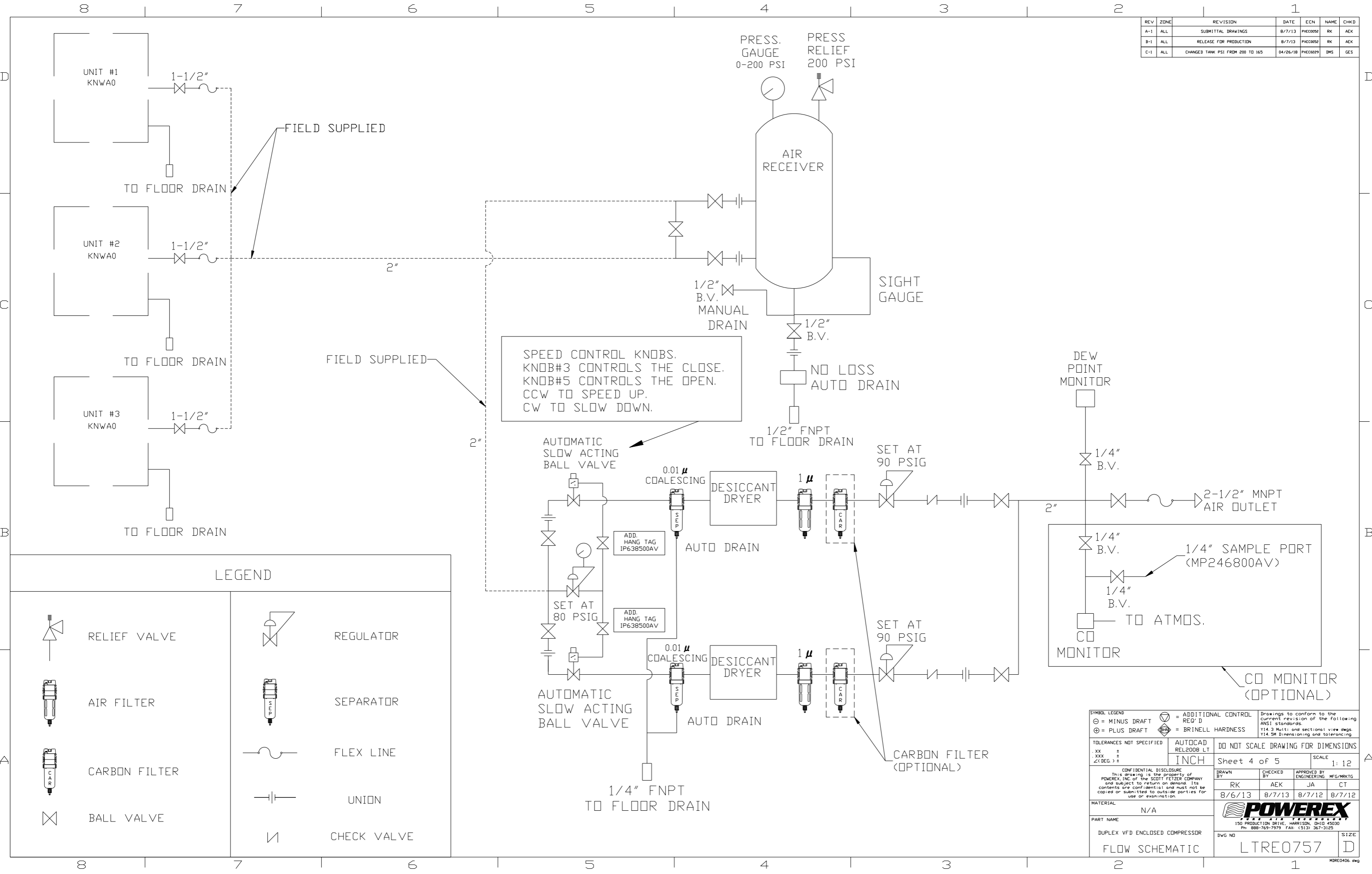

SPEED CONTROL KNOBS.
 KNOB#3 CONTROLS THE CLOSE.
 KNOB#5 CONTROLS THE OPEN.
 CCW TO SPEED UP.
 CW TO SLOW DOWN.

1/4" SAMPLE PORT
 (MP246800AV)

TO ATMOS.

CO MONITOR
 (OPTIONAL)

LEGEND	
	RELIEF VALVE
	AIR FILTER
	CARBON FILTER
	BALL VALVE
	REGULATOR
	SEPARATOR
	FLEX LINE
	UNION
	CHECK VALVE

SYMBOL LEGEND		= ADDITIONAL CONTROL REQ'D		Drawings to conform to the ANSI standards.	
⊖ = MINUS DRAFT		⊕ = BRINELL HARDNESS		Y14.3 Multi- and sectional view dep.	
⊕ = PLUS DRAFT				Y14.5M Dimensioning and tolerancing	
TOLERANCES NOT SPECIFIED		AUTOCAD REL2008 LT		DO NOT SCALE DRAWING FOR DIMENSIONS	
.XX ±		INCH		Sheet 4 of 5	
.XXX ±				SCALE 1:12	
<DEG> ±					
CONFIDENTIAL DISCLOSURE					
This drawing is the property of POWEREX, INC. of the SCOTT FETZER COMPANY and subject to return on demand. Its contents are confidential and must not be copied or submitted to outside parties for use or examination.					
DRAWN BY		CHECKED BY		APPROVED BY	
RK		AEK		JA CT	
8/6/13		8/7/13		8/7/12 8/7/12	
MATERIAL N/A					
PART NAME					
DUPLX VFD ENCLOSED COMPRESSOR					
FLOW SCHEMATIC					
DWG NO				SIZE	
LTRE0757				D	

REV	ZONE	REVISION	DATE	ECN	NAME	CHKD
A-1	ALL	SUBMITTAL DRAWINGS	8/7/13	PXC0052	RK	AEK
B-1	ALL	RELEASE FOR PRODUCTION	8/7/13	PXC0052	RK	AEK
C-1	ALL	CHANGED TANK PSI FROM 200 TO 165	04/26/18	PXC0229	DMS	GES

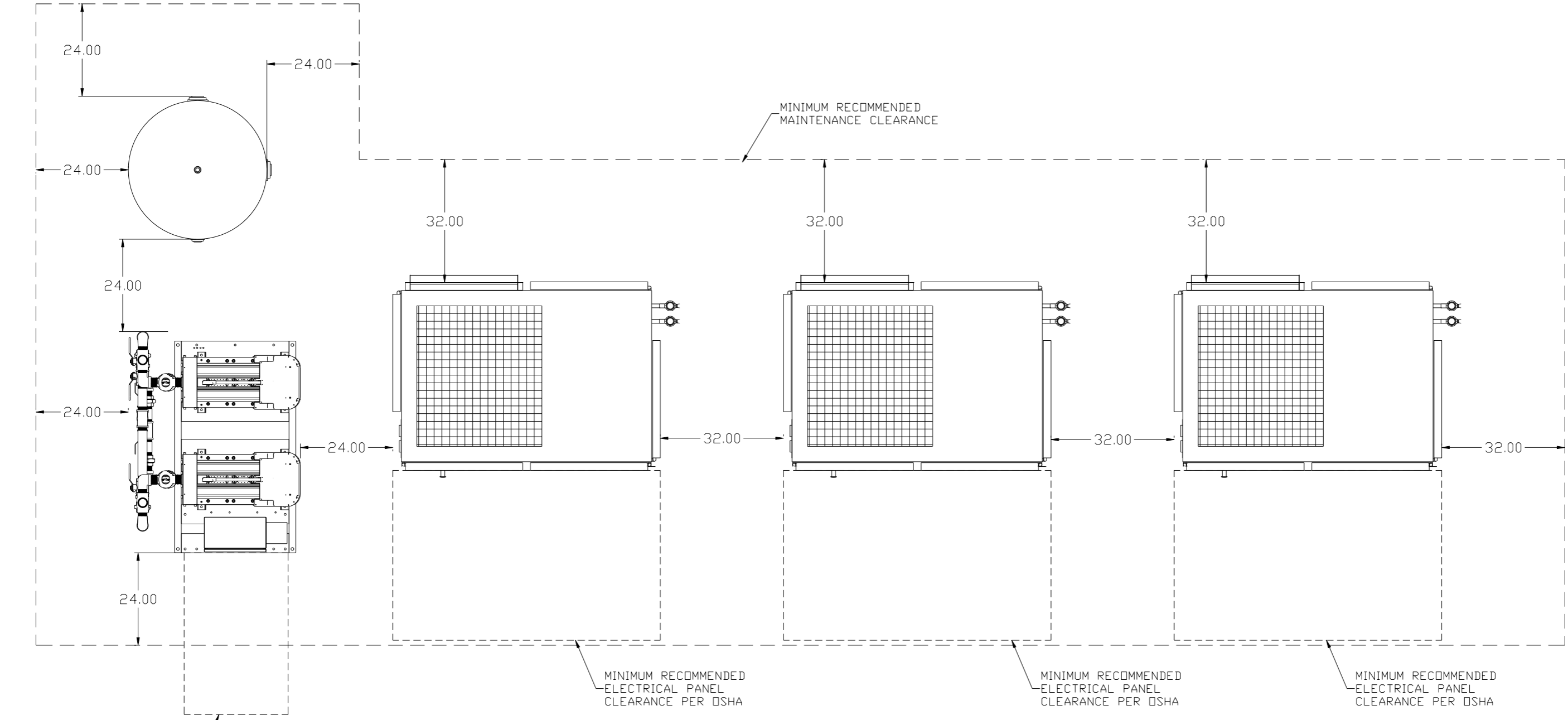

MINIMUM RECOMMENDED ELECTRICAL PANEL CLEARANCE PER OSHA/NEC REQUIREMENTS

SYMBOL LEGEND ⊖ = MINUS DRAFT ⊕ = PLUS DRAFT ⊕ = ADDITIONAL CONTROL REQ'D ⊕ = BRINELL HARDNESS		Drawings to conform to the current revision of the following ANSI standards: Y14.3 Multi and sectional view desg. Y14.5M Dimensioning and tolerancing	
TOLERANCES NOT SPECIFIED .XX ± .XXX ± < (DEG.) ±		AUTOCAD REL2008 LT INCH DO NOT SCALE DRAWING FOR DIMENSIONS Sheet 5 of 5 SCALE 1:12	
CONFIDENTIAL DISCLOSURE This drawing is the property of POWEREX, INC. of the SCOTT, FETZER COMPANY and subject to return on demand. Its contents are confidential and must not be copied or submitted to outside parties for use or examination.		DRAWN BY: RK CHECKED BY: AEK APPROVED BY: JA, CT 8/6/13 8/7/13 8/7/12 8/7/12	
MATERIAL: N/A PART NAME: 40-100HP VFD TRIPLEX ENCLOSED COMPRESSOR		 150 PRODUCTION DRIVE, HARRISBURG, OHIO 45030 Ph: 888-769-7979 FAX: (513) 367-3125	
DWG NO: INSTALLATION		SIZE: LTRE0757 D	