

UTILITY REQUIREMENTS

MODEL	PRESSURE	NAMEPLATE HORSEPOWER	COOLING FAN OUTPUT CFM	HEAT REJECTION TO AIR BTU/MIN	APPROX. POWER CONSUMPTION kW	APPROX. SHIPPING WEIGHT LB
A/H	125 PSIG (OPERATING)	50	6500	2350	45	3670
	150 PSIG (MAX WORKING)		6500	2620	50	
B/L	100 PSIG (OPERATING)	50	6500	2590	49	3670
	125 PSIG (OPERATING)		6500	2900	55	
B/H	125 PSIG (OPERATING)	60	6500	3210	60	3740
	150 PSIG (MAX WORKING)		6500	3160	59	
C/L	100 PSIG (OPERATING)	60	6500	3540	66	3740
	125 PSIG (OPERATING)		6500	3940	73	
C/H	125 PSIG (OPERATING)	75	6500	3580	67	3880
	150 PSIG (MAX WORKING)		6500	4020	74	
D/L	100 PSIG (OPERATING)	75	6500	4200	77	3910
	125 PSIG (OPERATING)		6500	4200	77	
D/H	125 PSIG (OPERATING)	100	6500	4420	81	3910
	135 PSIG (MAX WORKING)		6500	4420	81	
E/L	100 PSIG (OPERATING)	100	6500	4420	81	3910

ELECTRICAL REQUIREMENTS: 3Ø, 60Hz, 480V

NOTES

- PERFORMANCE DATA SHOWN IS FOR STANDARD CONDITIONS OF AMBIENT PRESSURE 14.5 PSIA, AMBIENT TEMPERATURE 80°F, RELATIVE HUMIDITY 60%. OPERATION IN OTHER CONDITIONS WILL AFFECT PERFORMANCE.
- VALUES WILL VARY ±4% FOR CAPACITY AND ±5% FOR SPECIFIC POWER.

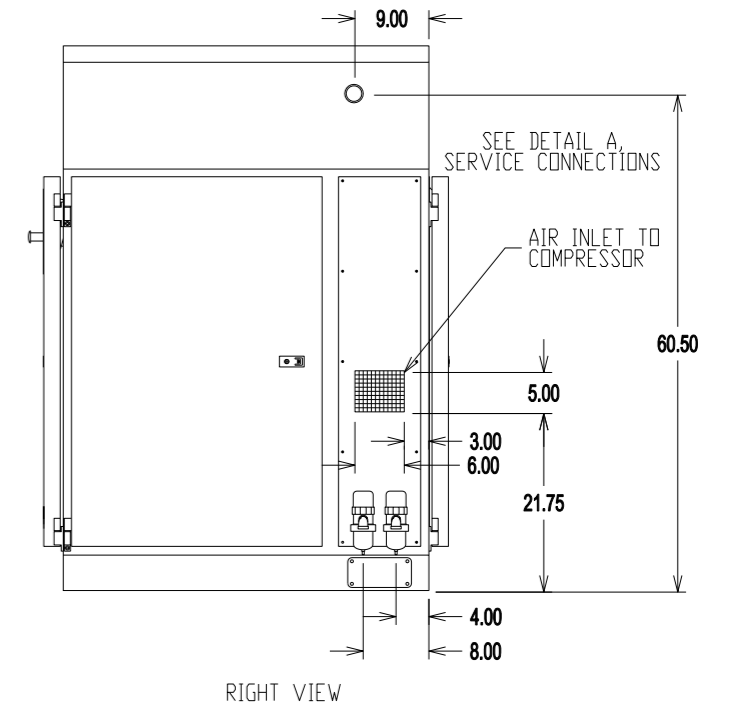
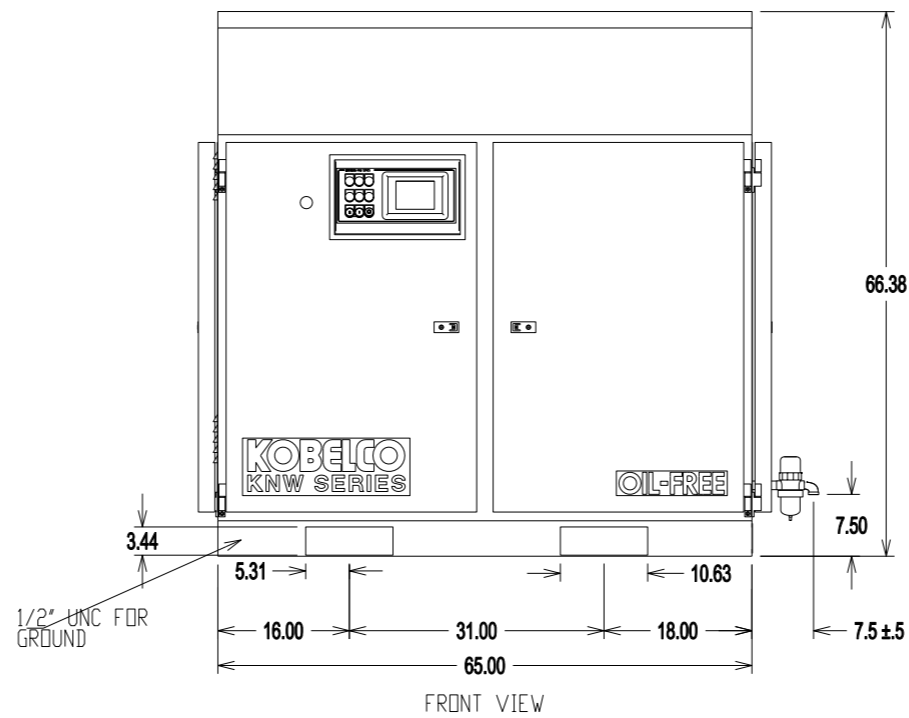
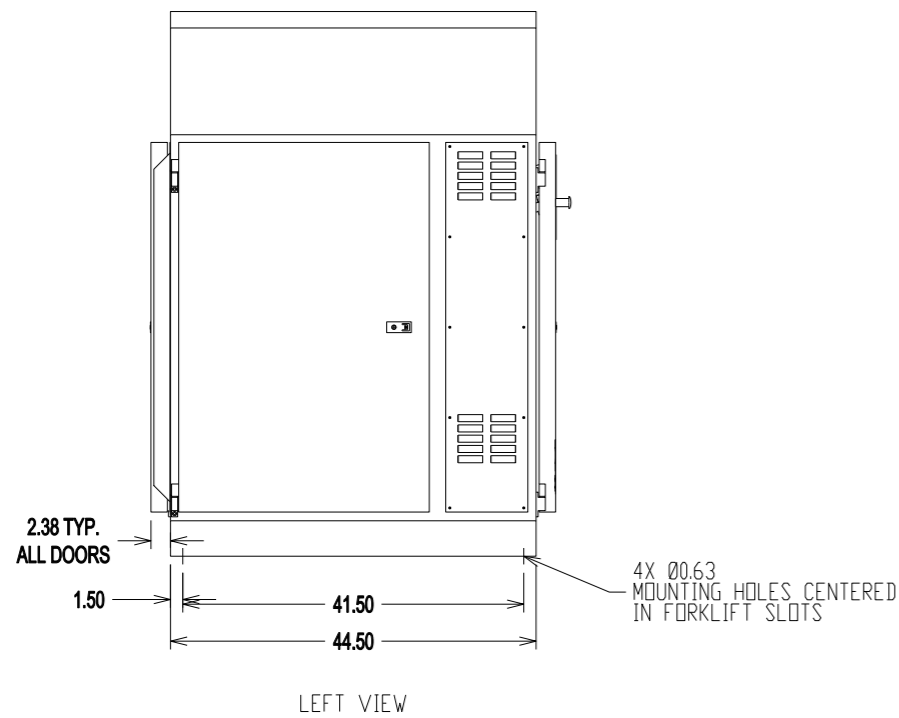
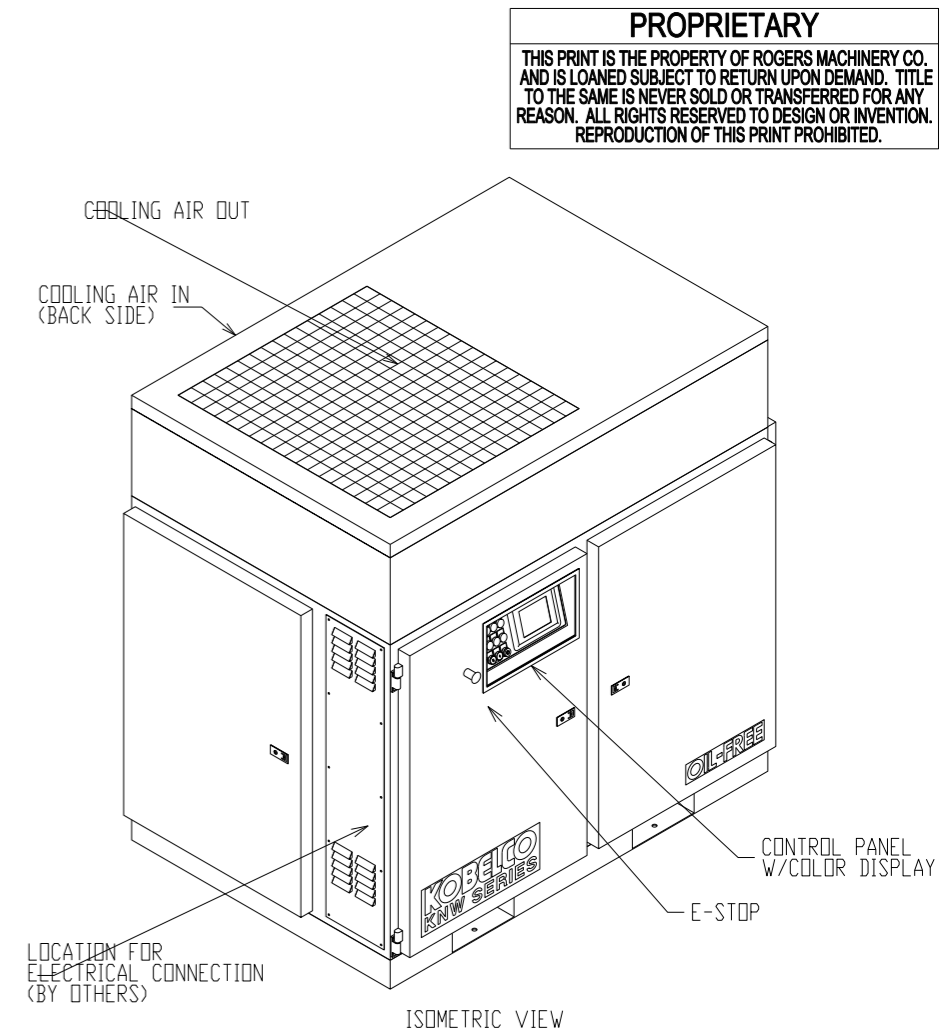
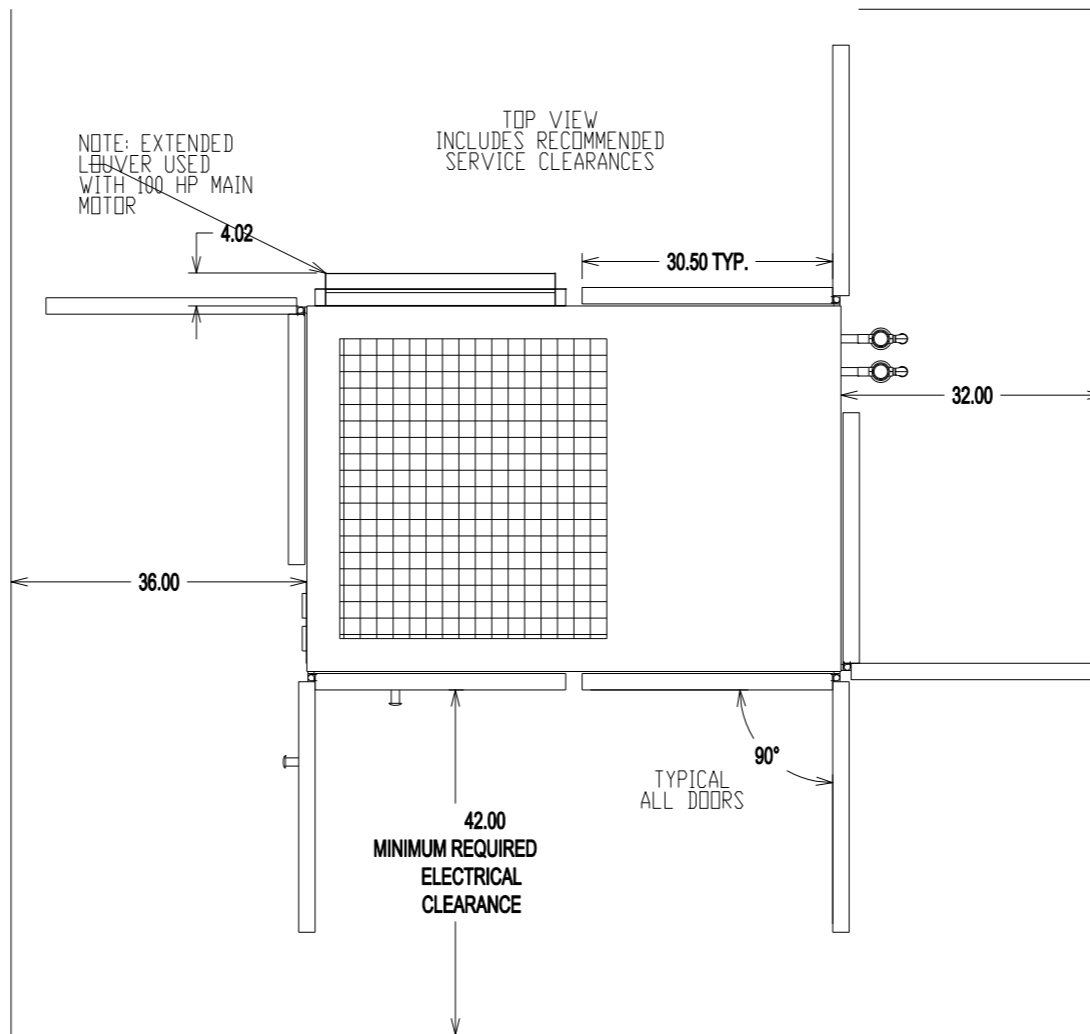
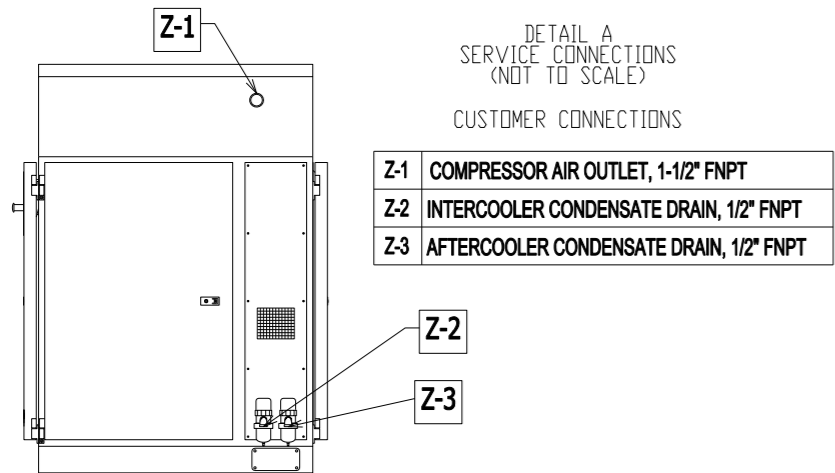

DIMENSIONS ARE IN INCHES UNLESS OTHERWISE NOTED

ROGERS MACHINERY COMPANY, INC.
 CORPORATE ENGINEERING
 14650 S.W. 72ND AVENUE
 PORTLAND, OREGON 97224
 www.rogers-machinery.com

REV	DATE	BY	CK	DESCRIPTION

DRAWN	G.E. WILKER	05DEC13
CHECKED		
SIZE	B	SCALE 1:24
SERIAL#	POWEREX - TBD	

COMPRESSOR ASSEMBLY
 KOBELCO KNW SERIES AIR COMPRESSOR
 MODEL KNWA0, AIR-COOLED
 WYE-DELTA STARTER, STANDARD ASSEMBLY

DRAWING NUMBER
K00754A.0
 SHEET 1 OF 1

GALLONS	SIZE	DESIGN PRESSURE	WEIGHT lbs.	DESCRIPTION
400	36 x 101	165 PSI	880	ASME VERTICAL INDUSTRIAL w/BASE RING

REV	ZONE	REVISION	DATE	ECN	NAME	CHKD
A-1	ALL	SUBMITTAL DRAWINGS	8/7/13	PKEC0052	RK	AEK
B-1	ALL	RELEASE FOR PRODUCTION	8/7/13	PKEC0052	RK	AEK
C-1	ALL	CHANGED TANK PSI FROM 200 TO 165	04/26/18	PKEC0029	DMS	GES

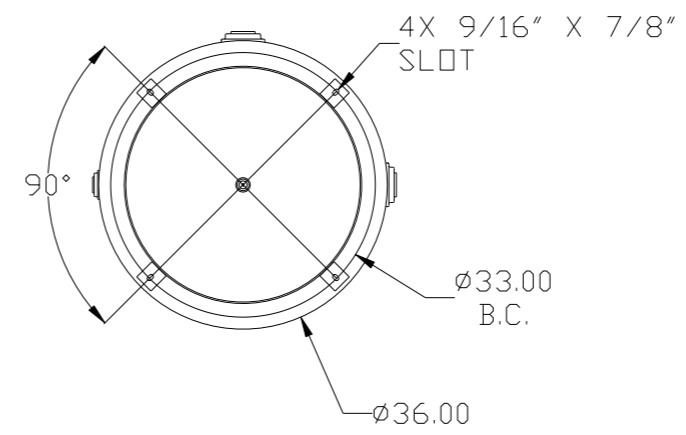
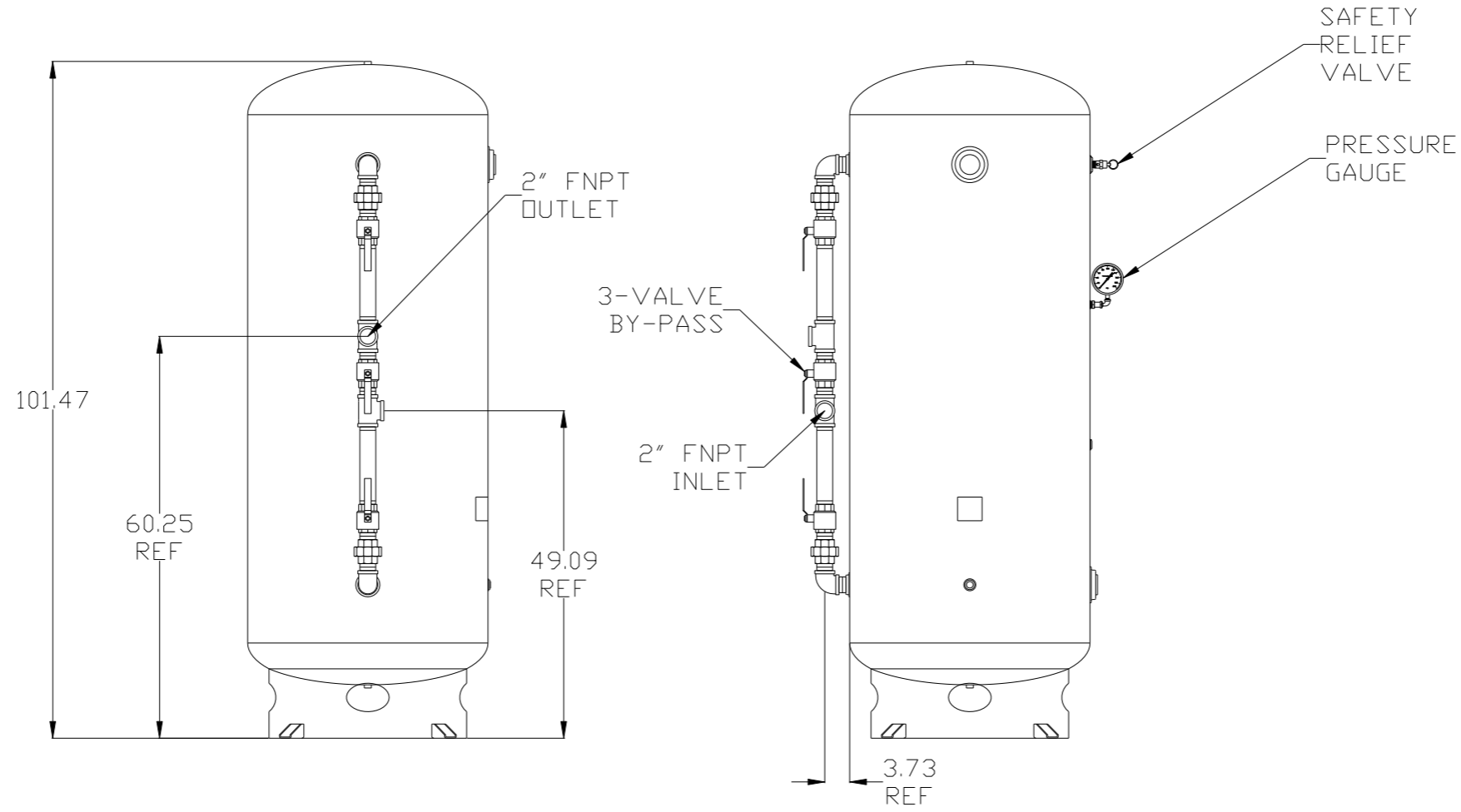

NOTES:
 1) ASME CERTIFIED VESSEL
 2) ALL DIMENSIONS ARE REFERENCE DIMENSIONS
 3) APPROXIMATE WT. - 880 LBS.

SYMBOL LEGEND ⊖ = MINUS DRAFT ⊕ = PLUS DRAFT ⊕ = ADDITIONAL CONTROL REQ'D ⊕ = BRINELL HARDNESS		Drawings to conform to the current revision of the following ANSI standards: Y14.3 Multi and sectional view dsgs Y14.5M Dimensioning and tolerancing	
TOLERANCES NOT SPECIFIED .XX ± .XXX ± <DEG> ±		DO NOT SCALE DRAWING FOR DIMENSIONS SCALE 1:12 Sheet 2 of 5	
CONFIDENTIAL DISCLOSURE This drawing is the property of POWEREX, INC. of the SCOTT FEITZER COMPANY and subject to return on demand. Its contents are confidential and must not be copied or submitted to outside parties for use or examination.		DRAWN BY: RK CHECKED BY: AEK APPROVED BY: JA, CT 8/6/13, 8/7/13, 8/7/12, 8/7/12	
MATERIAL: N/A		 150 PRODUCTION DRIVE, HARRISDN, OHIO 45030 Ph: 888-769-7979 FAX: (513) 367-3125	
PART NAME: 400-100HP VFD DUPLEX ENCLOSED COMPRESSOR		DWG NO: MDRE0757 SIZE: D	
400 GALLON DUAL DESICCANT PACKAGE		MRE0406.dwg	

REV	ZONE	REVISION	DATE	ECN	NAME	CHKD
A-1	ALL	SUBMITTAL DRAWINGS	8/7/13	PKEC0052	RK	AEK
B-1	ALL	RELEASE FOR PRODUCTION	8/7/13	PKEC0052	RK	AEK
C-1	ALL	CHANGED TANK PSI FROM 200 TO 165	04/26/18	PKEC0829	DMS	GES

MINIMUM RECOMMENDED
ELECTRICAL PANEL
CLEARANCE PER OSHA/
NEC REQUIREMENTS

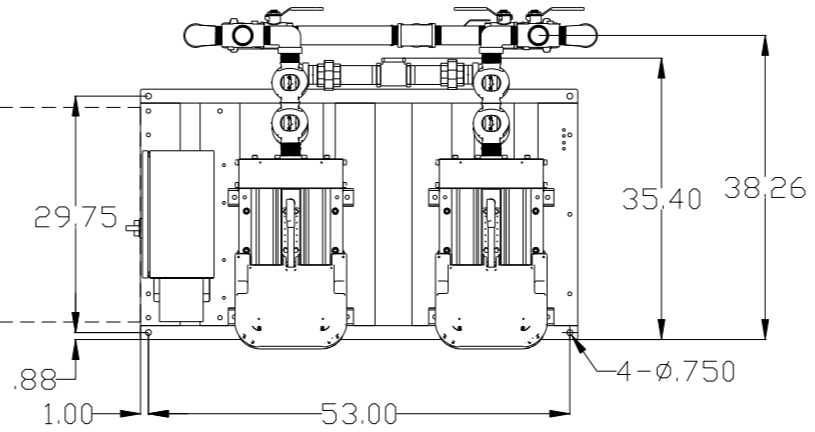

2X DESICCANT AIR DRYER
W/ PRE-FILTER, AFTER-FILTER,
& CHARCOAL FILTER (OPTIONAL).

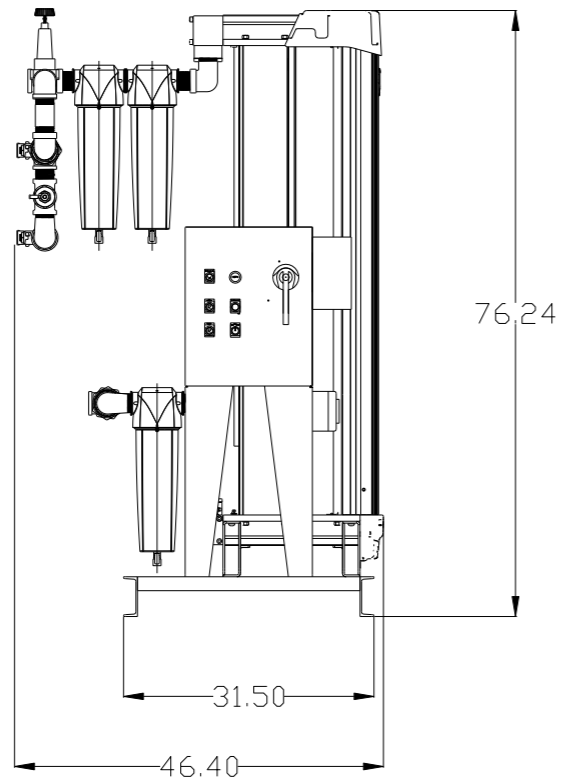

DEW POINT
MONITOR

CO MONITOR

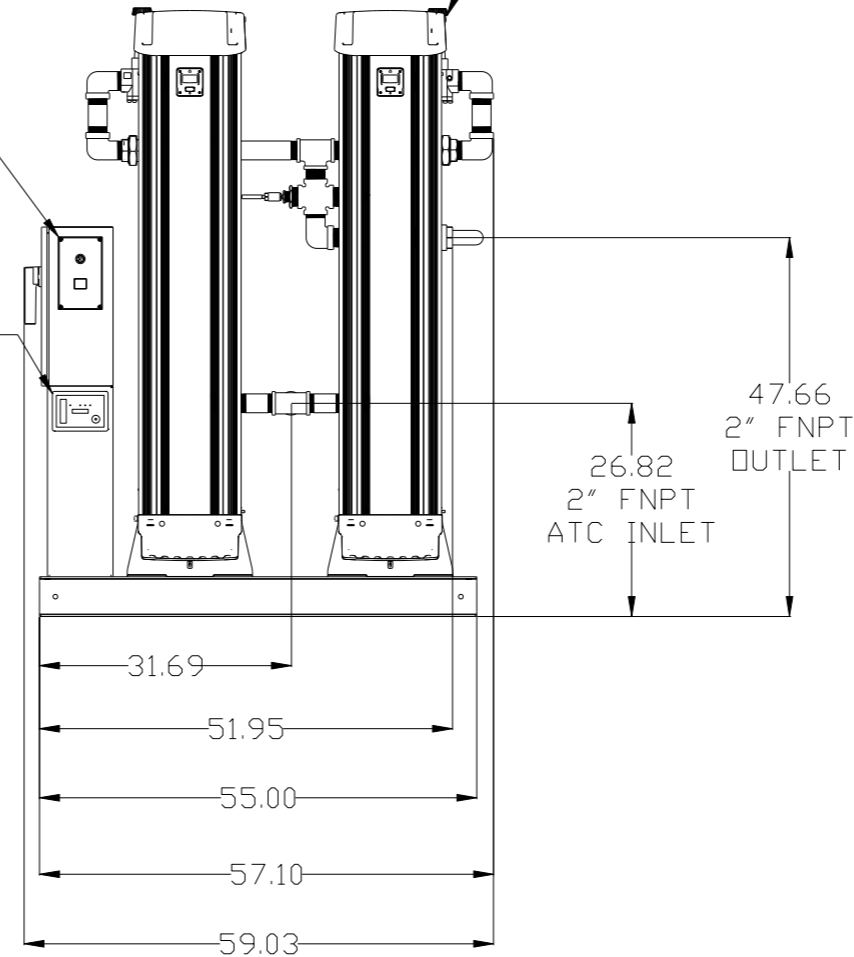

SYMBOL LEGEND		ADDITIONAL CONTROL REQ'D		Drawings to conform to the current revision of the following ANSI standards:	
⊖	MINUS DRAFT	⊕	PLUS DRAFT	⊕	BRINELL HARDNESS
TOLERANCES NOT SPECIFIED		AUTOCAD REL2008 LT		DO NOT SCALE DRAWING FOR DIMENSIONS	
.XX ±	.XXX ±	INCH		Sheet 3 of 5	
CONFIDENTIAL DISCLOSURE		This drawing is the property of POWEREX, INC. of the SCOTT FETZER COMPANY and subject to return on demand. Its contents are confidential and must not be copied or submitted to outside parties for use or examination.		SCALE 1:12	
DRAWN BY		CHECKED BY		APPROVED BY	
RK		AEK		JA CT	
8/6/13		8/7/13		8/7/12 8/7/12	
MATERIAL		N/A			
PART NAME		DRYER PACKAGE SKID			
55" X 31.5"		DWG NO		MDRE0757	
				SIZE D	

REV	ZONE	REVISION	DATE	ECN	NAME	CHKD
A-1	ALL	SUBMITTAL DRAWINGS	8/7/13	PKEC0052	RK	AEK
B-1	ALL	RELEASE FOR PRODUCTION	8/7/13	PKEC0052	RK	AEK
C-1	ALL	CHANGED TANK PSI FROM 200 TO 165	04/26/18	PKEC0229	DMS	GES

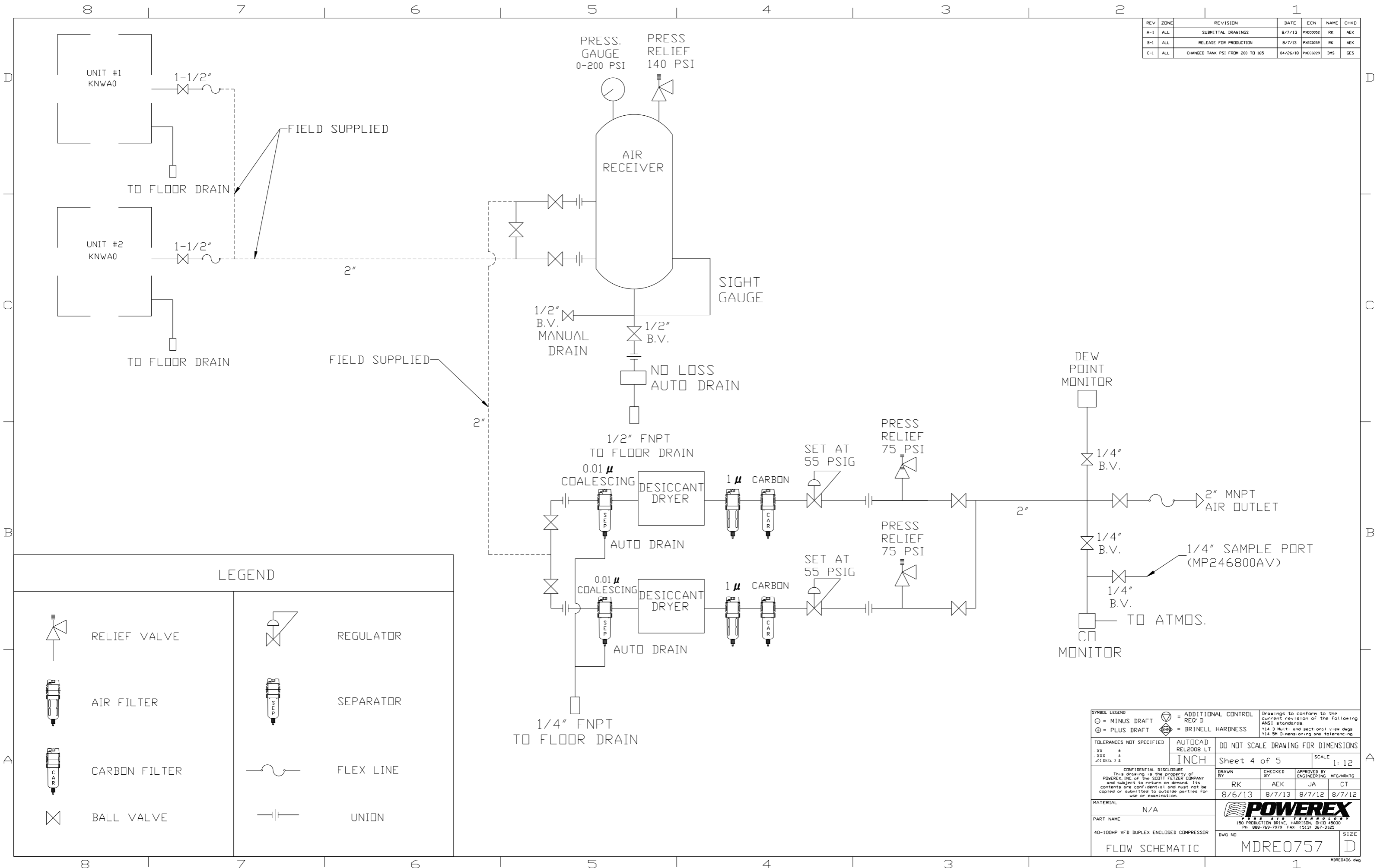

LEGEND

	RELIEF VALVE		REGULATOR
	AIR FILTER		SEPARATOR
	CARBON FILTER		FLEX LINE
	BALL VALVE		UNION

SYMBOL LEGEND ⊖ = MINUS DRAFT ⊕ = PLUS DRAFT HRC = BRINELL HARDNESS		ADDITIONAL CONTROL REQ'D = BRINELL HARDNESS	Drawings to conform to the current revision of the following ANSI standards: Y14.3 Multi and sectional view dwgs. Y14.5M Dimensioning and tolerancing
TOLERANCES NOT SPECIFIED .XX ± .XXX ± \angle(DEG.) ±		AUTOCAD REL2008 LT INCH	DO NOT SCALE DRAWING FOR DIMENSIONS Sheet 4 of 5 SCALE 1:12
CONFIDENTIAL DISCLOSURE This drawing is the property of POWEREX, INC. of the SCOTT FETZER COMPANY and subject to return on demand. Its contents are confidential and must not be copied or submitted to outside parties for use or examination.		DRAWN BY: RK CHECKED BY: AEK 8/6/13 8/7/13	APPROVED BY: JA, CT 8/7/12 8/7/12
MATERIAL: N/A		 150 PRODUCTION DRIVE, HARRISON, OHIO 45030 Ph: 888-769-7979 FAX: (513) 367-3125	
PART NAME: 40-100HP VFD DUPLEX ENCLOSED COMPRESSOR		DWG NO: MDRE0757	SIZE: D
FLOW SCHEMATIC		MRE0406.dwg	

REV	ZONE	REVISION	DATE	ECN	NAME	CHKD
A-1	ALL	SUBMITTAL DRAWINGS	8/7/13	PXEC0052	RK	AEK
B-1	ALL	RELEASE FOR PRODUCTION	8/7/13	PXEC0052	RK	AEK
C-1	ALL	CHANGED TANK PSI FROM 200 TO 165	04/26/18	PXEC0829	DMS	GES

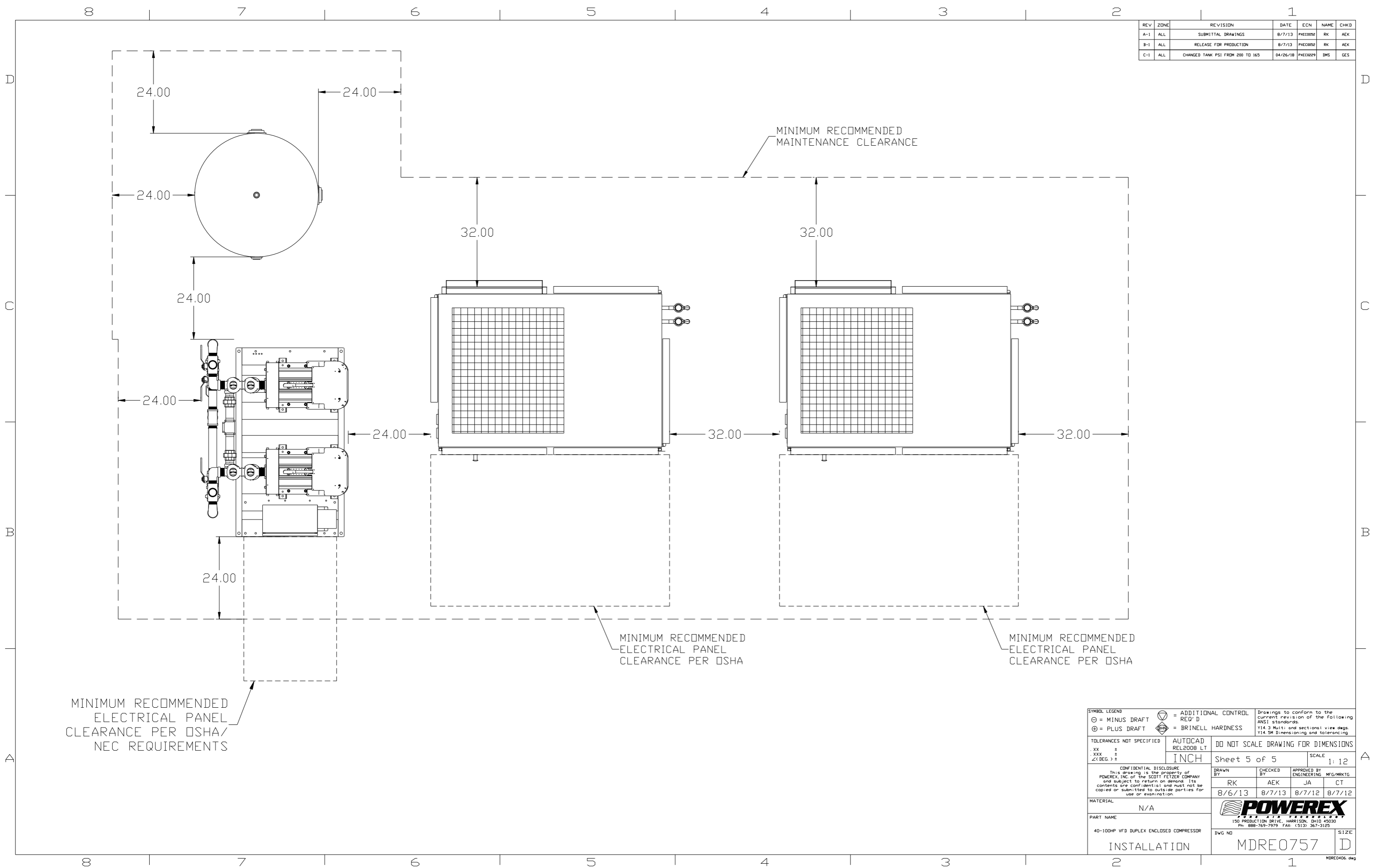

SYMBOL LEGEND ⊖ = MINUS DRAFT ⊕ = PLUS DRAFT .XX ± .XXX ± Z<DEG.> ±		⊕ = ADDITIONAL CONTROL RED'D ⊕ = BRINELL HARDNESS		Drawings to conform to the current revision of the following ANSI standards: Y14.3 Multiview and sectional view dsgs. Y14.5M Dimensioning and tolerancing	
TOLERANCES NOT SPECIFIED AUTOCAD REL2008 LT INCH		DO NOT SCALE DRAWING FOR DIMENSIONS Sheet 5 of 5 SCALE 1:12		CONFIDENTIAL DISCLOSURE This drawing is the property of POWEREX, INC. of the SCOTT FITZGER COMPANY and subject to return on demand. Its contents are confidential and must not be copied or submitted to outside parties for use or examination.	
DRAWN BY RK		CHECKED BY AEK		APPROVED BY ENGINEERING MFG/MKTG JA CT	
DATE 8/6/13		DATE 8/7/13		DATE 8/7/12 8/7/12	
MATERIAL N/A		PART NAME 40-100HP VFD DUPLEX ENCLOSED COMPRESSOR		DWG NO MDRE0757	
INSTALLATION		SIZE D		MDRE0406 096	