

REVISION NOTES		
DESCRIPTION	ECN	PR/NOR
PRODUCTION RELEASE	PXEC0099	N/A

# MCET1505

## MED CLAW ENCLOSED TRIPLEX 15 HP 200 GAL

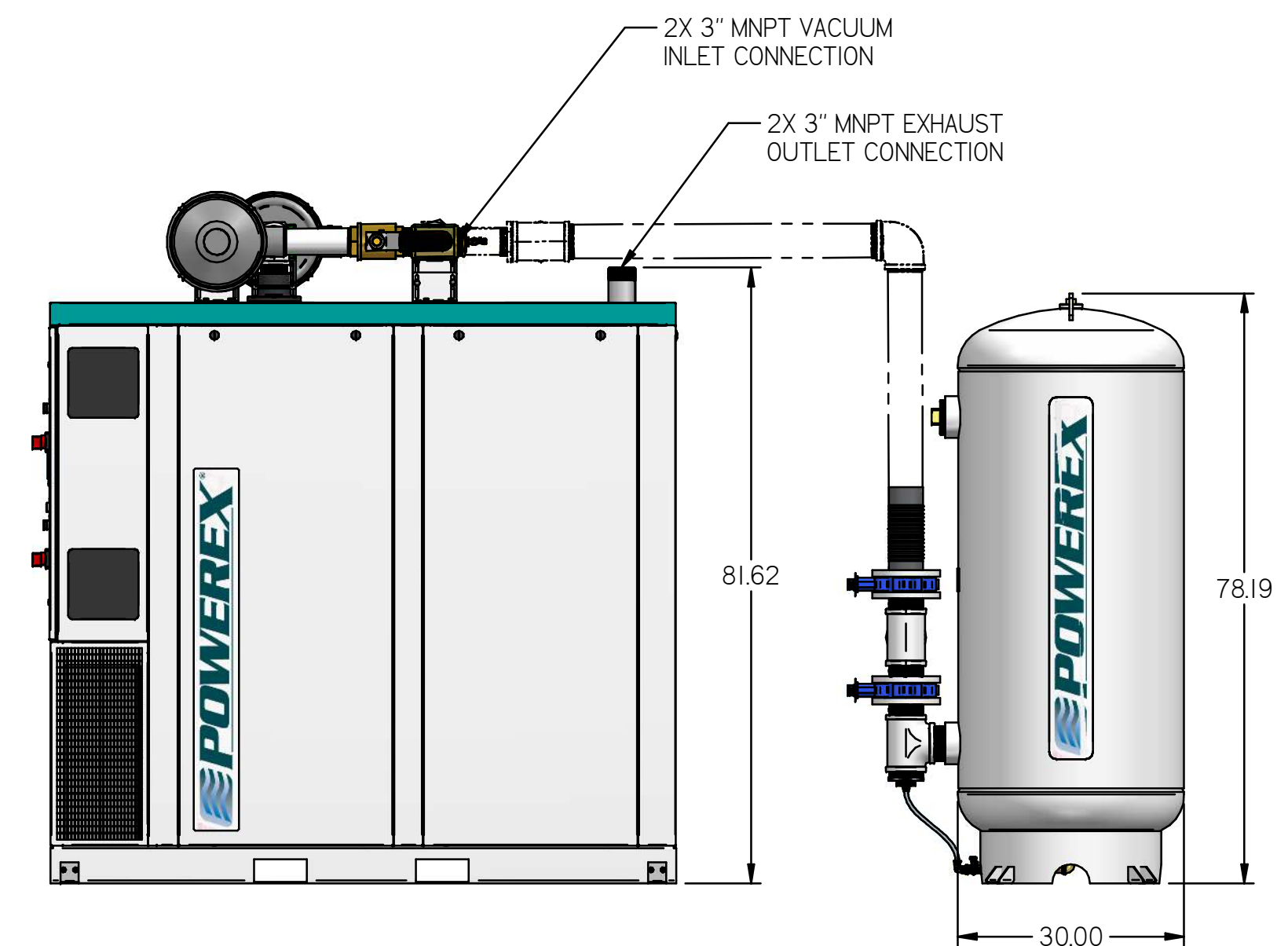
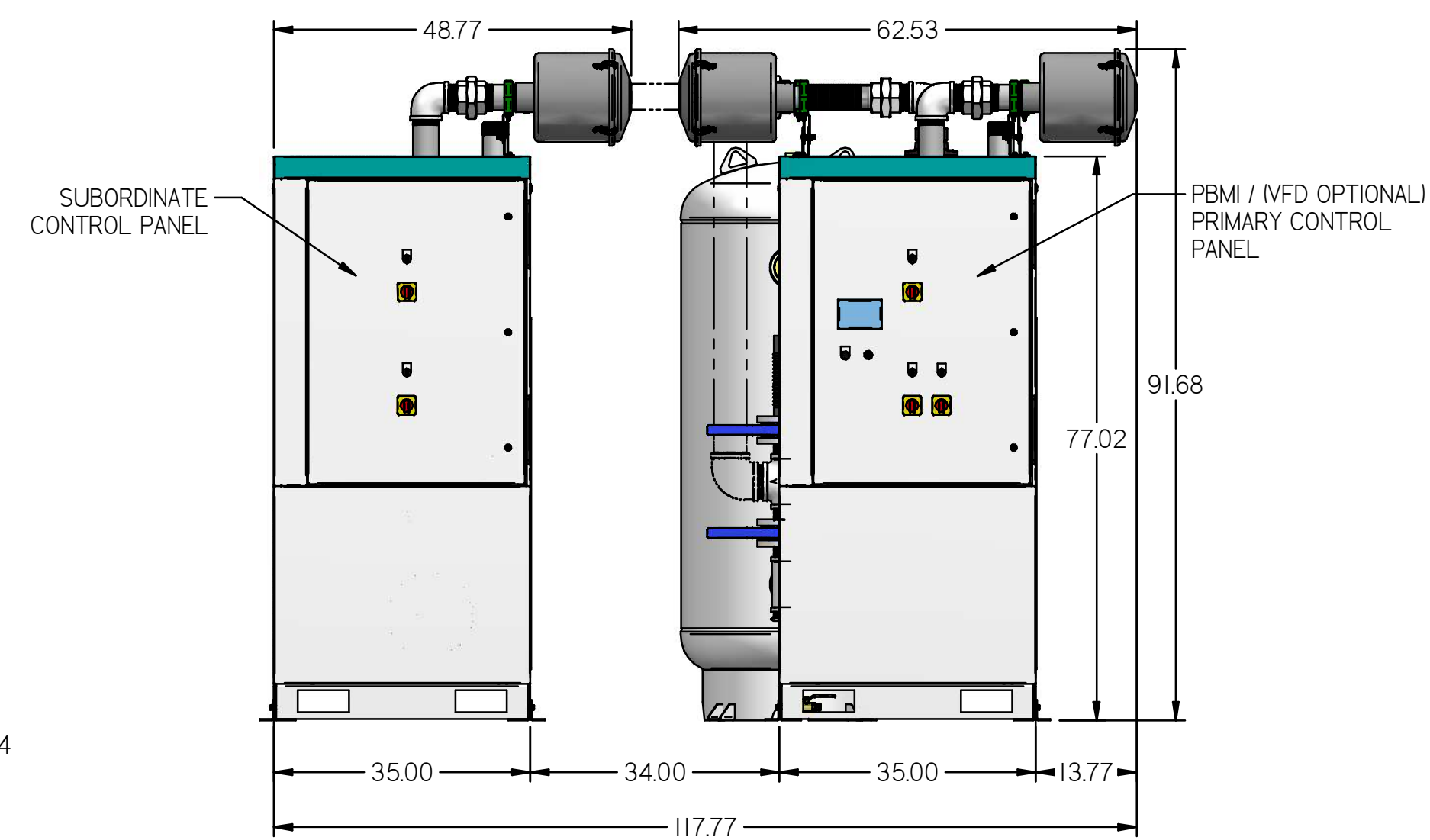
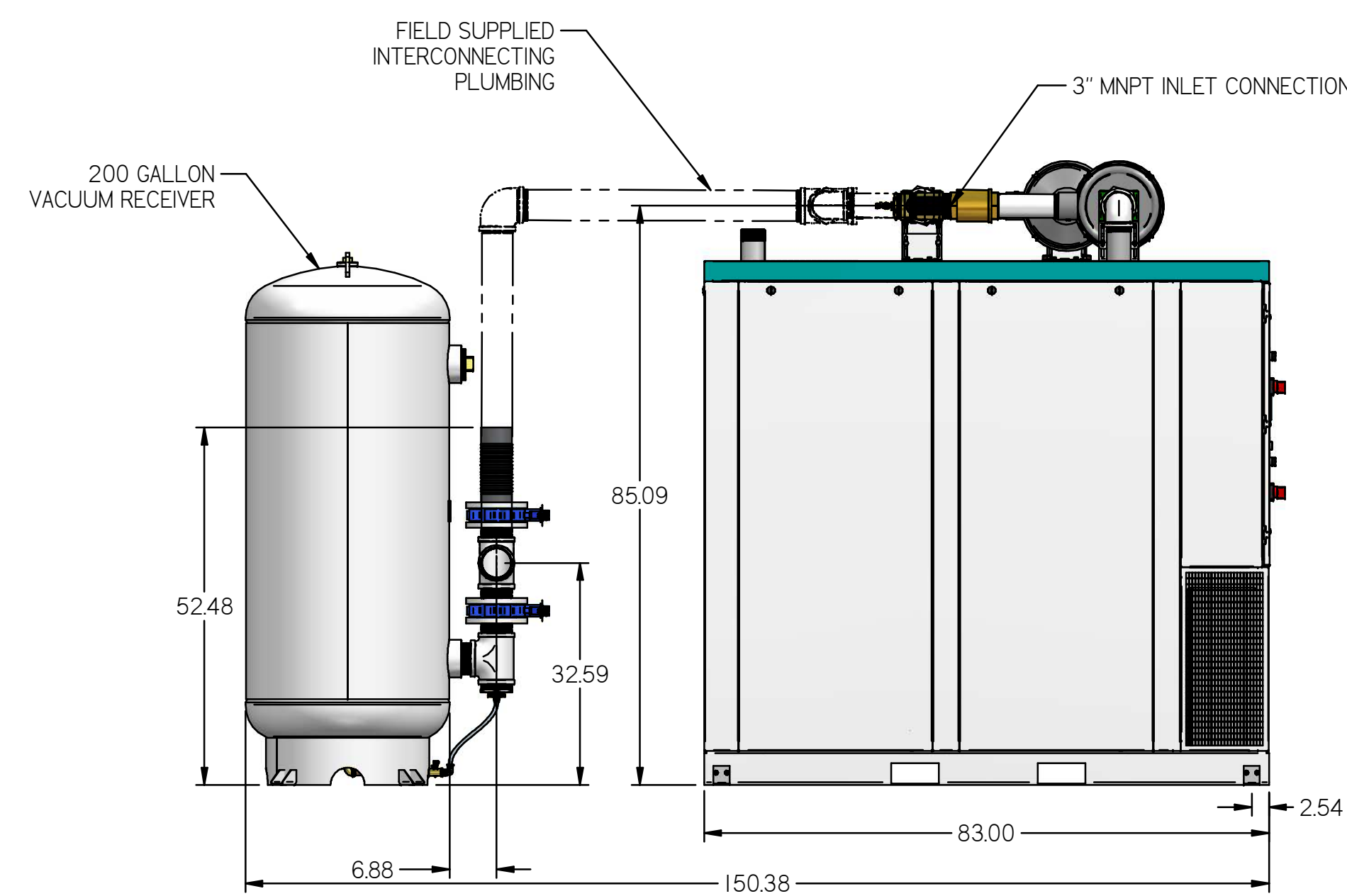
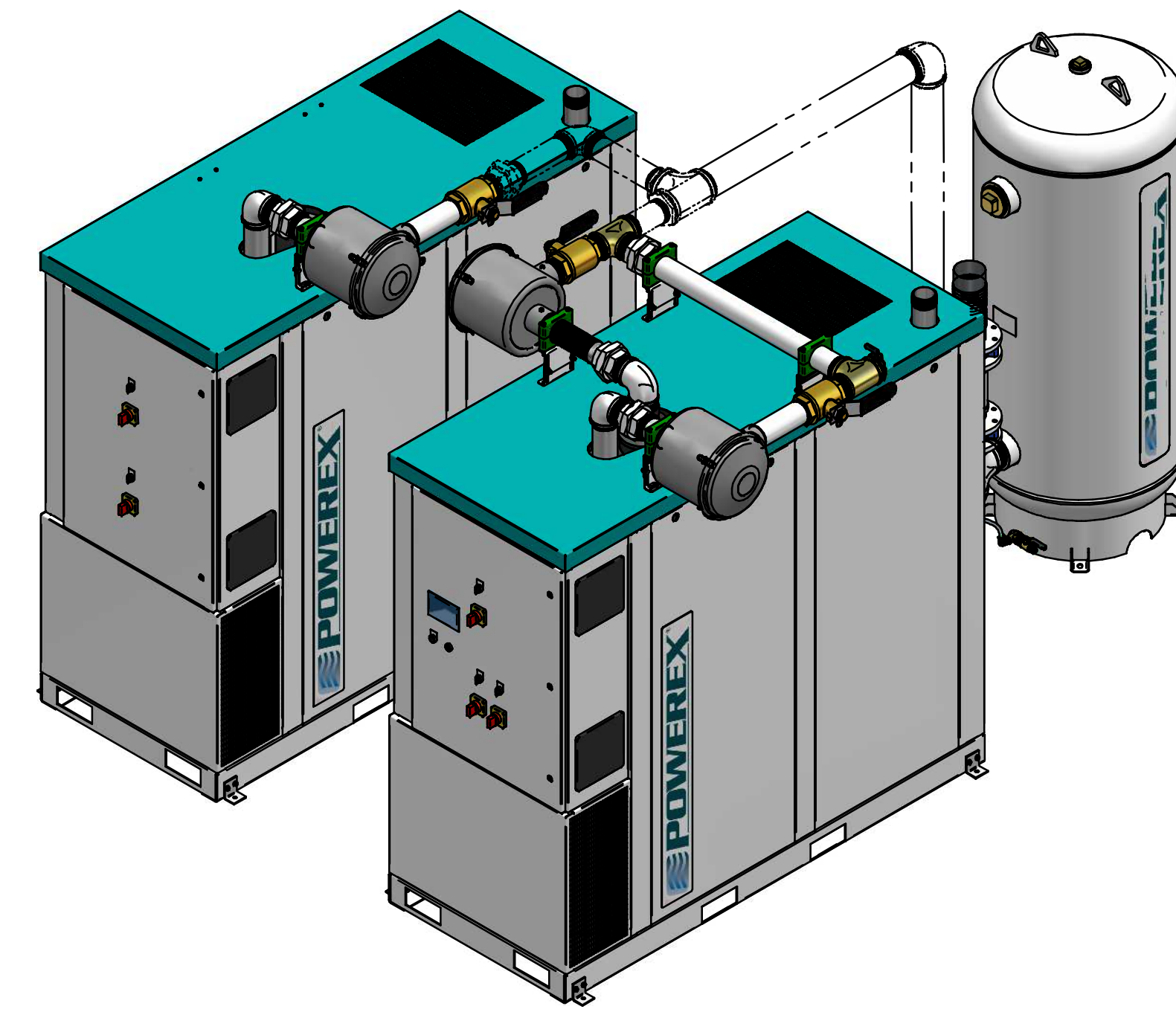
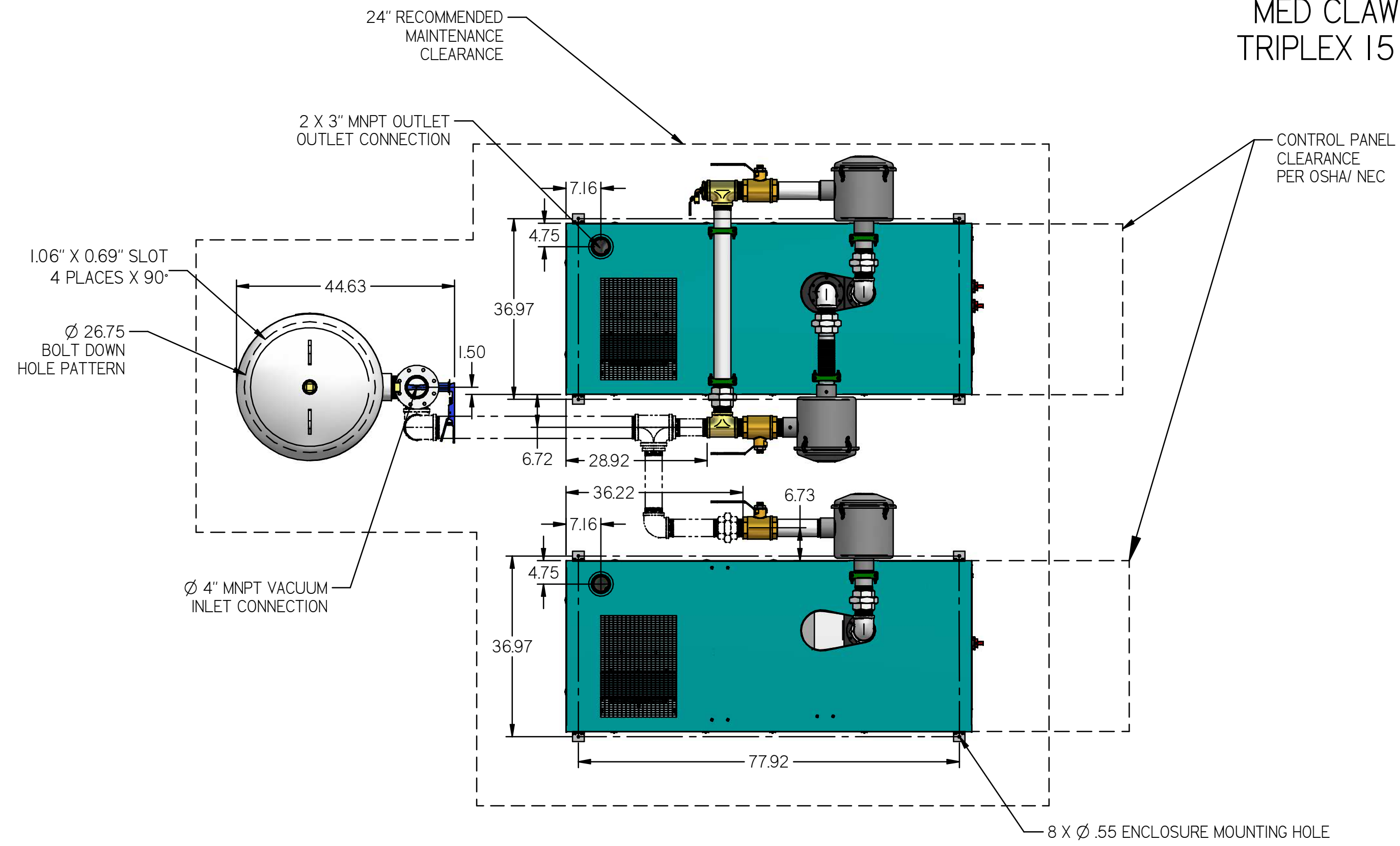

- NOTES:
- 1) APPROX SYSTEM WEIGHT: 6839 LB
  - 2) FINAL SYSTEM DIMENSIONS DEPENDENT UPON INSTALLATION CONFIGURATION. MAINTENANCE CLEARANCE MUST BE MAINTAINED IN INSTALLATION CONFIGURATION.
  - 3) SHEET 1: UNIT BUILD
  - 4) SHEET 2: FLOW SCHEMATIC

SYMBOL LEGEND		DRAWINGS TO CONFORM TO CURRENT REVISION OF THE FOLLOWING ANSI STANDARDS:	
		Y14.3 MULTI AND SECTIONAL VIEW DIMS	
		Y14.5 DIMENSIONING AND TOLERANCING	
TOLERANCES NOT SPECIFIED:	SOLID EDGE DRAWING	DO NOT SCALE DRAWING FOR DIMENSIONS	
0.XXX ± 0.010	INCH	SHEET 1 OF 2	SCALE 1:20
0.XXX ± 0.050			
± 0.5			
CONFIDENTIAL DISCLOSURE This drawing is the property of POWEREX or the SCOTT FETTER COMPANY and is subject to return on demand. Its contents are confidential and must not be copied or submitted to outside parties for use or examination.		AUTHOR	APPROVALS ON FILE IN PLM
DRAWER: 718763		gseaver	2/7/2019
MATERIAL: N/A			
DESCRIPTION: MED CLAW ENCLOSED TRIPLEX 15 HP 200 GAL		DRAWING NUMBER: MCET1505	REVISION: B
		SIZE: B	SIZE: D

# MCET1505

## MED CLAW ENCLOSED TRIPLEX 15 HP 200 GAL

REVISION NOTES		
DESCRIPTION	ECN	PR/NOR
PRODUCTION RELEASE	PXEC0099	N/A

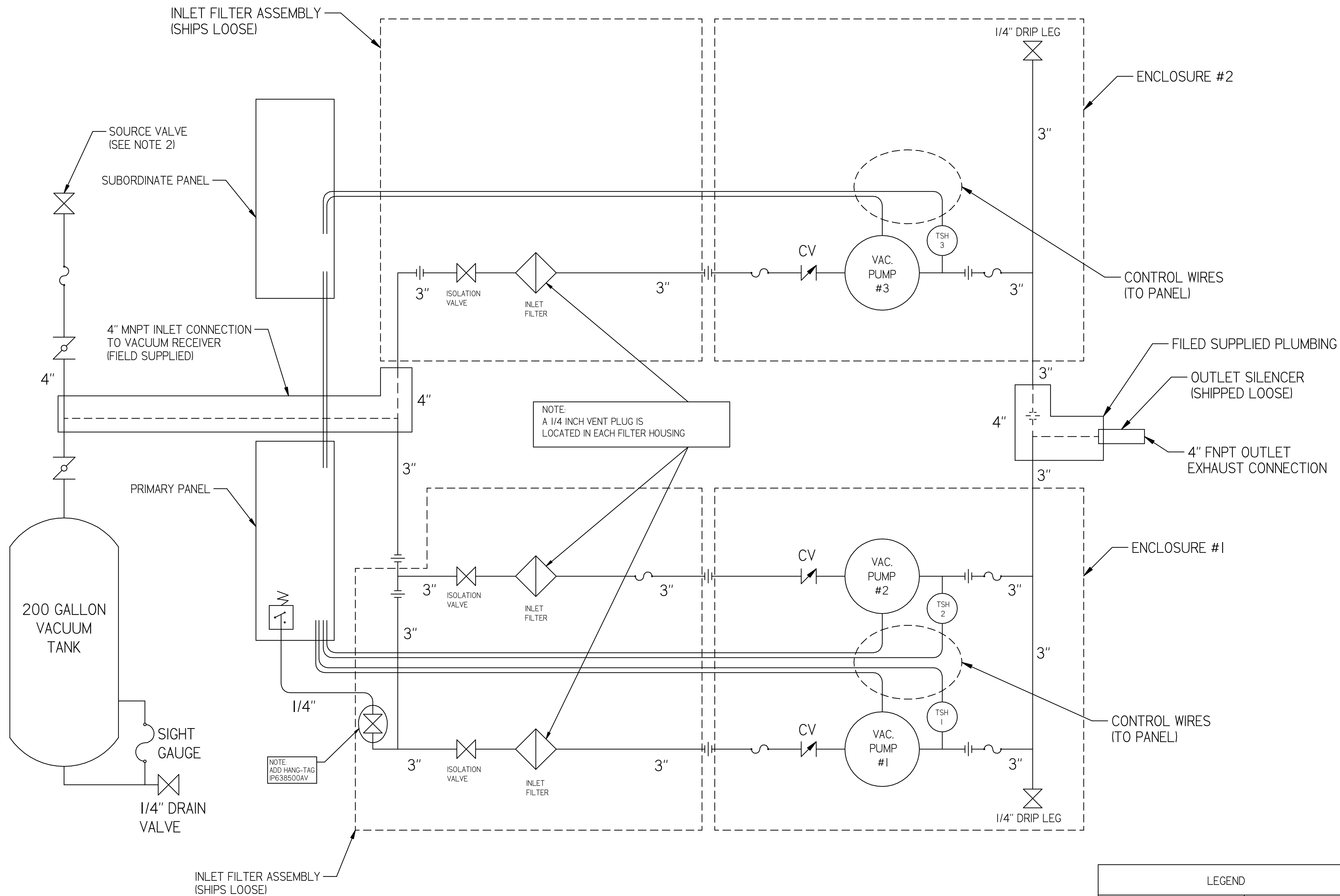

NOTES:  
1) TSH - TEMPERATURE SWITCH HIGH.  
2) PER NFPA: THE SYSTEM WILL REQUIRE  
A SOURCE VALVE (SUPPLIED BY OTHERS).

LEGEND	
TSH	TEMP. SWITCH
AIR FILTER	
BALL VALVE	
BUTTERFLY VALVE	
VACUUM TRANSDUCER	
CHECK VALVE	
FLEX LINE	
UNION	

SYMBOL LEGEND		DRAWINGS TO CONFORM TO CURRENT REVISION OF THE FOLLOWING ANSI STANDARDS: Y14.3 MULTI-VIEW AND SECTIONAL VIEW DWGS Y14.5 DIMENSIONING AND TOLERANCING	
TOLERANCES NOT SPECIFIED	SOLID EDGE DRAWING	DO NOT SCALE DRAWING FOR DIMENSIONS	
0.00X ± 0.010	INCH	SHEET 2 OF 2	SCALE 1:1
0.000X ± 0.0050		APPROVALS ON FILE IN PLM	
< ± 0.5		gseaver 2/7/2019	
<small>CONFIDENTIAL DISCLOSURE</small> This drawing is the property of POWEREX of the SCOTT FETTER COMPANY and is subject to return on demand. Its contents are confidential and must not be copied or submitted to outside parties for use or examination.			
ITEM # 718763 MATERIAL N/A DESCRIPTION MED CLAW ENCLOSED TRIPLEX 15 HP 200 GAL	DRAWING NUMBER MCET1505	REVISION B	SIZE D

