

VPT2005PI-EX4

20HP VACUUM 200GAL
TRIPLEX EX4

REVISION NOTES		
DESCRIPTION	ECN	PR/NOR
3D RELEASE	PXEC0293	N/A

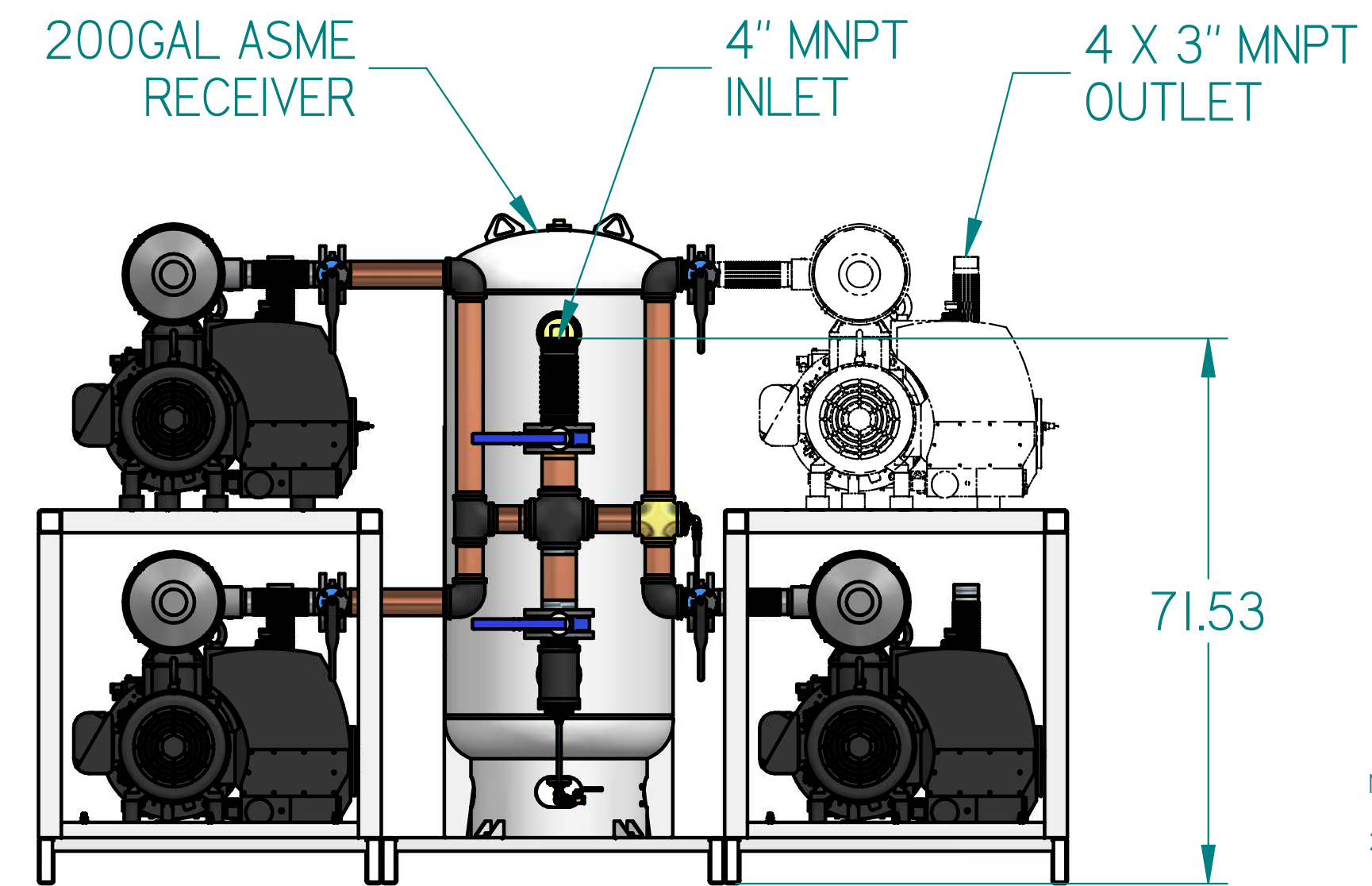
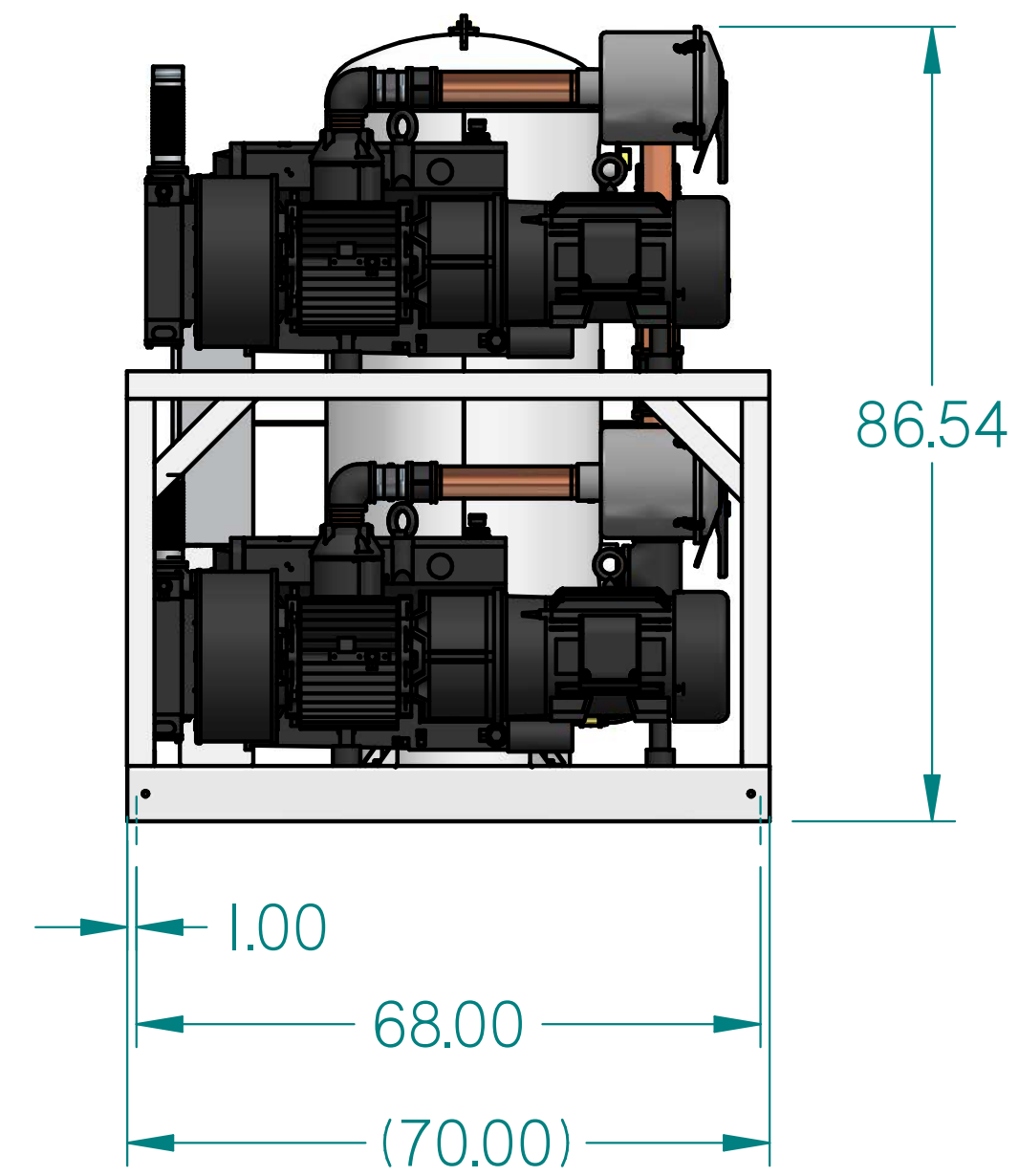
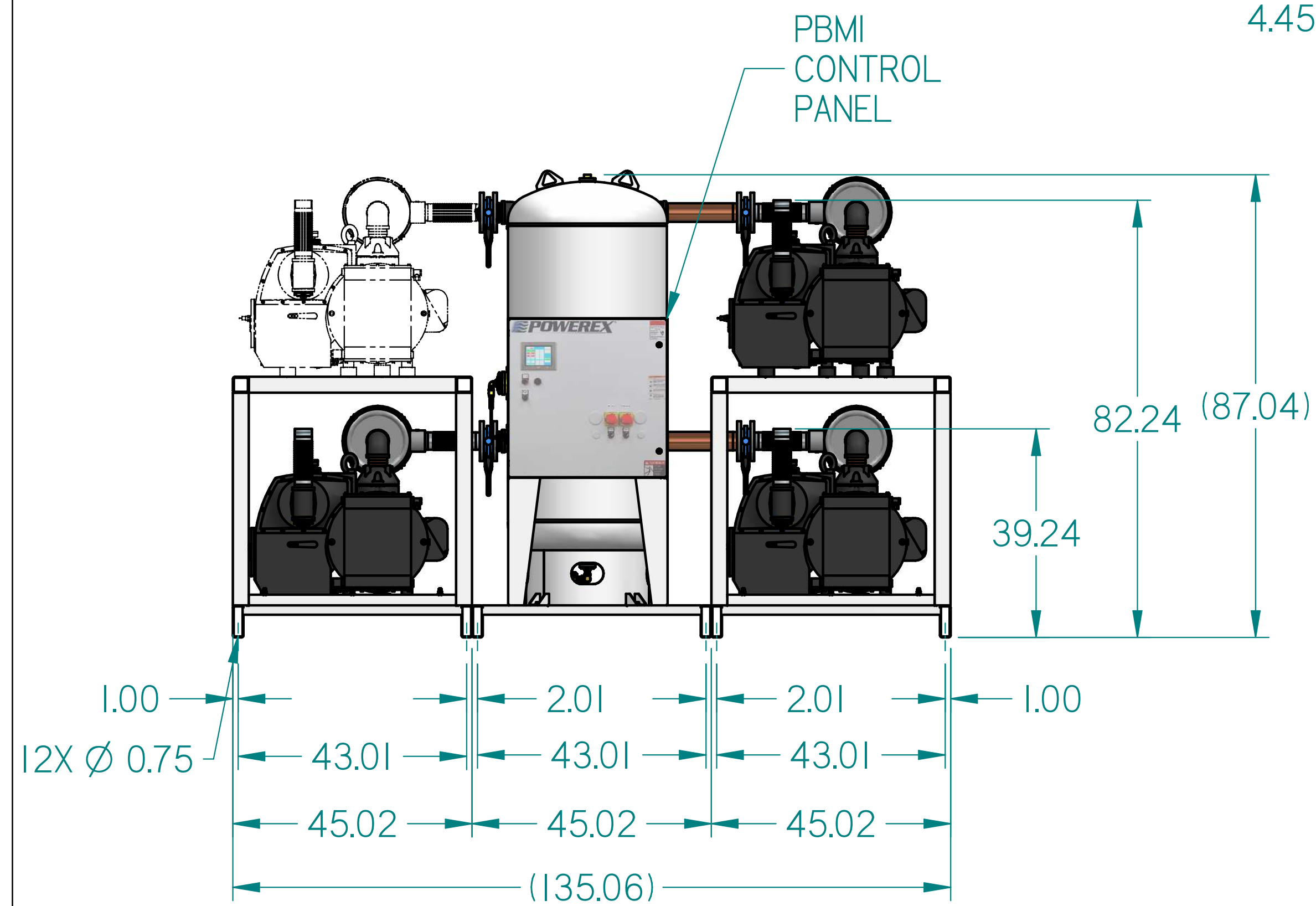
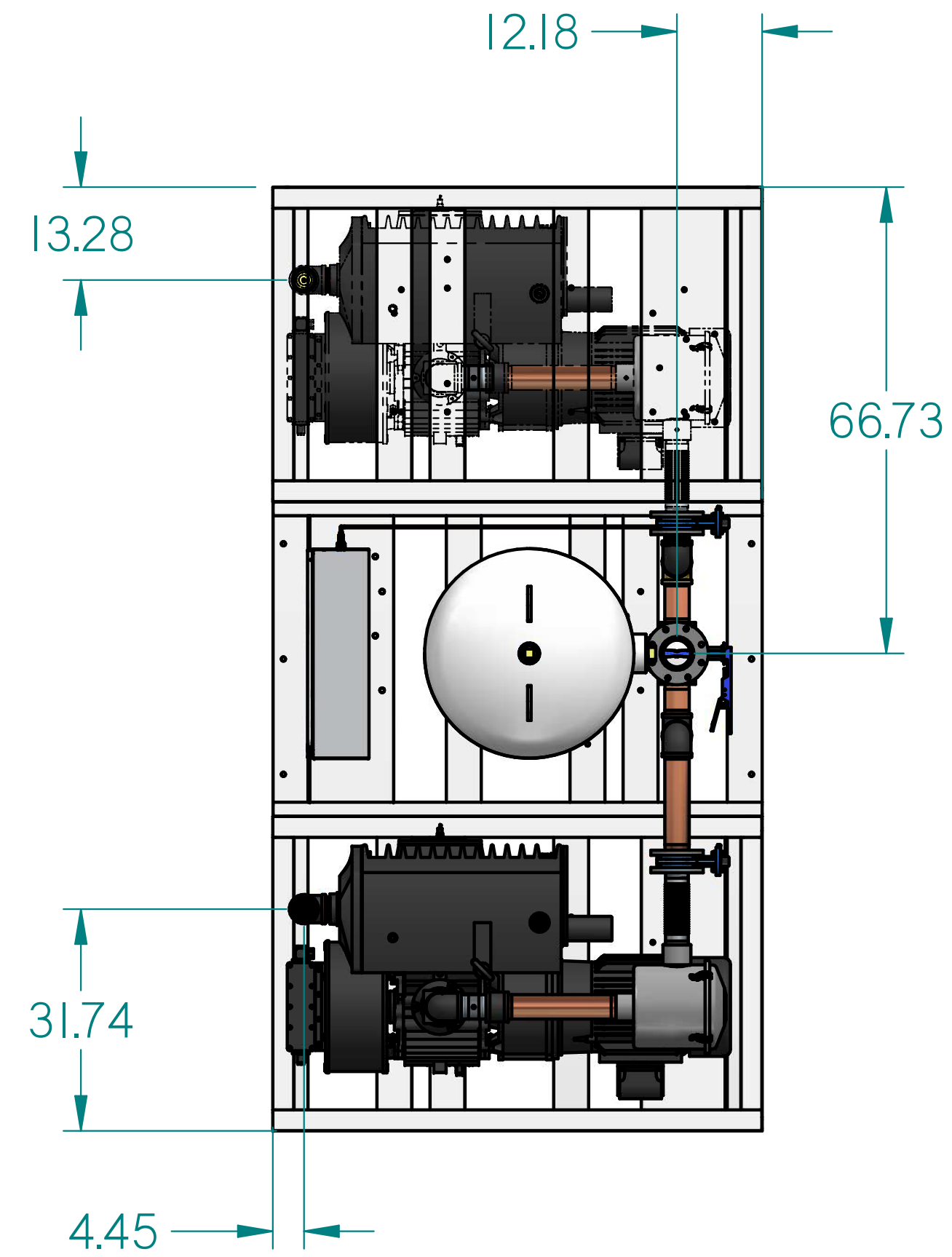

- NOTES:
1. APPROXIMATE WEIGHT: 6076 lbm
 2. A MINIMUM OF 24" CLEARANCE IS RECOMMENDED AROUND THE ENTIRE UNIT. CLEARANCE FOR CONTROL PANEL SHALL BE IN ACCORDANCE WITH OSHA/NEC REQUIREMENTS.
 3. SYSTEM DESIGNED IN COMPLIANCE WITH U.S. NFPA '99, LATEST EDITION.

SYMBOL LEGEND		DRAWINGS TO CONFORM TO CURRENT REVISION OF THE FOLLOWING ANSI STANDARDS:	
		#14.3 MULTI AND SECTIONAL VIEW DWGS	
		#14.5 DIMENSIONING AND TOLERANCING	
TOLERANCES NOT SPECIFIED:	SOLID EDGE DRAWING	DO NOT SCALE DRAWING FOR DIMENSIONS	
0.004 ± .005	INCH	SHEET 1 OF 2	SCALE 1:8
0.0005 ± .001	INCH	APPROVALS ON FILE IN PLM	
CONFIDENTIAL DISCLOSURE: This drawing is the property of POWEREX of the SCOTT FETTER COMPANY and is subject to return on demand. Its contents are confidential and must not be copied or submitted to outside parties for use or examination.		AUTHOR	ORIGINATION DATE
		TATA	03-04-2019
ITEM ID			
MATERIAL	ISO PRODUCTION DRIVE, HARRISON OH 45030 (888) 768-7079		
DESCRIPTION	DRAWING NUMBER	REVISION	SIZE
20HP VACUUM 200GAL TRIPLEX EX4	VPT2005PI-EX4		D

VPT2005PI-EX4

20HP VACUUM 200GAL
TRIPLEX EX4

REVISION NOTES		
DESCRIPTION	ECN	PR/NOR
3D RELEASE	PXEC0293	N/A

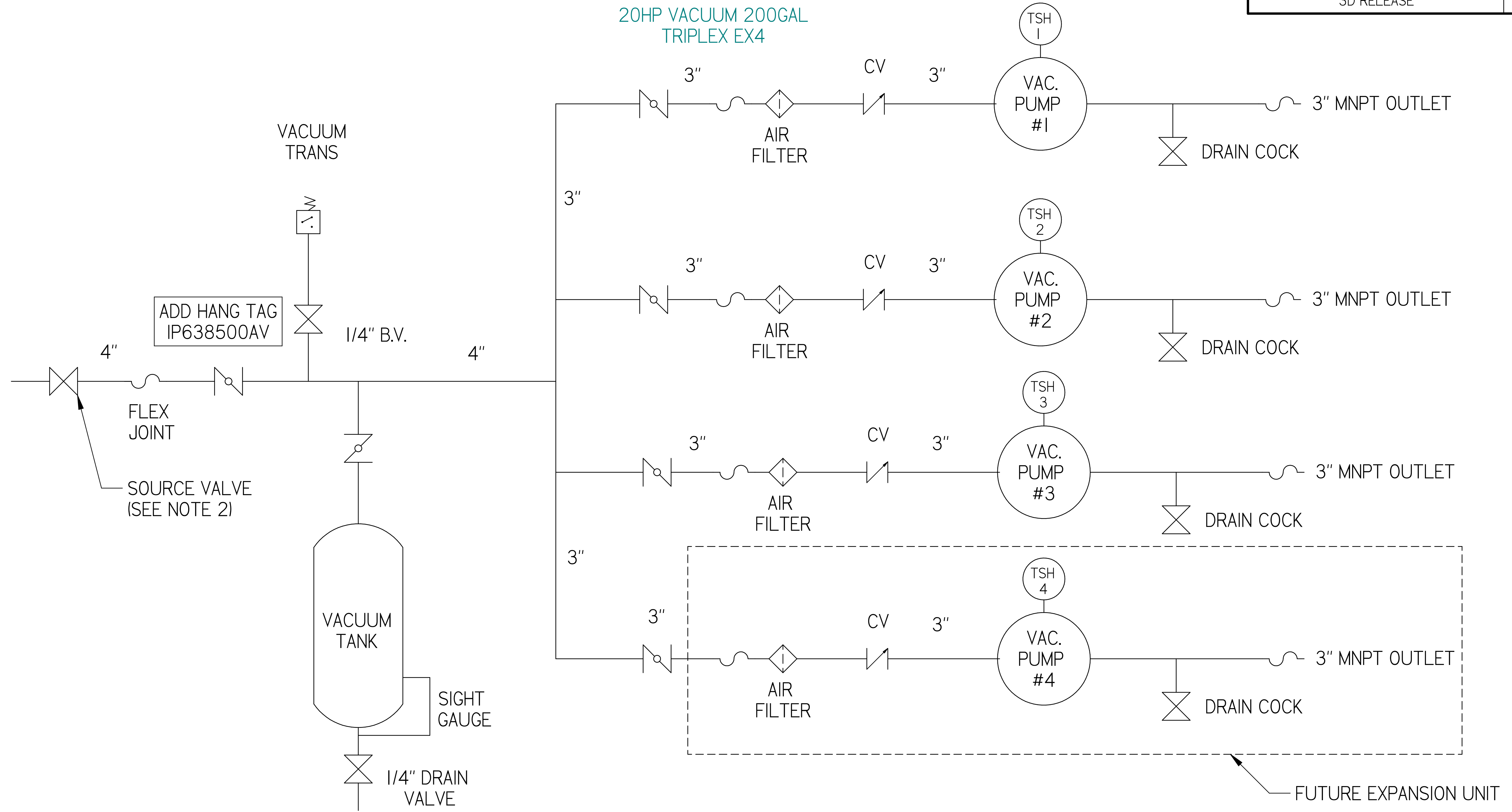

LEGEND

	TEMP. SWITCH		VACUUM SWITCH
	AIR FILTER		CHECK VALVE
	BALL VALVE		FLEX LINE
	BUTTERFLY VALVE		UNION

NOTE:
A 1/4 INCH VENT PLUG IS
LOCATED IN THE FILTER HOUSING

NOTES:
1) TSH - TEMPERATURE SWITCH HIGH
2) PER NFPA THE SYSTEM WILL REQUIRE A SOURCE VALVE (SUPPLIED BY OTHERS)

SYMBOL LEGEND		DRAWINGS TO CONFORM TO CURRENT REVISION OF THE FOLLOWING ANSI STANDARDS: #14.3 MULTI AND SECTIONAL VIEW DWGS #14.5 DIMENSIONING AND TOLERANCING	
TOLERANCES NOT SPECIFIED:	SOLID EDGE DRAWING	DO NOT SCALE DRAWING FOR DIMENSIONS	
0.001 ± .001	INCH	SHEET 2 OF 2	SCALE 1:1
CONFIDENTIAL DISCLOSURE This drawing is the property of POWEREX of the SCOTT FETTER COMPANY and is subject to return on demand. Its contents are confidential and must not be copied or submitted to outside parties for use or examination.		AUTHOR	APPROVALS ON FILE IN PLM
MATERIAL		TATA	03-04-2019
ITEM ID			
DESCRIPTION 20HP VACUUM 200GAL TRIPLEX EX4		DRAWING NUMBER VPT2005PI-EX4	REVISION SIZE D