

Scroll Tankmount Enclosed Compressor Systems

Please read and save these instructions. Read carefully before attempting to assemble, install, operate or maintain the product described. Protect yourself and others by observing all safety information. Failure to comply with instructions could result in personal injury and/or property damage! Retain instructions for future reference.

Description

Powerex 7.5 and 10 horsepower Scroll Tank-mounted Enclosed Simplex and Duplex compressor units are designed to provide clean dry compressed air for applications in laboratory and other industries where a quiet, compact source of compressed air is desired.

The sound reduction enclosure allows the almost vibration free compressor to be installed in locations where other compressors would be objectionable. The units are available configured with automatic controls, air receiver tanks and refrigerated or desiccant dryers.

Simplex Systems have a touch screen control panel with integrated PLC that responds to signals from the pressure transducer to control the electric motor that drives the pump. The screen displays system status and provides warnings for high discharge air temperature and motor overload. Operating hours and maintenance requirements are displayed as well.

Duplex Systems also have a touch screen control panel and integrated PLC that will automatically alternate usage of the two available compressor sets and will run both upon demand. One touch screen operates both of the installed compressor sets.

Models are available with refrigerated and desiccant dryers. Simplex models have the dryers mounted and plumbed. Desiccant dryers on simplex units are wired to the main power circuit. Duplex models require separate mounting, plumbing and wiring.

Safety Guidelines

This manual contains information that is very important to know and understand. This information is provided for SAFETY and to PREVENT EQUIPMENT PROBLEMS. To help recognize this information, observe the following symbols.

Danger indicates an imminently hazardous situation which, if not avoided, WILL result in death or serious injury.

Warning indicates a potentially hazardous situation which, if not avoided, COULD result in death or serious injury.

Caution indicates a potentially hazardous situation which, if not avoided, MAY result in minor or moderate injury.

Notice indicates important information, that if not followed, may cause damage to equipment.

NOTE: Note indicates information that requires special attention.

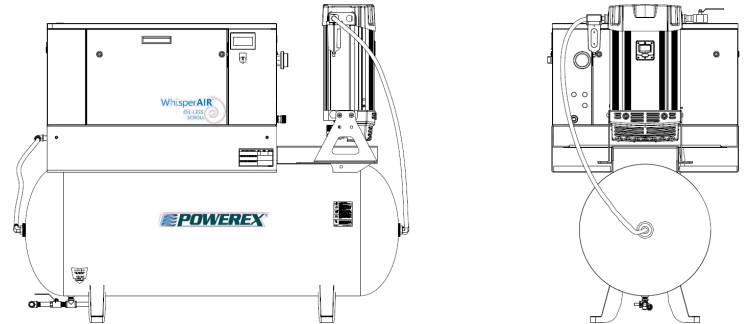

STES Scroll Tankmount Enclosure – Simplex with Dryer

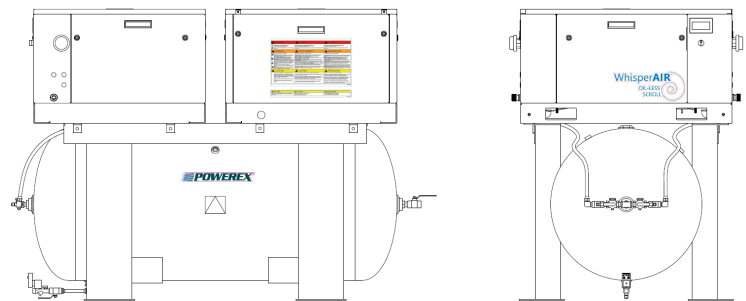

STED Scroll Tankmount Enclosure – Duplex

SPECIFICATIONS	
Product	STE Series Tankmount Enclosed Scroll Air Compressor
Default Operating Pressure (psig)	95-115 (Simplex) 90-110; 95-115 (Duplex)
Usable in Ambient Temperature Range	34°F - 104°F (Maintenance intervals decreased if ambient is over 85°F)
Input Electrical Power	3 phase, 208-230/460 60 Hz
Control – UL508A	Simplex – IEC Type overload relay Duplex – Motor protector circuit breaker
Pump Drive	2 - 3V Belts
CA Ordinance 462(L)(2)	Unit meets requirements
Lubrication	Grease filled bearings Use Powerex Grease as specified

Compressor Pumps or Air Ends

The Powerex Scroll Compressor offers a dynamically balanced air end which insures vibration-free operation. The rotary design permits a continuous 100% duty cycle. No oil separation, oil filtration, or inlet valves are required on the Powerex Scroll air compressor.

The Powerex oilless rotary scroll air compressor is based on the theory of scroll compression. A scroll is a free standing, intricate spiral bounded on one side by a solid, flat plane or base. A scroll set, the basic compression element of a scroll compressor, is made up of two identical spirals which form right and left hand parts. One of these scroll components is indexed or phased 180° with respect to the other so the scrolls can mesh.

Crescent-shaped gas pockets are formed and bounded by the spirals and the base plate of both scrolls. As the orbiting scroll is orbited around the fixed scroll, the pockets formed by the meshed scrolls follow the spiral toward the center and diminish in size. The orbiting scroll is prevented from rotating during this process so the 180° phase relationship of the scrolls is maintained. The compressor's inlet is at the outer boundary of the scrolls. The compressed gas is discharged through the outlet at the center of the fixed scroll so no valves are needed.

Tip Seals & Bearing Grease

On 7.5 and 10 HP scroll pumps, the normal maintenance interval for tip seals and bearing grease is 8,000 hours.

System Components

Sound Reducing Enclosure

The Powerex precision enclosure is constructed from steel panels and formed steel braces. The panels are lined with sound absorbing foam and have ventilation ports and sound baffles to allow maximum cooling while eliminating noise and vibration. Do not modify or block any ventilation openings. Do not operate the units without panels in place, as the panels prevent accidental contact with live electric parts, hazardous moving parts, and hot parts of the system.

⚠ DANGER

Risk of Electrocutation. Risk of Death or Injury. Do not operate without all enclosure panels in place.

Motors

The Powerex STES and STED units utilize TEFC, 2 pole, 3 phase, induction motors. The motors are fully installed and wired by Powerex. The motors meet current US requirements for energy efficiency. If motor replacement becomes necessary use Powerex supplied motors.

Mechanical Drive

The pump pulley is an integrated part of the pump balancing system. Do not modify or remove it. The pump is designed to be driven by two 3-V cross section belts. A convenient belt tensioning system is provided by Powerex. Follow the instructions under maintenance to assure maximum belt life and reliability. The motor side drive pulley

with a taper bushing mount is sized by Powerex for optimum loading of the motor under design pressure conditions. Do not change the drive pulley size.

Compressor Intake Filter

The compressor has a compressed air intake port at the upper right corner of the enclosure. The intake port is connected to an internal air filter canister with a replaceable pleated paper element. Do not modify or remove any part of the intake system.

Compressor Outlet Piping & After Cooler System

The after cooler is constructed of non-rusting materials and is designed to remove the heat of compression from the product air. Do not modify the after cooler or obstruct air flow over the cooling fins. The after cooler system utilizes air flow from the pump for bulk cooling of the compressed air. Additional cooling air flow is provided by a fan utilizing outside air for the best possible outlet temperature. The after cooler is positioned so that condensed liquid is constantly swept away from the pump.

Check Valve

Each scroll compressor pump is equipped with a check valve to prevent backflow of compressed air from the receiver tank when the motor is shut off. The check valve is mounted after the after cooler for maximum reliability and durability. The pump will experience a few reverse turns when power is shut off as trapped compressed air is released. If reverse rotation continues for more than a few seconds, it is likely the check valve is malfunctioning and needs to be replaced.

Air Receiver Tank

The air receiver tank is constructed and labeled according to the ASME Boiler and Pressure Vessel Code.

The design pressure of the receiver is 200 psig, well above the operating range of the compressor system for maximum safety. An ASME safety relief valve with a relieving capacity higher than the pump output is installed.

Automatic Tank Drain

⚠ DANGER

Risk of death or injury from tank rupture. Never modify or remove the ASME Safety relief valve.

NOTICE

Even if the air receiver tank has a corrosion resistant lining; there are places at the threaded ports where bare steel is exposed to wet air. Rust at these locations is normal and does not pose any risk as the material thickness is many times the required amount for safe operation.

A timer controlled solenoid valve automatic drain is included. When the timer energizes the solenoid it allows accumulated condensate to be pushed out of the receiver by the air pressure. The test button can be used to verify operation at any time.

The timer controls are set at the factory for conservative duration and intervals. If condensate water accumulates in the tank and the automatic drain is confirmed to be working, increase the duration or frequency of open time or both.

The automatic tank drain is equipped with a screen to help prevent debris from interfering with the function of the valve. There is a build in quarter turn valve that can be closed so the screen can be removed for cleaning. A separate manually operated drain valve is installed in the tank drain as well.

Connect appropriate piping or tubing so that the expelled liquid is collected and disposed of in accordance with applicable regulations.

Receiver Sight Gauge

The air receiver (applicable to some models) has a sight gauge constructed from translucent polymer tubing that allows a visual check to verify that no liquid has accumulated in the tank.

Dryers & Filters

Simplex systems have the dryers mounted and plumbed. Operating power for refrigerated dryers or separately mounted dryers must be supplied separately.

Duplex systems require piping and power feed to be completed on site at the time of installation.

Refrigerated Dryer

If the system is ordered with a refrigerated dryer it has its own On/Off switch and has a condensate removal trap that will expel liquid. Connect appropriate piping or tubing so that the expelled liquid is collected and disposed of in accordance with applicable regulations.

Desiccant Dryer

The desiccant dryer is designed to provide a dew point of -40F as long as the incoming compressed air is 100F or less. If the compressor system is installed in an environment where the ambient temperature exceeds 90F, the dewpoint will be higher. The standard dryer has a fixed purge cycle. (Operation with purge saving controls requires installation and wiring of a separate dew point monitor with appropriate signaling capability.) If a desiccant dryer is used, it will have pre-filters and after filters. Do not operate the dryer without these filters in place and functioning properly as damage to the valves or desiccant can result. The pre-filters will expel condensate and appropriate piping or tubing should be installed to allow the liquid to be collected and disposed of as necessary to meet applicable regulations.

The outlet port of the dryer or after filter is provided with NPT threads to connect to your facility or application.

Anti-vibration Mounting Pads

The compressor set is internally mounted on vibration isolation pads. If desired, cork rubber composite pads can be used under the tank feet when securing to the floor. These are available separately from Powerex.

Electrical Controls

The STES and STED units have a touch screen control panel and a manual Hand/Off/Auto selector switch. The touch screen control has an integrated PLC that uses the signal from the pressure transducer to energize or de-energize the motor circuit in response to the need for

pressure. On duplex units, there is a single PLC that will automatically alternate the compressors to equalize wear and start the second compressor if the compressed air demand exceeds the capability of one compressor. The operating pressure range is adjustable within a preprogrammed range. If the compressor outlet temperature exceeds the setting of the temperature switch, the control will display a high temperature warning and shut off the compressor. The compressor will not restart until the alarm is cleared. The control also will display an overload warning if the motor current exceeds the preset value on the motor protector or overload relay. The overload condition must be reset before the motor can restart. The operating pressure and the accumulated run hours are displayed on the control screen. The selector switch allows operation in Hand mode, which will override the pressure control function of the PLC. If pressure exceeds the limit of the ASME safety relief valve, it will open and vent the compressed air to atmosphere. Hand mode should normally only be used for maintenance and diagnostic activities.

The electrical control panel has terminals with dry contacts to allow showing the alarm outputs on remote alarm panels. See the wiring diagram packed in the control panel for details of connections.

The electric panel also has provision for a remote call for signal to allow multiple units to be controlled by an external alternating control panel. When the call for signal is closed the unit will run in response to the signal from the on board pressure transducer. Any unit not on call will be designated as lag and will not start unless the control signal from the alternating panel is triggered. When a unit is called into lag service, it will respond to its local pressure transducer, and due to variation in transducer calibration it may temporarily run even if the lead unit has been satisfied. The lag call is only maintained for a short time and then the lead unit will take over primary function again.

Installation

⚠ WARNING Do not operate unit if damaged during shipping, handling, or use. Damage may result in bursting and cause injury or property damage.

Receiving the Unit

Immediately upon receipt of the Powerex Scroll Compressor, the unit should be inspected for any damage which may have occurred in shipment. Any shipping damage must be immediately filed with the freight carrier.

The compressor nameplate should be checked to see if the unit is the correct model and voltage as ordered.

The unit is shipped on a heavy wooden skid with a protective crate. Duplex units may have a separate skid and crate with the dryers and other necessary components such as flex hoses. Remove the crate sides as needed. It may be useful to leave the unit mounted to the wooden skid for transport to the actual installation location. Simplex units are designed to allow fork lift access from the ends.

Duplex units can be lifted with a fork lift from the sides of the tank.

Installation Site

1. The compressor must be located in a clean, well lit and well ventilated area.
2. The area must be free of excessive dust, toxic or flammable gas, moisture or direct sunlight.
3. Ambient temperature must be maintained at less than 104°F. Avoid areas with relative humidity over 95%.
4. Clearance must allow for safe, effective access for maintenance and inspection and operation. Access on the control panel side may be controlled by NEC or other codes. Powerex recommends a minimum of 36 inches on all sides and the top.
5. If necessary, use metal shims or leveling pads to meet the tank feet. Do not use wood or other temporary material to shim the unit.

Ventilation

Room ventilation must maintain the room temperature at less than 104°F under all operating conditions. If the unit is installed in a room with general ventilation similar to Figure A, the cooling fan must be sized to generate sufficient airflow that stagnant areas are prevented. See the table below for fan flow requirements at full load operating conditions. The tables are based on the intake air being no higher than 95°F and the room temperature being allowed to rise to 104°F worst case. If the intake air is cooler or the operating duty cycle is less than 100%, reduced air flow may be sufficient. Conversely if intake air is warmer, additional ventilation will be required.

If ductwork is installed so that the warmed air from the enclosure is directly captured, as shown in figure B, flow rates as shown in table B may be sufficient.

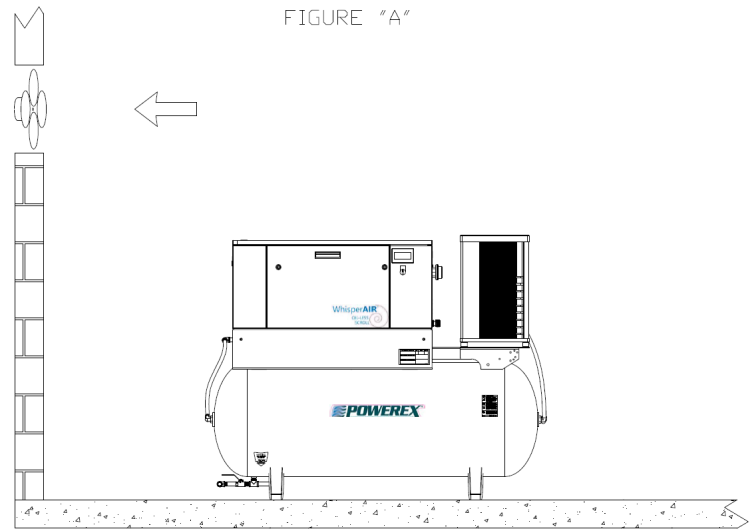

General Room Ventilation
Must allow for make-up air to enter room.

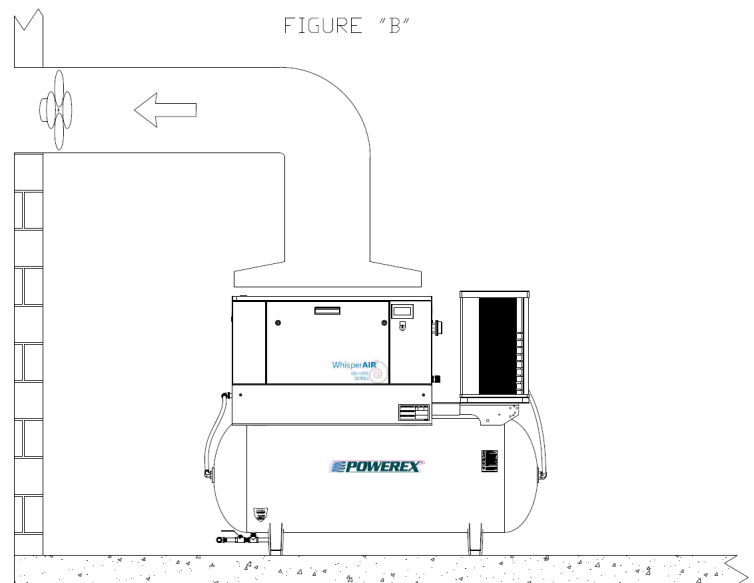

Close Duct Ventilation
Must allow for make-up air to enter room and vent must be movable for maintenance and inspection. For duplex units, a close duct must be arranged to ventilate each enclosure.

Unit Type	Room/Fan Type A	Room/Fan Type B
Simplex 7.5 HP	3,500 cfm	1,400 cfm
Duplex 7.5 HP	6,000 cfm	2,400 cfm
Simplex 10 HP	4,700 cfm	1,900 cfm
Duplex 10 HP	8,000 cfm	3,200 cfm

Mounting

The STES and STED units are intended to be secured to a solid floor. Use the air receiver mounting feet to locate and install suitable anchors. Use metal shims to avoid gaps under the feet. Install fasteners to complete mounting.

The units have internal rubber isolation mounts to minimize transmitted vibration and noise. If additional anti-vibration mounting is desired, the tank feet may be installed using Powerex supplied cork-rubber composite anti-vibration mounting pads or other materials. When installing on compressible pads, drill a hole in the pad and pass the fastener through. Tighten the fastener just enough to secure it, do not compress the pads by over tightening the fastener.

For the separately mounted dryers supplied with the STED models, follow the mounting instructions in the dryer manuals, securing them to the floor or nearby wall as desired.

Plumbing

For STES models all compressed air connecting plumbing is completed by Powerex. The outlet of the dryer is ready to connect to the facility or application. Use a flex hose connection. (Flex hoses are available from Powerex.) Models with dryers have condensate drain connection points at the water separator before the dryer and at the outlet of the automatic tank drain. Connect these to waste collection and disposal piping as needed. Make sure that disposal is accordance with all applicable regulations.

For STED models supplied with dryers, determine the desired location of the dryer and install piping from the tank outlet to the dryer inlet as needed. Use pipe size at least equal to the dryer inlet size. If the distance between the air receiver tank and the dryer is significant, use larger diameter piping. A short flex hose section for the tank outlet and one for the dryer inlet are provided with the system. Additional piping will be necessary depending on the distance selected. Connect the dryer outlet using flex connections to the facility or application. Connect condensate outlets as needed and dispose of condensate in accordance with all applicable regulations.

Remote Intake (Optional)

The STES and STED units can be piped to remote air intake points if desired. Remove the intake screen assembly and install suitable flex connections and piping to the desired remote air intake. Make sure the remote intake piping is large enough to prevent any significant pressure drop. (0.5 psi of pressure drop causes a 3% loss of compressor capacity. Maximum allowable intake pressure drop for safe operation of the pumps is 1 psig)

Electrical Connections

Three phase electric power and a ground connection of sufficient ampacity for the system must be provided. The Powerex system does not include a service disconnect or branch circuit protection.

INSTALL A FUSED DISCONNECT OR A CIRCUIT BREAKER IN THE POWER SUPPLY CIRCUIT. FOLLOW NEC OR OTHER APPLICABLE CODES FOR LOCATION OF THE DISCONNECT.

The electric panel has a terminal block/power distribution block with for the incoming conductors. A ground location is also marked on the electrical panel. Follow NEC or local codes and make sure the wires are securely connected.

The enclosure is provided with an opening to allow electric power to enter under the air inlet screen.

(On duplex units, only the entry on the enclosure with the control screen is used. The secondary unit is wired at the factory to the take power from the incoming terminal block as needed.) The conductors can be placed and secured as shown below

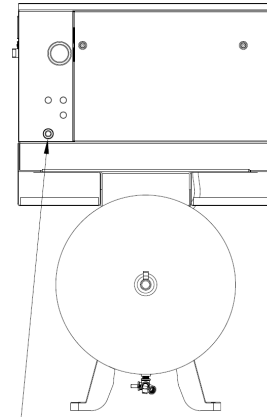

Power Inlet Location on STES

On STED, power inlet is in similar location on the enclosure set with the touch screen panel.

Install incoming 3-phase power conductors through the provided opening, using conduit or cable and appropriate strain relief or conduit connectors. Rout the conductors to the terminal block inside enclosure.

If a refrigerated dryer is installed on the system, connect the dryer to 120V AC power. A normal 15 amp circuit can easily support the dryer. The dryer condensate drain is powered from the dryer internal connections.

Start Up

1. Verify that the voltage of the supply matches the rating of the unit.
2. Make sure HAND/OFF/AUTO selector switch is in the OFF position.
3. Close service disconnect to turn on circuit breaker to apply power to the control.
4. Remove the rear access panel from the compressor enclosure so the belts and pulleys are visible.
5. Using extreme caution, make sure no one is near the belts and pulleys, bump the switch into Hand and back to Off, and observe the direction that the motor and compressor turn. Compare the direction to the arrow cast into the pump pulley (visible from the opposite side of the assembly shown below) or to the direction shown in this diagram.

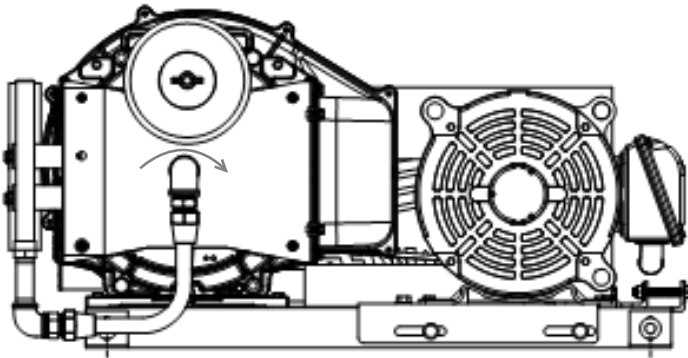

6. If rotation is correct, restore the enclosure panel to its proper position.
7. If rotation is incorrect, Lock out and tag out the power supply and switch the position of any two incoming conductors. Restore the enclosure panel to its proper position.
8. If starting a duplex unit, verify both compressor sets are rotating correctly.

The compressor is now ready for operation.

To Prepare for Normal Operation of the Unit

1. Verify the dryer and automatic tank drain have electric power.
2. Turn dryer the control switch to the On position. For desiccant dryers, if there is a Fixed/Economy switch or setting, make sure it set in Fixed. (Economy mode is used if an accessory Dew Point Monitor with a control signal is installed.)
3. Use the selector switch to place the compressor unit in Auto mode. The compressor should run and pressure in the tank will rise. When pressure reaches the preprogrammed shut off point the compressor motor will automatically stop. As compressed air is used, the pressure will drop and at the programmed cut in point the compressor will restart.

On duplex units, both compressors will run until the tank pressure rises to the lag cut out setting. One unit will continue to run until the pressure reaches the lead cut out setting. As pressure drops to the lead cut in setting, one compressor will restart. If pressure drops to the lag cut in setting, the second compressor will start. The control will automatically alternate which set is lead for each start up. If a pump is running continuously for 10 minutes, a forced alternation will occur and the other pump will start as the first pump is shut off.

4. Adjust the set points as necessary within the allowable range. The control panel navigation buttons and instructions will show the available adjustments.
5. When the air receiver has pressure in it, push the test button on the drain valve timer and verify that the tank drain opens.

NOTE: Desiccant dryers will consume compressed air to regenerate the desiccant and maintain drying capability even if there is no system demand.

Make sure there are no leaks at any compressed air connections. If leaks are detected, turn off and lock out power and vent all pressure and correct leaks.

Operation & Maintenance

Set the selector switch in Auto and allow the system to operate and supply compressed air as needed. After the first few hours check the tank to make sure no water has accumulated. If water has accumulated, increase the duration or frequency of the auto drain open time. Check for any air leaks or other problems that may have developed.

If there is no air demand for a time, turn the selector switch to Off and turn off the dryers.

Follow the maintenance chart on the next page.

Maintenance Schedule

Item	Action Needed	Operating Hours							Remarks
		500	2,000	4,000	8,000	12,000	16,000	24,000	
Pump	Replace							▲	
Tank	Drain moisture	Daily							
Inlet Air Filter	Inspect Replace	•	▲	(Every 2,500 hours or less)					Element part # VP000508AV
Blower Fan	Clean				•		•		
Fan Duct	Clean				•		•		
Compressor Fins	Clean		•	(Every 2,500 hours or less)					
Bearings	Grease				▲		▲		Service Center only
Tip Seal	Replace				▲		▲	▲	Every 8,000 hours
V-Belt	Inspect Replace		•	▲	▲	▲	▲	▲	
Pressure Switch	Confirm operation				•		•		
Magnetic Starter	Inspect				•		•		Replace if contact points deteriorated
Safety Valve	Confirm operation		•	(Every 2,500 hours or every 6 months, whichever comes first)					
Pressure Gauge	Inspect		•	(Every 2,500 hours or less)					
LEGEND									
• Inspect									
▲ Replace									

NOTICE

Maintenance frequency must be increased if ambient temperature is above 85F. For every 5F degrees above 85F reduce the time interval by 30%. After 4 years, perform tip seal and grease maintenance regardless of operating hours.

Notes:

1. Inspect and perform maintenance periodically according to maintenance schedule.
2. The maintenance schedule relates to the normal operating conditions. If the circumstances and load condition are adverse, shorten the cycle time and conduct maintenance accordingly.
3. The tension of the V-belt should be adjusted during the initial stage and inspected every 2,500 hours afterwards. Proper belt tension is just enough to prevent slippage. See following section on belt tensioning method.
4. See Compressor Pump Manuals for replacement or service procedures.

Pump Maintenance

See the detailed pump maintenance manual included in the manual set.

Adjusting Belt Tension

Belt tension is set at the factory. If slippage is detected, reset the tensions as follows:

After the first 200 to 500 running hours or at any time chirping is heard on start up, check the belt tension. If tension is below 25 pounds on any belt, increase the center distance using the motor slide base so that belt tension is 45 to 50 pounds. The motor slide base details are shown below. If installing new belts see the procedure below.

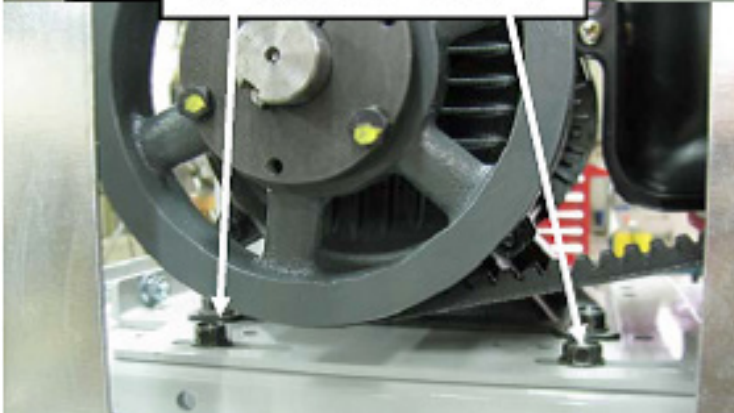
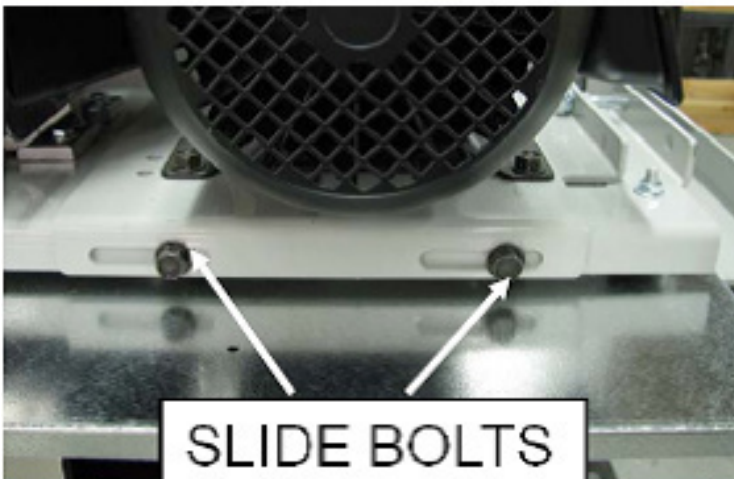
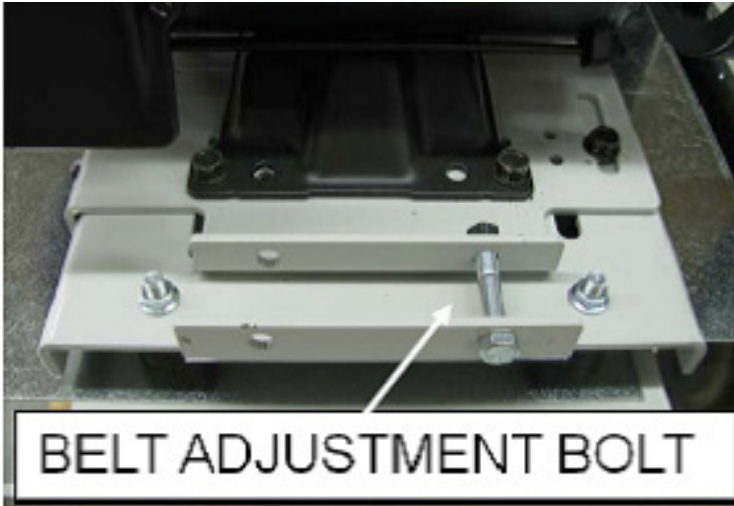

New Belt Installation Procedure

1. Loosen the two slide bolts near the motor pulley and the two slide bolts on the front edge of the base. Keep enough torque on them to take up any slack between the slider and the main base, but enough slack to allow the slider to move.
2. Tighten the belt adjustment bolt using a torque wrench to 45 inch pounds. This will bring the belts to the proper tension.
3. Tighten the slider bolts, the two on the front edge of the base, then the two slider bolts closest to the motor pulley so the belt tension is 45 to 50 pounds.



Operation & Maintenance

General Base Mount

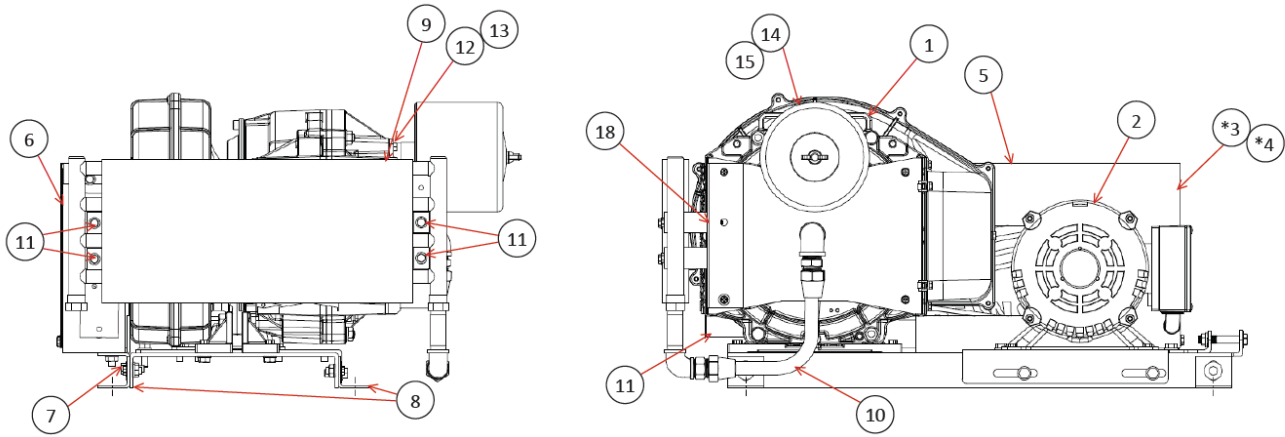

Key #	Description	7.5 HP	10 HP	Quantity
1	Pump	SL020500AV	SL021000AV	1
2	Motor 208-230/460V 60Hz 2 Pole ODP	MC304232AV	MC304234AV	1
	Motor 575V 60Hz 2 Pole ODP	MC304209AV	MC304236AV	1
	Motor 208-230/460V 60Hz 2 Pole TEFC	MC304233AV	MC304235AV	1
3	2 Groove 3V Drive Sheave with Taper Bushing (for ODP Motor)	PU202649AV	PU202648AV	1
	2 Groove 3V Drive Sheave with Taper Bushing (for TEFC Motor)	PU202651AV	PU202648AV	1
4	3VX Belt	BT024000AV	BT023900AV	2
5	Belt Guard – Back		N/A	
6	Belt Guard – Front (Wave Logo Cutout)		N/A	
7	Belt Guard Support Bracket		N/A	
8	Foot Bracket	ST185500AV	ST185500AV	4
9	After Cooler	SL309100AV	SL309100AV	1
10	Outlet Flex Hose	SM008111AV	SM008111AV	1
11	After Cooler Mounting Rubber Block	AG008300AV	AG008300AV	4
12	Inlet Air Filter Threaded Adapter	IP638900AV	IP638900AV	1
13	Inlet Air Filter Adapter Gasket	IP639000AV	IP639000AV	1
14	Inlet Filter Assembly for Remote Intake Type	VP000539AV	VP000539AV	1
15	Inlet Air Filter Element	VP000508AV	VP000508AV	1
16	Check Valve	ISO25003AV	ISO25003AV	1
17	Relief Valve	V-215100AV	V-215100AV	1
18	Pump Side After Cooler Mounting Bracket		N/A	
Parts Not Shown				
	Pressure Transducer		PE000469AV	
	Pressure Transducer Cable		PE000451AV	
	High CFM Cooling Fan		SL057006AV	
	Touch Screen /PLC		PE000468AJ	
	Temperature Switch		AM003032AV	
	Automatic Tank Drain		SL300701AV	
	Panel Latch Key		CCP00721AV	

Powerex Limited Warranty – Applicable to Non-OEM Customers in the U.S. & Canada Only

Warranty and Remedies.

(a) General. Powerex warrants each Compressor System, Vacuum System, Vacuum Pump, Compressor Air-End, or Powerex branded Accessory (collectively “Products”, individually each a “Product”) to be free from defects in material and workmanship (“Defects”) at the date of shipment. This warranty shall apply only to Products that are purchased and used in the United States of America and in Canada. EXCEPT AS SET FORTH BELOW, NO OTHER WARRANTY, WHETHER EXPRESS OR IMPLIED, INCLUDING ANY WARRANTY OF MERCHANTABILITY OR FITNESS FOR A PARTICULAR PURPOSE, SHALL EXIST IN CONNECTION WITH THE SALE OR USE OF SUCH PRODUCTS. TO THE EXTENT PERMITTED BY LAW, ANY AND ALL IMPLIED WARRANTIES ARE EXCLUDED. All warranty claims must be made in writing and delivered to Powerex in accordance with the procedures set forth on its website (www.powerexinc.com), or such claim shall be barred. Upon timely receipt of a warranty claim, Powerex shall inspect the Product claimed to have a Defect, and Powerex shall repair, or, at its option, replace, free of charge, any Product which it determines to have had a Defect; provided, however, that if circumstances are such as to preclude the remedying of Defect by repair or replacement, Powerex shall, upon return of the Product, refund to buyer any part of the purchase price of such Products paid to Powerex. Freight for returning Products to Powerex for inspection shall be paid by buyer. The warranties and remedies herein are the sole and exclusive remedy for any breach of warranty or for any other claim based on any Defect, or non-performance of the Products, whether based upon contract, warranty or negligence.

(b) (i) Standard Period of Warranty – Parts and Labor. The purchase of any system includes our standard warranty. Powerex warrants and represents all Products shall be free from Defects for the first eighteen (18) months from the date of shipment by Powerex, or twelve (12) months from the documented date of startup, or five thousand (5,000) hours of use, whichever occurs first. During such warranty period, Powerex shall be fully liable for all Defects in the Products (the “Product Defects”), i.e., all costs of repair or replacement, which may include “in and out” charges, so long as the Products are located in the United States or Canada, and the Products are reasonably located and accessible by service personnel for removal. “In and out” charges include the costs of removing a Product from buyer’s equipment for repair or replacement.

(ii) Premium Period of Warranty – Parts and Labor. In order to be eligible for premium warranty coverage, a premium warranty for each system must be purchased when order is placed. Powerex warrants and represents all Products shall be free from Defects for the first thirty (30) months from the date of shipment by Powerex, or twenty-four (24) months from the documented date of startup, or seven thousand five hundred (7,500) hours of use, whichever occurs first. During such warranty period, Powerex shall be fully liable for all Defects in the Products (the “Product Defects”), i.e., all costs of repair or replacement, which may include “in and out” charges, so long as the Products are located in the United States or Canada, and the Products are reasonably located and accessible by service personnel for removal. “In and out” charges include the costs of removing a Product from buyer’s equipment for repair or replacement.

(c) Additional Period of Warranty – Parts Only (No Labor). In addition to the above, Powerex warrants each Powerex branded Compressor Air-End and Vacuum Pump shall be free of Defects for a period of forty-two (42) months from the date of shipment by Powerex, or thirty-six (36) months from the documented date of startup, or ten thousand (10,000) hours of use, whichever occurs first. Supplier’s repair or replacement of any Product shall not extend the period of any warranty of any Product. This warranty applies to the exchange of part(s) found to be defective by an Authorized Powerex Service Representative only.

(d) Replacement Pumps – Parts Only (No Labor). For any replacement Air-End or Vacuum Pumps installed on a Powerex manufactured system or unit after any initial warranty period has expired or where another warranty does not apply for any reason, Powerex warrants that the Air-End or Vacuum Pumps shall be free of Defects for a period of thirty-six (36) months from the date of shipment by Powerex or ten thousand (10,000) hours of use, whichever comes first. For any replacement Air-End or Vacuum Pumps installed on a system that was not manufactured by Powerex after any initial warranty period has expired or where another warranty does not apply for any reason, Powerex warrants that the Air-End or Vacuum Pumps shall be free of Defects for the first twelve (12) months from the date of shipment by Powerex. Supplier’s repair or replacement of any Product shall not extend the period of any warranty of any Product. This warranty applies to the exchange of part(s) found to be defective by an Authorized Powerex Service Representative only.

(e) Replacement Motors – Parts Only (No Labor). For any replacement motor installed on a Powerex manufactured system or unit after any initial warranty period has expired or where another warranty does not apply for any reason, Powerex warrants that the replacement motor shall be free of Defects for the first twelve (12) months from the date of shipment by Powerex. For any replacement motor installed on a system or unit that was not manufactured by Powerex after any initial warranty period has expired or where another warranty does not apply for any reason, Powerex warrants that the replacement motor shall be free of Defects for the first ninety (90) days from the date of shipment by Powerex. Supplier’s repair or replacement of any Product shall not extend the period of any warranty of any Product. This warranty applies to the exchange of part(s) found to be defective by an Authorized Powerex Service Representative only.

(f) Replacement Parts – Parts Only (No Labor). For other replacement parts besides motors, Air-End or Vacuum Pumps installed on a Powerex manufactured system or unit after any initial warranty period has expired or where another warranty does not apply for any reason, Pow-

Powerex warrants that such replacement parts will be free from Defects for the first twelve (12) months from the date of shipment by Powerex. For other replacement parts besides motors, Air-End or Vacuum Pumps installed on a system or unit that was not manufactured by Powerex after any initial warranty period has expired or where another warranty does not apply for any reason, Powerex warrants that such replacement parts will be free from Defects for the first twelve (12) months from the date of shipment by Powerex. For other replacement parts besides motors, Air-End or Vacuum Pumps installed on a system or unit that was not manufactured by Powerex after any initial warranty period has expired or where another warranty does not apply for any reason, Powerex makes no warranties. Supplier's repair or replacement of any Product shall not extend the period of any warranty of any Product. This warranty applies to the exchange of part(s) found to be defective by an Authorized Powerex Service Representative only.

(g) Coverage. The warranty provided herein applies to Powerex manufactured units or systems only.

(h) Exceptions. Notwithstanding anything to the contrary herein, Powerex shall have no warranty obligations with respect to Products:

- (i)** That have not been installed in accordance with Powerex's written specifications and instructions;
- (ii)** That have not been maintained in accordance with Powerex's written instructions;
- (iii)** That have been materially modified without the prior written approval of Powerex; or
- (iv)** That experience failures resulting from operation, either intentional or otherwise, in excess of rated capacities or in an otherwise improper manner.

The warranty provided herein shall not apply to: **(i)** any defects arising from corrosion, abrasion, use of insoluble lubricants, or negligent attendance to or faulty operation of the Products; **(ii)** ordinary wear and tear of the Products; or **(iii)** defects arising from abnormal conditions of temperature, dirt or corrosive matter; **(iv)** any OEM component which is shipped by Powerex with the original manufacturer's warranty, which shall be the sole applicable warranty for such component.

Limitation of Liability. NOTWITHSTANDING ANYTHING TO THE CONTRARY HEREIN, TO THE EXTENT ALLOWABLE UNDER APPLICABLE LAW, UNDER NO CIRCUMSTANCES SHALL POWEREX BE LIABLE FOR ANY INCIDENTAL, CONSEQUENTIAL, PUNITIVE, SPECULATIVE OR INDIRECT LOSSES OR DAMAGES WHATSOEVER ARISING OUT OF OR IN ANY WAY RELATED TO ANY OF THE PRODUCTS OR GOODS SOLD OR AGREED TO BE SOLD BY POWEREX TO BUYER. TO THE EXTENT ALLOWABLE UNDER APPLICABLE LAW, POWEREX'S LIABILITY IN ALL EVENTS IS LIMITED TO, AND SHALL NOT EXCEED, THE PURCHASE PRICE PAID.

Warranty Disclaimer. Powerex has made a diligent effort to illustrate and describe the Products in its literature, including its Price Book, accurately; however, such illustrations and descriptions are for the sole purpose of identification, and do not express or imply a warranty that the Products are merchantable, or fit for a particular purpose, or that the Products will necessarily conform to the illustrations or descriptions.

Product Suitability. Many jurisdictions have codes and regulations governing sales, construction, installation, and/or use of Products for certain purposes, which may vary from those in neighboring areas. While Powerex attempts to assure that its Products comply with such codes, it cannot guarantee compliance, and cannot be responsible for how the product is installed or used. Before purchase and use of a Product, please review the Product applications, and national and local codes and regulations, and be sure that the Product, installation, and use will comply with them.

Claims. Any non-warranty claims pertaining to the Products must be filed with Powerex within 6 months of the invoice date, or they will not be honored. Prices, discounts, and terms are subject to change without notice or as stipulated in specific Product quotations. Powerex shall not be liable for any delay or failure arising out of acts of the public enemy, fire, flood, or any disaster, labor trouble, riot or disorder, delay in the supply of materials or any other cause, whether similar or dissimilar, beyond the control of Company. All shipments are carefully inspected and counted before leaving the factory. Please inspect carefully any receipt of Products noting any discrepancy or damage on the carrier's freight bill at the time of delivery. Discrepancies or damage which obviously occurred in transit are the carrier's responsibility and related claims should be made promptly directly to the carrier. Returned Products will not be accepted without prior written authorization by Powerex and deductions from invoices for shortage or damage claims will not be allowed. **UNLESS OTHERWISE AGREED TO IN WRITING, THE TERMS AND CONDITIONS CONTAINED IN THIS LIMITED WARRANTY WILL CONTROL IN ANY TRANSACTION WITH POWEREX.** Any different or conflicting terms as may appear on any order form now or later submitted by the buyer will not control. All orders are subject to acceptance by Powerex.