

General

The Powerex medical vacuum system is designed to create a suction system to remove unwanted fluids or gases from hospital/ laboratory working areas. The medical vacuum system package is compliant with the NFPA 99 requirements for Risk Category 1 systems. Each system is completely tested before shipment and includes:

- Multiple vacuum pumps and associated equipment.
- AMSE air receiver.
- Medical control panel.

Each pump is factory piped to a common intake manifold. Vibration isolation pads are included with the system.

Oilless Dry Rotary Vane Vacuum Pump

Each pump shall be a dry rotary vane type vacuum pump, and shall be direct-driven through a shaft coupling by a C-face, TEFC electric motor.

- Each vacuum pump shall be dry-running, featuring self-lubricating carbon/graphite vanes and shall not require any sealing fluid in the pumping chamber.
- Each vacuum pump shall include an internal relief valve, a check valve, inlet and discharge flex connectors, a 5 micron inlet filter and a pump isolation valve.

Motor

The motor is continuous duty, C-face, TEFC, suitable for 208-230, or 460V, 3 phase, 60 hertz electrical operation.

Air Receiver

The system shall include an ASME rated air receiver. The tank shall be equipped with a sight gauge, by-pass valves, and a manual drain.

Premium NFPA Control Panel

The control system provides automatic lead/lag sequencing and automatic alternation of all pumps in order to equalize the amount of usage among the available vacuum pumps. The Premium NFPA Control panel shall include a gateway server card and all features listed below:

- PLC controller and a color touch screen panel which displays the operating status of the unit.
- Building automation communication gateway with BacNet® protocol.
- Ethernet port for connection to BacNet® server or direct connection to facility Ethernet for viewing of system operations and status via device IP-address.
- UL508A listed control panel in a NEMA 12 enclosure. The panel door will include: the HMI touch screen, an audible and visual alarms with an acknowledge button, and an HOA switch for each pump.
- Magnetic starters.
- Vacuum transducer for process control.
- Single point power connection.
- Redundant 120Vac control transformers with fused primary and secondary protection.
- System overload trip, high temperature conditions or maintenance intervals for the pump will result in visual and audible alarms.

Available Options

- Internal tank lining for corrosion resistance.

Dimensions					
Model	Dim. A	Dim. B	Dim. C	Inlet	Outlet
WOTD0303	35.5"	54.5"	79.0"	1 1/2"	1 1/2"
WOTD0404	35.5"	54.5"	79.0"	1 1/2"	1 1/2"
WOTD0504	35.5"	54.5"	79.0"	1 1/2"	1 1/2"

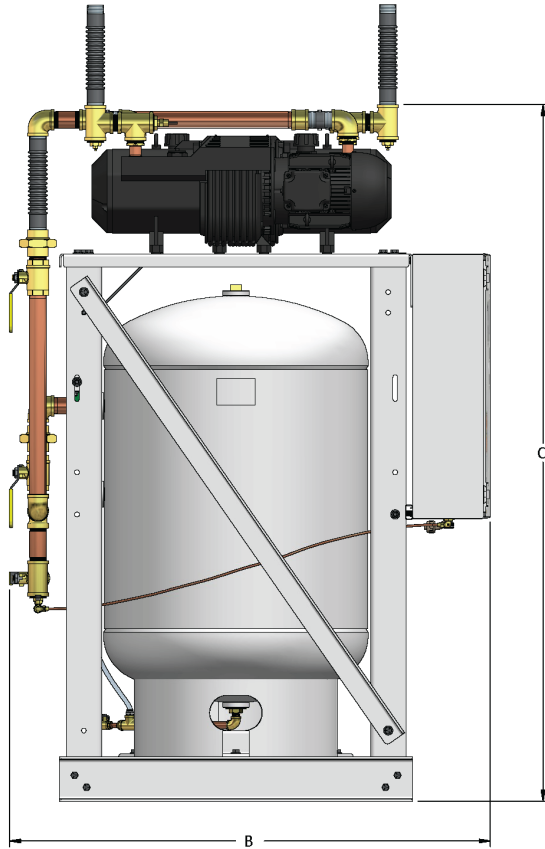
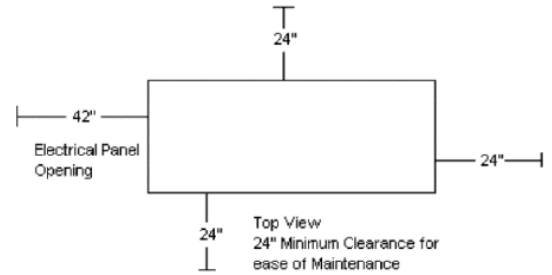

Oil-less Medical Vacuum Package with Premium Controls										
Model	HP	SCFM @ 19" Hg	NFPA System Capacity	Tank Size (gal)	BTU/ Hr(2)	dB(A) Level (3)	System F.L.A.			System Weight (lbs)
							208V	230V	460V	
WOTD0303	3	13.5	13.5	80V	7,638	76	19.8	18.4	10.2	1144
WOTD0404	4.0	17	17	120V	12,730	77	28.8	26.8	14.4	1334
WOTD0504	5.4	21	21	120V	12,730	76	33.4	31.6	16.8	1467

Notes:

- 1 – System Capacity is shown with one or more pumps in reserve per NFPA 99.
- 2 – BTU/Hr levels are shown with reserve compressor(s) on standby.
- 3 – dB(A) levels are shown with one compressor in reserve.
- 4 – 3 Year Limited Warranty.