

Enclosed Vacuum Operating & Maintenance Manual

Please read and save these instructions. Read carefully before attempting to assemble, install, operate or maintain the product described. Protect yourself and others by observing all safety information. Failure to comply with instructions could result in personal injury and/or property damage! Retain instructions for future reference.

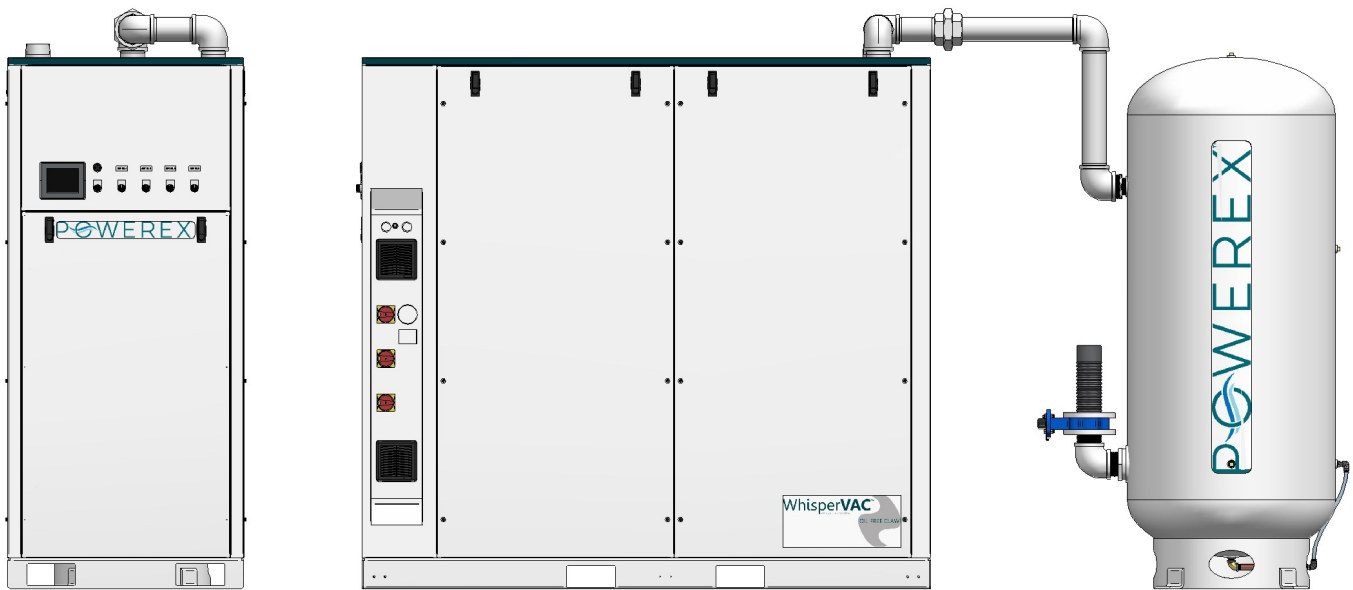

Description

General

Powerex Enclosed Vacuum Systems are designed to provide vacuum for hospitals, laboratories and other facilities. The vacuum pumps are contained in one or more sound reducing enclosures and include the required operating controls for the contained vacuum pumps. Multiple enclosures communicate as required so that the internal controls can operate the contained pumps for each enclosure. The system will have a vacuum receiver and other auxiliary devices as needed for the application. NOTE: IF used for WAGD in medical facilities, the system must be configured as required by NFPA 99 to maintain the concentration of oxidizers below 23.6 percent or the pumps shall be designed of materials and using lubricants that are inert in the presence of oxygen, nitrous oxide, and halogenated anesthetics.

Safety Guidelines

This manual contains information that is very important to know and understand. This information is provided for SAFETY and to PREVENT EQUIPMENT PROBLEMS. To help recognize this information, observe the following symbols.

⚠ DANGER Danger indicates an imminently hazardous situation which, if not avoided, WILL result in death or serious injury.

⚠ WARNING Warning indicates a potentially hazardous situation which, if not avoided, COULD result in death or serious injury.

⚠ CAUTION Caution indicates a potentially hazardous situation which, if not avoided, MAY result in minor or moderate injury.

NOTICE Notice indicates important information, that if not followed, may cause damage to equipment.

NOTE: Note indicates information that requires special attention.

Unpacking

Immediately upon receipt of the vacuum system, inspect for any damage which may have occurred during shipment. Repair or replace damaged items before use. The name-plate should be checked to verify the correct model and voltage.

⚠ WARNING Do not operate unit if damaged during shipping, handling or use. Damage may result in unsafe conditions and cause injury or property damage.

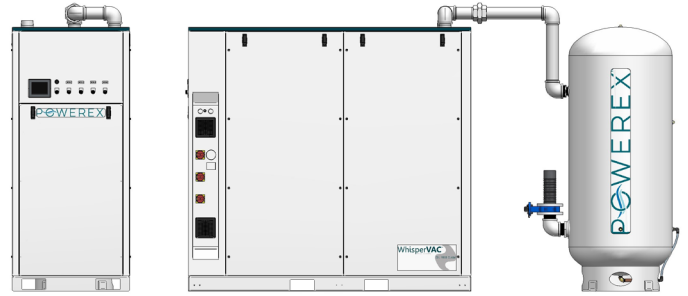

MVECD1505

SPECIFICATIONS		
Product	MVECD, MVECT, MVECQ, MVECP, MVECH, MVEC-EX, MVEV, LVECD, LVECT, LVECQ, LVECP, LVECH, LVEV	
Operating Voltages	208V, 230V, 460V	
Control Panel	UL508A and NFPA compliant	
Motor	TEFC Electric Motor	
Tank	ASME Rated for 200 psi MAWP Suitable for full vacuum	
Drive	Direct	
Tank Sizes	80 gal, 120 gal, 200 gal, 240 gal	
Performance	See Cut Sheet	
Inlet/Outlet Connection Size (Enclosure)	Small Claw Enclosure	2" / 2" MNPT
	Large Claw Enclosures	3" / 2" MNPT
	Lube Vane Enclosures	2" / 2" MNPT

Lifting

The Powerex Enclosed Vacuum system is shipped on a wooden pallet and a crate. Use an appropriate fork lift to move the pallet. When necessary remove the crate and dispose of it.

If hidden damage is detected when the crate is removed, document the conditions and contact the responsible carrier. If the system is supplied with a receiver tank, it too will be mounted to a wooden pallet and protected by a crate.

The unit may be removed from the pallet for transport to its installation site. Fork lift openings are provided in the base platform assembly. Be sure to protect the sheet metal panels and the control panel so they are not damaged if lifting from the fork slots. Use extreme caution when moving a receiver tank.

When lifting the unit, slings may be rigged through the fork lift openings in necessary. Use spreader bars and pads to prevent damage to the sheet metal enclosure.

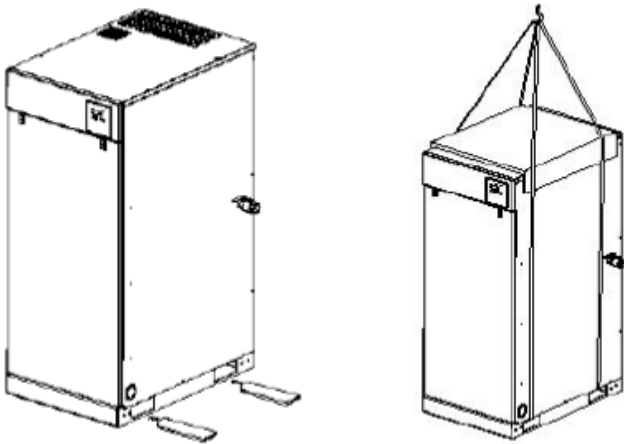

Components

Powerex Enclosed Vacuum pump units consist of multiple vacuum pump-motor assemblies, the valves and piping to connect them, cooling fans and ducts, intake particulate filters, and the controls needed to operate the enclosed equipment. Everything is contained in an easily accessible sound reducing cabinet.

When configured as Medical Vacuum Systems from Powerex, one pump or group of pumps will be designated as a reserve per NFPA99 requirements. In systems configured for laboratory or other vacuum applications all pumps are available for normal use.

Vacuum Pumps

The vacuum pumps are designed to remove gases and

vapors and are not intended to pump liquids or solids. The provided 5 micron particulate filters serve as a final level of protection to protect the pumps from solid particles in the air stream. The filters are not capable of removing liquids or condensed gases and appropriate liquid, and bulk solid removal equipment must be installed in the vacuum line ahead of the Powerex unit.

The vacuum pumps each have their own motor. The pumps and motors are connected by a flexible element coupling where a fan is incorporated into one of the coupling hubs. The fan provides for cooling of the pump itself. A check valve is incorporated into the piping for each pump as is an isolation valve. Each Oilless Claw type pump has an exhaust silencer and a vacuum relief valve that prevents the pump from operating at vacuum levels deeper than the design capability. Lubricated Vane type vacuum pumps do not require relief valves or separate exhaust silencers. The vacuum relief valves are adjusted for normal nearly sea level operation and Powerex will adjust them to appropriate settings if altitude is above 3000 feet if requested at the time of purchase. If field adjustment must be performed contact Powerex for instructions. Intake isolation valves are supplied for use when a pump is under maintenance or repair. To isolate the exhaust piping, install a suitable cap or plug on the exhaust stub line after removing the pump. Each vacuum pump is isolation mounted to the internal framework.

Vacuum Receiver Tank

The Powerex Enclosed Vacuum system has an intake port for connection to the facility to a vacuum system that includes appropriate piping and should include a vacuum receiver tank. The vacuum receiver tank is provided by Powerex if the module is part of a Powerex configured system. For ease of maintenance and service, an isolation valve or bypass valves should be present. If the Vacuum Receiver Tank is provided by Powerex it will be an ASME National Board registered vessel and will provided with an isolation valve, a manual drain and sight gauge. Optional automatic drain is available. Vacuum Receivers for Laboratory systems have anti-corrosion internal linings and are optional for Medical applications.

Controls

The Powerex Enclosed Vacuum system has an integrated electrical control section that includes a three phase incoming power terminal block, dual control transformers, a PLC with a touch screen interface and a vacuum transducer and power supply. All versions have lockable motor protectors. VFD control of the lead

vacuum pump-motor is offered. Medical models have Reserve Pump In Use warning and provision for wiring to facility master alarm panels as required by NFPA99.

Accessories

The enclosure comes with an exhaust silencer sized for the vacuum flow of the internal pumps. For best results install it as close to the exhaust connection on the enclosure as possible. For installations complying with NFPA99, the exhaust flow must be piped to an outlet located and protected as specified in the standard. For laboratory or industrial applications, a suitable location for the exhaust outlet must be selected.

Claw systems are shipped with exhaust piping final silencers. These pipe like devices utilize sound absorbing materials to reduce resonances in the exhaust piping after the flow leaves the enclosure. The exhaust silencer can be mounted vertically or an elbow can be installed allowing horizontal installation. It can be placed before or after the flexible connector.

Cork rubber composition vibration isolation pads for placement under the corners and mounting brackets may be purchased separately from the enclosure.

Location and Installation

The Powerex Enclosed Vacuum is intended for indoor or protected installation where the temperature is controlled to be between 34F and 104°F. Sufficient ventilation must be provided to prevent the room or area around the unit from heating up due to heat generated during operation. The space in front of the control panel must be unobstructed be sufficient to meet the requirements of National Electric Code for electrical panels. Space on the sides, back and top of the unit must be sufficient to allow access for removal of the side panels and access for routing maintenance and repairs. A minimum of 36 inches on the sides and 24 inches on top is recommended.

Ventilation and cooling selection is dependent on many variable including room size and configuration, and allowable room temperature rise and vacuum system duty cycle. The ventilation flow values in table 1 are based on a 4000 cubic foot room with outdoor air at no higher than 95F being used for room make up air and the product operating at full load. If cooler air is supplied, duty cycle is reduced or the room is larger, lower flow values may be feasible. Room temperature must be maintained at less than 104°F (preferably less than 90F for reduced maintenance requirements) and a qualified HVAC engineering firm should be consulted if necessary.

If generalized room ventilation is used similar to diagram A below; the ventilation air flow should be at least the amount shown in Table A. If ducting is arranged as shown in diagram B, the ventilation airflow shown in table B can be used as minimum value. In all cases it is important to assure that warmed cooling air is not recirculated to the cooling air intake near the lower front of the unit. Care must be exercised so that warmed air from other equipment is not directed into the cooling air intakes.

Ventilation for Enclosed Vacuum systems should be based on the maximum number of pumps that may be running at one time.

Use Tables 1 and 2 to determine the minimum required ventilation for each system when the maximum number of pumps is running. Note that medical systems always have a reserve pump that is only used in an emergency; standard system CFM for medical units does not include this pump. Example: Medical 5 HP Duplex system = 1 pump running, 1 in reserve, 750 CFM ventilation required with 75°F air; Lab 5 HP Duplex system = 2 pumps running, 1500 CFM Ventilation required with 75°F air.

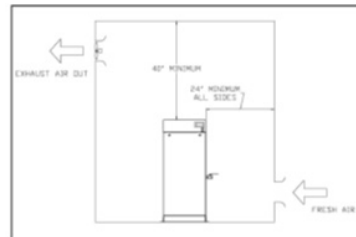

Diagram A

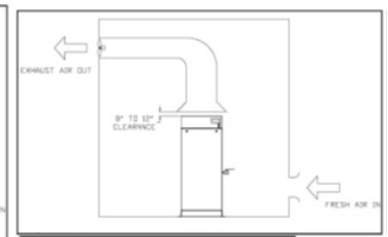

Diagram B

Table 1: Exhaust CFM/pump required using 99°F outdoor air for makeup

Pump HP	Ventilation Type	
	CFM Setup A	CFM Setup B
5	3700	2500
7 & 7.5	5000	3500
10	7400	5000
15	10000	7000

Table 2: Exhaust CFM/pump required using 75°F air for makeup

Pump HP	Ventilation Type	
	CFM Setup A	CFM Setup B
5	750	500
7 & 7.5	1000	700
10	1500	1000
15	2000	1400

Installation

⚠ WARNING Disconnect, tag and lockout power before attempting to install, service, relocate or perform any maintenance.

⚠ CAUTION Do not lift or move unit without appropriately rated equipment. Be sure the unit is securely attached to lifting device used. Do not lift unit by holding onto tubes or coolers. Do not use pumps to lift other attached equipment.

⚠ WARNING Installation of inlet / outlet air plumbing from the system and electrical connections must be in accordance with National Fire Protection Association (NFPA99) Code Compliance for Medical Gas Breathing Air (Level 1).

⚠ WARNING

RISK OF ELECTRIC SHOCK AND INJURY

Multiple supply sources. Always disconnect VFD and motor circuit before servicing.

Multiple pump Vacuum System controls with Variable Frequency Drive have multiple sources of supply for the electric power. To eliminate the risk of electric shock and injury while performing service on any of the pump-motors, always disconnect, lock out and tag out the main motor circuit and the VFD supply circuit. Failure to disconnect and secure both circuits could allow the pump motor to start during the service activity and may lead to electric shock and injury.

Installation Site

1. The vacuum system must be located in a clean, well lit and well ventilated area.
2. The area should be free of excessive dust, toxic or flammable gases and moisture.
3. Never install the vacuum system where the surrounding temperature is higher than 104°F or where humidity is high.
4. Clearance must allow for safe, effective inspection and maintenance.

MINIMUM CLEARANCES

Above	24 inches
Other sides	36 inches

5. If necessary, use metal shims or leveling pads to level the system. Never use wood to shim the unit.
6. The frame is drilled to allow bolting to the floor. Secure it as necessary. Optional rubber composite isolation pads may be used to minimize transmission of noise and vibration to the building. Pumps are

factory isolated from the frame of the system, using additional isolation is allowable but not required. Additional measures for isolation may be required. Drill a hole through the isolation pad and center it under the mounting point.

7. Some systems are built with multiple frames and must be installed and the air and electrical connections between the frames made at the time of installation. Be sure to install the system in the same configuration as shown on the system drawing so that the flexible connection hoses and electrical lines will fit.

Ventilation

1. If the vacuum system is located in a totally enclosed room, an exhaust fan with access to outside air make up air must be installed.
2. Never restrict the cooling fan exhaust air. Maintain the clearance listed above.
3. Never locate the vacuum system where hot exhaust air from other heat generating units may be pulled into the unit.

Wiring

⚠ DANGER Lock out and tag out the electrical supply before servicing the equipment.

⚠ DANGER Electrical shock hazard. Make sure the system is grounded in accordance with NEC and local requirements.

All electrical hook-ups must be performed by a qualified electrician. Installations must be in accordance with local and national electrical codes. Make sure power supply conductors are sized adequately for full system demand.

OSHPD Seismic Installation

For seismic installations complying with OSP-0393, all external panels are required to be secured. A seismic fastener kit is supplied with all vacuum enclosures for installation after initial system start-up. Fasteners should be installed at designated panel locations and only removed when internal access is necessary. Throughout standard operation, it is required that external panels remain securely fastened.

Intake/Exhaust Piping

The system intake piping will most likely be determined by the facility flow requirements. If no other sizing information is available make the intake piping at least one size larger than the exhaust piping as determined in the following charts and tables.

internal drip leg's can then be drained at less frequent intervals determined after operating experience with the system is gained.

NOTICE

The Powerex Vacuum System is not intended to pass liquids or solids. Make sure the intake system and equipment are able to effectively remove liquids and solids before reaching the system. Liquids and solids entering the pumps will cause damage and pump failure.

1. Make sure the piping is lined up without being strained or twisted when assembling the piping for the system.
2. The exhaust piping should be kept as short and have the least restriction possible. The flex connector supplied by Powerex may be repositioned (changed from vertical to horizontal and the elbow turned or removed) if desired to achieve a more effective installation to match the field installed exhaust piping. Repositioning is desirable if the final system plumbing design can be shorter by doing so.
3. Never use any piping smaller than the pump connection. To determine the minimum required pipe size for a vacuum system exhaust, calculate the equivalent straight length of the run. Never use a pipe size smaller than the flex connector supplied by Powerex or smaller than the size shown in the 100 foot column on the chart for the CFM of the pump. The equivalent straight length is the length of all the pipe needed from the flex connector to the final outlet plus a factor for each elbow, cross or tee. Pipe must be smooth ID. If rough pipe is used, increase by one size.
4. If a grating or grille is used at the end of the exhaust pipe, make sure its open area is at least equal to the area of the exhaust pipe.

The enclosure has a single point plumbing exhaust exiting at the top rear of the enclosure. A flexible connector is supplied to connect it to the facility exhaust line. The exhaust silencer is intended for installation in the exhaust line, near the enclosure exit.

Each pump's exhaust plumbing contains a drip leg to prevent condensed exhaust gases from draining back into the pump. A facility drip leg should be installed external to the enclosure so that bulk liquid can easily be drained from the exhaust line without opening the enclosure. The

PIPE SIZE REQUIREMENTS			
System CFM	Minimum Pipe Size for 100 feet	Minimum Pipe Size for 300 feet	Minimum Pipe Size for 600 feet
5	1.0	1.25	1.5
7	1.0	1.25	1.5
11	1.25	1.5	1.5
21	1.25	1.5	1.5
26	1.25	1.5	2.0
32	1.25	1.5	2.0
38	1.5	2.0	2.5
52	1.5	2.0	2.5
58	1.5	2.5	2.5
63	2.0	2.5	2.5
65	2.0	2.5	3.0
87	2.0	2.5	3.0
104	2.0	3.0	3.5
111	2.5	3.0	3.5
154	2.5	3.0	3.5
156	2.5	3.5	4.0
168	2.5	3.5	4.0
195	3.0	3.5	4.0
258	3.0	3.5	4.0
260	3.5	4	5.0
387	3.5	4	5.0
516	4	5	6.0

If the system extends beyond 600 equivalent straight feet, use one size larger pipe.

Pipe Size	Equivalent length for 90° elbow, cross, or tee	Equivalent length for 45° elbow
	3.0 feet	1.5 feet
1.5	3.75 feet	1.8 feet
2.0	5.0 feet	2.5 feet
2.5	6.25 feet	3.1 feet
3.0	7.5 feet	3.8 feet
3.5	8.78 feet	4.4 feet
4.0	10.0 feet	5.0 feet
5.0	12.5 feet	6.25 feet

Approximate system CFM equals the number of pumps running times CFM in table below. (Data below is for reference only, if actual pump CFM is higher than shown, use the higher value.)		
HP	Vane Pump CFM @ 19"	Claw Pump CFM @ 19"
1.0	2.0	
1.5	7	
2.0	11	16
3.0	17	21
4.0		29
5.0	26	
5.0	38	
5.4		38
6.4		52
7.5	52	65
8.7		77
10.0	65	84
10.0	77	
15.0	111	129
20.0	137	
25.0	168	

Primary-Subordinate Control

Powerex multi-enclosed vacuum systems utilize Ethernet connectivity to communicate over a closed control network. Each enclosure houses up to three pumps. When multiple enclosures are needed, they are separated into Primary and Subordinate enclosures. Each system consists of a single primary enclosure and a number of subordinate enclosures. Primary enclosures include a PLC controller, HMI, optional VFD, vacuum transducer, and associated power and control circuits, as well as an unmanaged industrial Ethernet switch. Subordinate enclosures include a PLC controller, optional

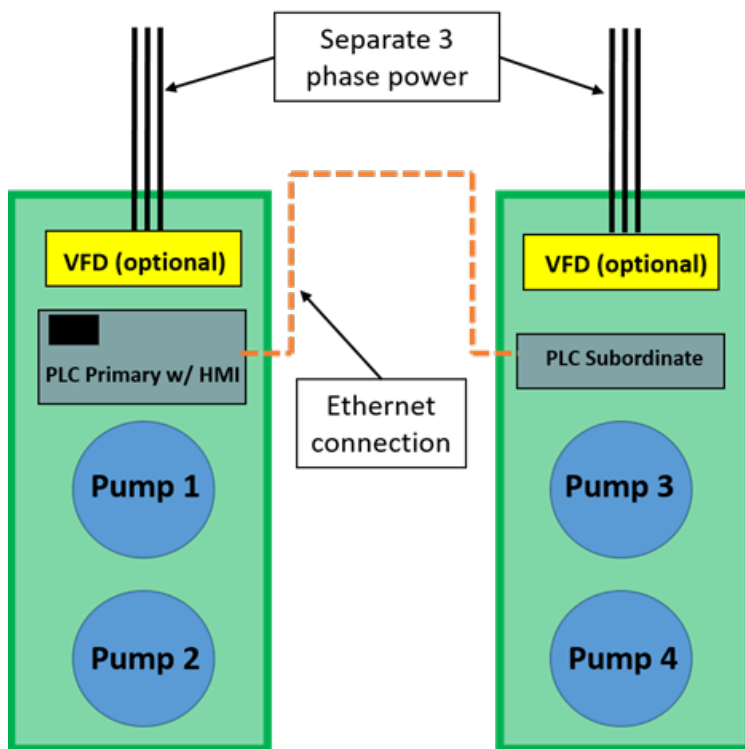

VFD, power and control circuits, and a backup vacuum switch. Each subordinate enclosure ships with a 50ft Ethernet cable.

Ethernet connections between enclosures run from the Ethernet port on the PLC of the subordinate to the Ethernet switch in the primary. Enclosures are powered by individual supply and can be oriented as needed in the installation site. The control logic uses Modbus TCP to establish communications between the primary and subordinate(s). Subordinate enclosures ship with a dedicated IP address set at the Powerex factory. During start up, all that is needed is to connect the enclosures via Ethernet and power them up. The primary enclosure will scan the network for subordinates and indicate

connection status on the main screen.

If connection is lost between a primary and its subordinate(s) for any reason (i.e. communications or power failure), the enclosures are designed to continue operation independently. If a failure occurs at a subordinate enclosure, the primary continues to operate and throws a lost connection fault. If a failure occurs at the primary, all subordinates in the system go into failsafe mode. In failsafe mode, the subordinate employs a backup vacuum switch with predetermined set points to maintain operation. Once communications have been reestablished, the primary takes control of the subordinate(s) automatically and returns to normal operation.

Operation

Before Start Up

1. Make sure all safety warnings, labels and instructions have been read and understood before continuing.
2. Remove any shipping materials, brackets, etc.
3. Ensure all fuses, circuit breakers, etc., are properly sized.
4. Verify that all pumps have the proper amount of oil in them for operation. The claw type vacuum pumps require oil in the gear boxes. See the enclosed manual from the pump manufacturer for correct oil type to use.
5. Confirm electric power source and ground have been firmly connected. Make sure the electrical control box door is closed and latched.
6. Make sure inlet filter is properly installed and all piping is connected. Open the isolation valves for each vacuum pump. Open the valve to the receiver. Close the receiver drain valve.
7. Make sure all selector switches on the control panel are OFF.

⚠ WARNING Risk of injury. Make sure no one in contact with any moving parts during the rotation check.

8. Check that all fuses, circuit breakers, etc., are the proper size.
9. Using the hand mode, briefly turn on one of the pumps while observing any visible part of the fan or coupling assembly. Verify the shaft is turning in the correct direction. Do the same for the other pump. If for some reason no visual observation is

possible, close the isolation valve between the unit and the tank, briefly turn the unit on and determine if vacuum is developed. If no vacuum is observed within a few seconds, it is likely the rotation is reversed.

10. If reverse rotation is detected on all pumps, switch position of two incoming power conductors. If one is running backwards, switch position of two conductors at the load side of the motor contactor.

NOTICE

If all pumps are running in the wrong direction, change the incoming power leads to correct rotation.

NOTICE

On some claw vacuum pumps, the fan is powered by a separate motor. The fan rotation direction may be different from the main shaft rotation direction.

Start Up and Operation

1. Follow all procedures under “Before Start-Up” before attempting operation of the vacuum pump.
2. Make sure all selector switches are in the OFF position.
3. Switch on electric source.
4. Open tank connection valve or valves completely.
5. Using the selector switches on the control panel, turn on each pump – motor in the “Auto” mode until all are running.
6. Check the vacuum level using the system gauge or display. The control system will turn off the vacuum pump motors when the vacuum level is maintained and the minimum run timer conditions are satisfied.
7. Check for excessive vibration, unusual noises or leaks during operation. If problems are detected, shut down the system and make corrections or repairs as needed before operating the system.
8. Pumps may be operated in “Hand” mode to override the function of the automatic controls. The pumps and the system will not be damaged during “hand” mode operation. The pumps are equipped with automatic vacuum limiting valves if needed to avoid damage.
9. In normal operation, leave all selector switches in the “Auto” position and allow the controls to cycle the pumps as needed based on vacuum demand.

NOTICE

Switch breaker OFF if vacuum pump will not be used for a long period of time.

Sequence of Operations
Medical Vacuum Systems

The control system uses a vacuum transducer to determine the level of vacuum in the system. If the vacuum level is insufficient to satisfy the program criteria, one or more vacuum pumps are energized to run. When the vacuum condition satisfies the criteria, the pump is de-energized if possible or if the 10 minute minimum run has not yet been satisfied, the remaining time is run out and then the pump is de-energized. The minimum run timer prevents motor overheating and excess wear on the mechanical parts of the system. While the pump is running on the minimum run timer, if system demand for vacuum is low, the vacuum level will reach the maximum pump capability. If the pump requires a vacuum relief valve, it will automatically operate during the sequence.

The control system has a built a 30 minute lead-lag alternation timer to equalize usage of the pumps. In NFPA99 systems, the lag pump is designated as a reserve and if it is called upon, the system will generate a signal for a remote alarm as well as generating a local audible and visual warning. The alternation time in Medical systems is 30 minutes. If a pump is engaged and the minimum run timer is active, the alternation sequence will be delayed until the minimum run timer is satisfied.

Each pump has a high temperature sensor and each pump motor has a motor protector circuit breaker. If the high temperature sensor detects that the pump exhaust flow is higher than the limit temperature, that pump will be shut down and local and remote alarms will be triggered. The system will call upon remaining pumps if available to provide vacuum. Similarly, the motor protector circuit breaker will de-energize the motor if its limits are exceeded and alarms will be triggered. Alarm history is stored in the PLC and can be accessed through the touch screen display. A push button near the touch screen is provided to acknowledge or silence the local alarms while investigating the source. Once the alarm conditions have been corrected the alarm may be cleared using the touch screen. If the motor protector circuit breaker tripped, the knob on the control panel must be reset to the on position.

The control panel has selector switches with Hand Off Auto positions for each pump. In normal use the switches should be placed in Auto. Hand will override the PLC control signals and cause the pump to run continuously. If both pumps are placed in hand or if one is in Hand and other is called upon, the reserve in use alarm will

activate. The pumps and motors will not be damaged when operated in Hand mode. The high temperature shut down and motor overload conditions will override the Hand selection.

The display has screens with navigation buttons. Pump running hours are tracked and may be displayed when desired. The control also has communication features using Bacnet that are described in the separate control manual.

The control panel has dual control transformers with a relay to switch to the backup if the primary should fail to provide the required control power. A local reserve in use alarm is triggered in activated.

VFD Control for Medical Vacuum Systems

The Powerex Variable Frequency Drive control system is provided with a VFD that is automatically engaged to operate the lead pump. When system demand for vacuum is low, the VFD will reduce the operating speed of the lead pump by as much as 50% to reduce flow and save energy.

VFD control systems use 60 minute alternation timing and 10 minute minimum run times.

The operating set points of the VFD control system may be adjusted using the touch screen.

⚠ WARNING Shock hazard, mechanical injury hazard. Systems with VFD controls have more than one source of power to the pump motors. When performing service Lock out and tag out the VFD motor protector circuit breaker as well as the branch motor protector circuit breaker.

Laboratory System Controls –Sequence of Operation

Powerex Laboratory Vacuum systems utilize control systems that are very similar to the Medical control systems except that the lag pump is available for normal use and no alarms are triggered if it is called upon.

The alternation timer uses a 24 hour cycle. In a system with irregular use during the day, once a pump is warm, it will be called on regularly, minimizing the tendency of any pumped gases to condense in the pump. Minimum run time is 10 minutes.

(A diagnostic override for the 24 hour timer is available for use during troubleshooting – see the wiring diagram)

PXMI

General

The Enclosed Vacuum System is controlled by a (Programmable Logic Controller) PLC. The operating status is displayed on the 6" color touch screen panel on the front of the Primary unit. The integrated controls enclosure is UL508A listed and complies with NFPA 99 requirements for Level 1 vacuum. The Primary panel will also include: audible and visual alarms with an acknowledge button and an HOA switch for each pump.

The PXMI controls allow the user to view system functions, the factory set points, and navigate through the screens to get more information about the operation of the individual vacuum modules. With PBMI card, staff can receive email notifications for service alerts and system alarms, the details of which are also displayed on the built-in webpage.

Dry contacts for remote signaling include: low vacuum (Lab models), reserve pump in use (medical models), and a general fault to indicate the following: high temperature, motor overload trip, and reserve transformer in use. All dry contacts exist only in the Primary control panel. Alarms regarding the Subordinate enclosures are detected and handled by the Primary. The PBMI communication card is a Building Automation System (BAS) communication gateway with BacNet® protocol and Web server features. The BAS communication gateway can support hundreds of pre-configured, labeled, and listed individual data points and utilizes a 10/100 BaseT Operation Ethernet port connection. Web server features include email notifications in case the system is in alarm for any reason or has achieved one of its maintenance intervals and requires service. The Primary-Subordinate communications use Modbus TCP over a separate, closed ethernet network. Do not connect BacNet® to this network.

Control Panel – Display & Input

The Powerex Medical or Laboratory Vacuum System has a HMI panel on the front of the Primary Unit to allow operation and monitoring of the unit. Once the unit is turned on, the main screen should appear (see example below). From the main screen, the light blue buttons allow the user to navigate to various other screens for important information. The main screen also displays various important information as a summary of system status.

Main

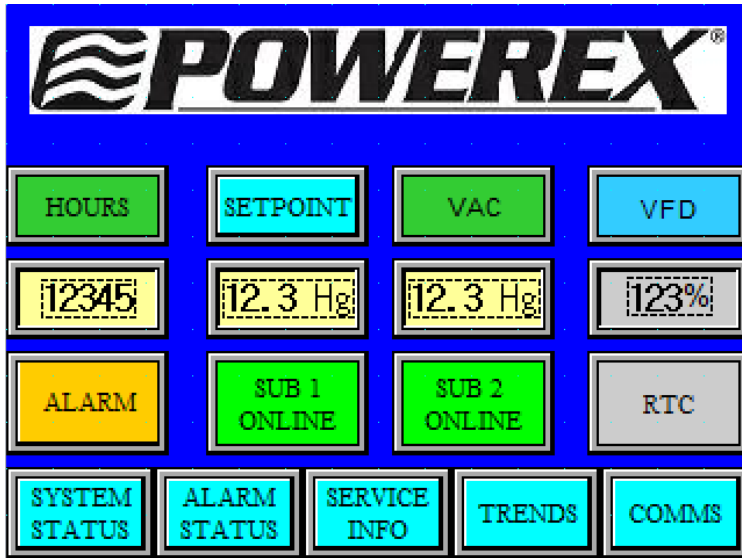

- Displays vacuum level, total system hours, lead setpoint, and VFD* status.
- VFD* and vacuum level nameplates change color depending on appropriate values.
- Light blue buttons navigate to their respective screens.
- * VFD not available on all models

System Status

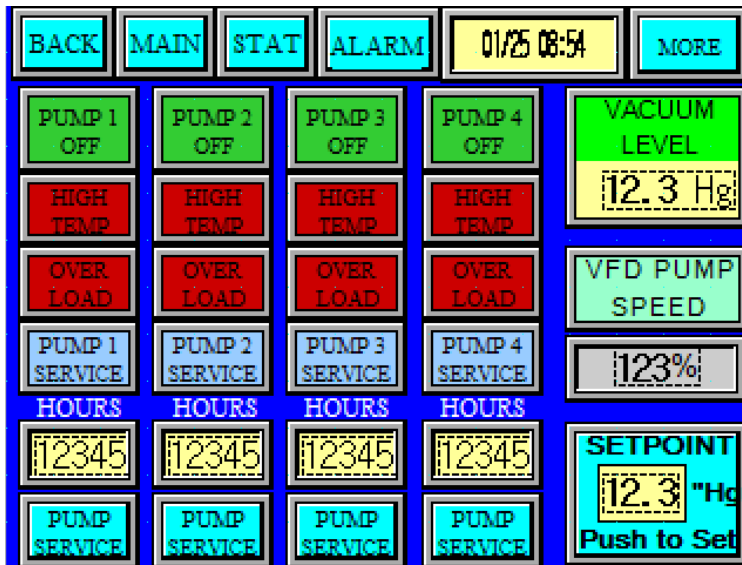

- Displays operating status, run hours, alarms, and service alert status of each pump on the system. For systems with more than 4 pumps, “More” button navigates to additional system status screen.
- Displays vacuum level of system like on MAIN page.

User Adjustable Setpoints

Adjust "Cut-in" set points only. "Cut-outs" will be calculate based on differential input. To adjust press cut-in or diff #-display's and enter value in "Hg."

"Default Setpoints" will reset all to factory default set-points.

For high elevations press #-display on far left and enter the elevation in feet/1000.

When adjustments are complete press "LOAD/ADJ CHANGES" then press back arrow button

	LEAD	CUT IN	DIFF
LAG-1	12.3	12.3	1.2
LAG-2	12.3	12.3	1.2
RES	12.3	12.3	1.2

1.2 DEFAULT SETPOINTS LOAD/ADJ CHANGES

BACK MAIN STAT ALARM

Alarm Log

BACK MAIN STAT ALARM

Occurrence

01/25 09:05

01/25 09:05

01/25 09:05

01/25 09:05

01/25 09:05

01/25 09:05

01/25 09:05

Select Scroll Up Scroll Dwn

- Record of all alarms, warnings and service alerts with date and time.

Alarm Status

BACK MAIN STAT 12.3 Hg ALARM LOG

LOW VAC RES PUMP AIR TEMP VFD ACKN

VIEW

RESV XFMR OVER LOAD PUMP MAINT COMM RESET

VIEW VIEW VIEW

- Displays alarms and service alerts
- Acknowledge and reset alarms
- Displays Vacuum Level

Service

MAIN For service call POWEREX @ 888-769-7979

SYSTEM MODEL # ABCDEFGHIJKLMNOP

SYSTEM SERIAL # 1234567

FACTORY SETTINGS PLEX MODE SEQUENCE OF OPERATION

123 FOR EXP PRESS DISP ENTER # OF PUMPS HIT LOAD SET TIME, DATE

LOAD ADJUST SCREEN CONTRAST

SYSTEM SETUP I/O CHECK

PASSWORD PROTECTED

- Displays model number, serial number, service phone number
- If system is expandable, use Plex Mode Input to adjust PLC Program to additional pumps.

To Set Time & Date

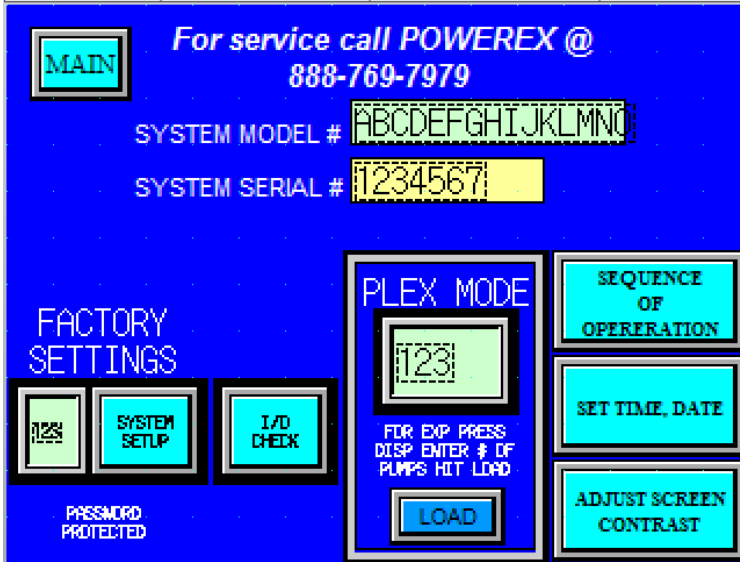

This Screen Will Appear



This Screen Will Appear

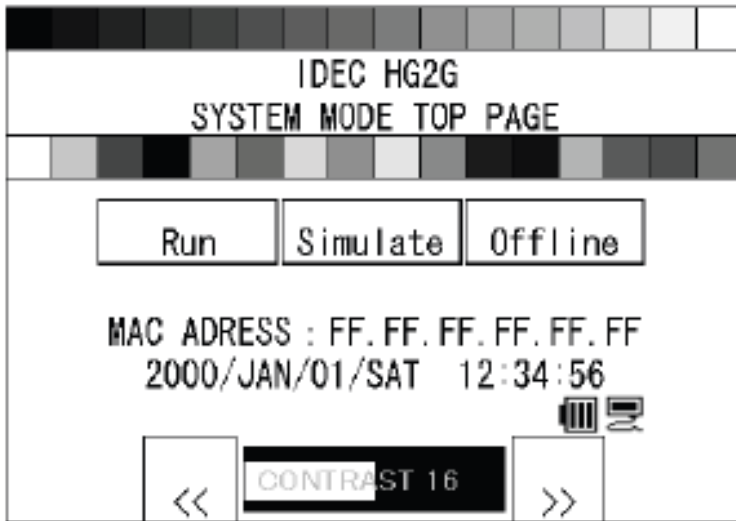

To Return to Run Mode



This Screen Will Appear

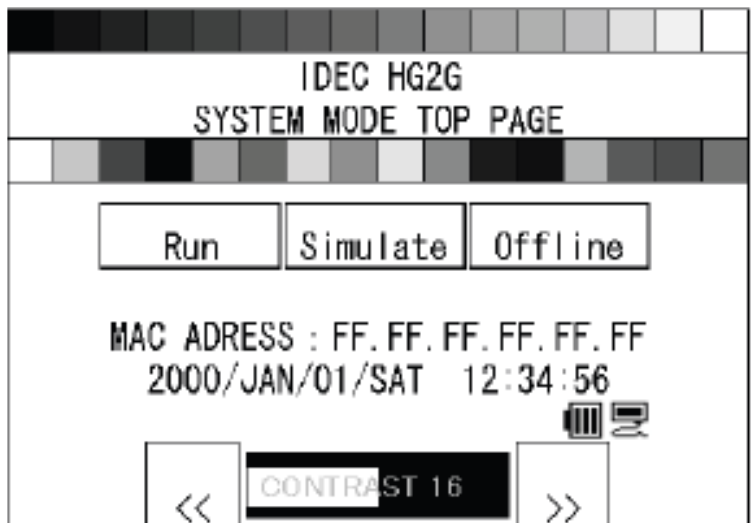

Sequence of Operation

During normal operation the PBMI controller will signal the Lead compressor to run when pressure drops below lead cut-in set point and stop when the pressure reaches the lead cut-out set point. Lead alternation to the next pump, will occur with each lead run signal or every 10-minutes (which ever happens first). If demand cannot be satisfied by the lead pump, the lag pump(s) will start and stop based upon the lag cut-in and cut-out set-points and lead alternation will occur when the lowest cut-out set-point is satisfied, or 10-minutes (which ever happens first).

The RPUI (Reserve Pump In Use) alarm, H-Temp (High Discharge Air Temp) alarm, Motor Overload trip alarm, Reserve Transformer in use and Pump Service Required warnings will cause the touch screen to default to the Alarm Status Screen. Any and all alarms must be "Acknowledged" before navigating to other screens. The Pump Status Screen will indicate which pumps are running, any alarms, warnings and hour

Pump Maintenance

The screenshot shows a blue background with white text. At the top, it says "PUMP #1 MAINT SCHEDULED" and "SEE MANUAL FOR MONTHLY MAINT ITEMS". There is a "BACK" button on the left and a numeric keypad showing "12345" on the right. Below this, a large white box contains the text "NO MAINT REQUIRED". At the bottom, there are two buttons: "ACKNOWLEDGE PM NOTIFICATION" and "CLEAR PM NOTIFICATION". Below these buttons, there is a note: "TO RESET MAINT ETM TOUCH NUM DISPLAY, KEY IN UNIT SERIAL #, HIT ENTER. PRESS RESET BUTTON." and a "RESET" button next to a numeric keypad showing "1234567".

Trend Screens

This screenshot is identical to the Pump Maintenance screen above, showing the same layout of buttons, text, and numeric keypad.

- At specific preset hour intervals, pump maintenance instructions will be displayed; this is specific to each pump.

Advanced Service Screen

The screenshot shows a blue background with white text. At the top, it says "ADVANCED SERVICE FEATURES". There is a "BACK" button on the left. Below this, there is a note: "MOTOR WILL RUN FOR 1 SECOND. 15 SECOND DELAY AFTER MOTOR JOG." To the right of this note are two buttons: "MRT SERVICE OVERRIDE" and "TEST SERVICE ALERT CONTACT". Below these are two rows of buttons. The first row contains "JOG PUMP 1", "JOG PUMP 3", "JOG PUMP 5", and "TEST GENERAL FAULT CONTACT". The second row contains "JOG PUMP 2", "JOG PUMP 4", "JOG PUMP 6", and "TEST RESERVE PUMP CONTACT".

- Jog individual pumps and test service alert contacts.
- Navigate to service override screen.

MRT Override Screen

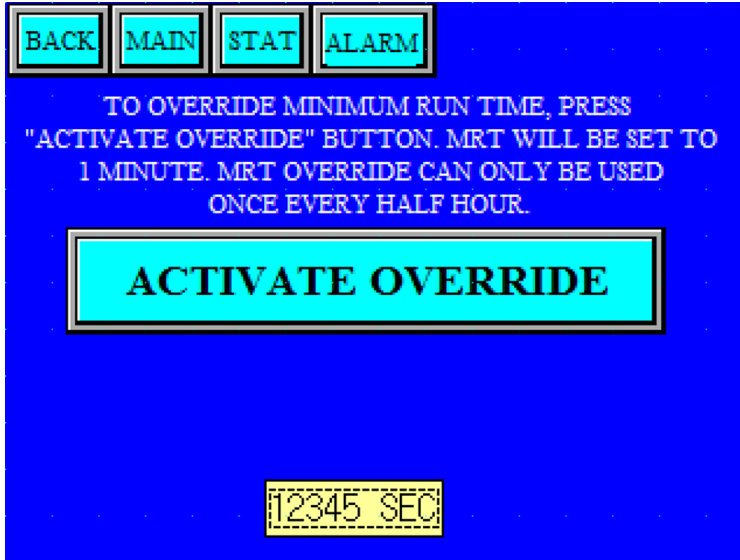

- Changes pump minimum run time to 1 minute.

Runtime Control System

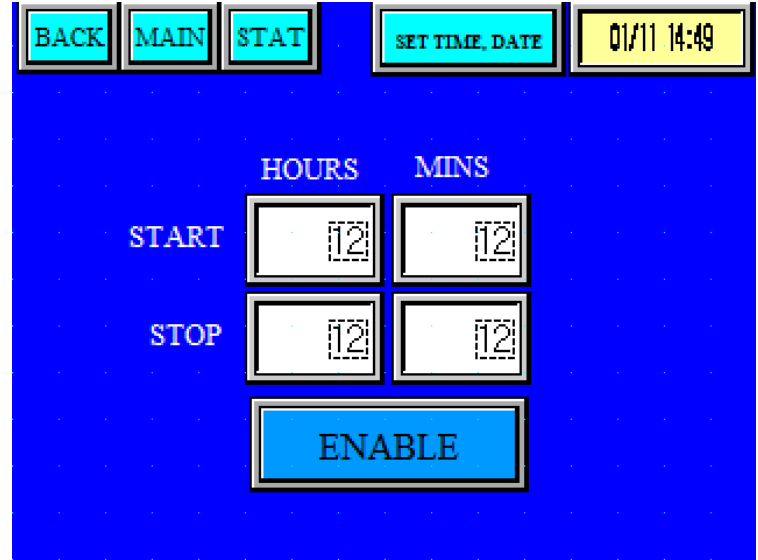

- Used to stop system from running at night if desired.
- Lab only feature.

Subordinate Identify Screen

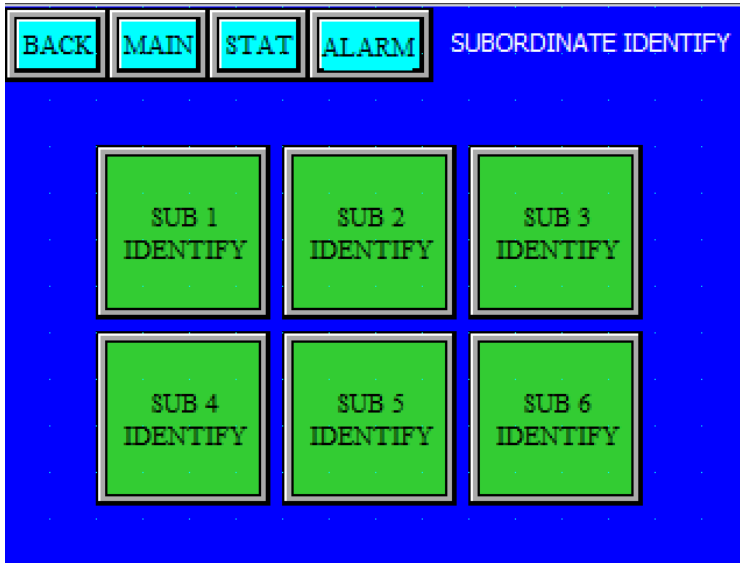

- When "Identify" button is pressed on each subordinate. This screen pops up with a flashing

Diagnostics Screen

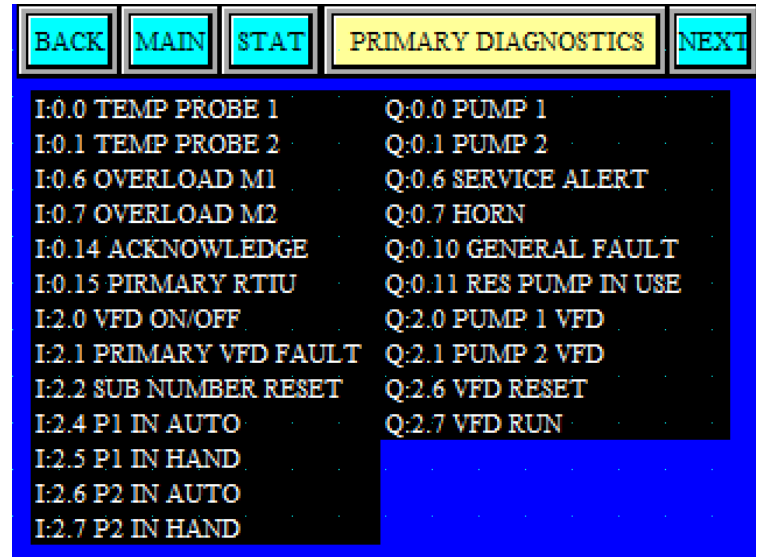

- Displays current state of inputs and outputs for each control panel.

Maintenance Lubrication

Refer to the manual from the vacuum pump manufacturer for lubrication intervals and type of oil to use. Oilless claw vacuum pumps have gear boxes that must be maintained and the gearbox oil needs to be changed at specified intervals.

NOTICE If the gas being pumped through the vacuum system is known to be incompatible with petroleum based oils, the user must drain and refill the vacuum pumps with suitable oil before use. Failure to do so will void the warranty.

⚠ WARNING

RISK OF ELECTRIC SHOCK AND INJURY

Multiple supply sources. Always disconnect VFD and motor circuit before servicing.

Multiple pump Vacuum System controls with Variable Frequency Drive have multiple sources of supply for the electric power. To eliminate the risk of electric shock and injury while performing service on any of the pump-motors, always disconnect, lock out and tag out the main motor circuit and the VFD supply circuit. Failure to disconnect and secure both circuits could allow the pump motor to start during the service activity and may lead to electric shock and injury.

Maintenance Schedule

Item	Action Needed	Operating Hours							Remarks
		500	2500	3000	5000	10000	15000	20000	
Inlet air filter	Inspect, Replace	●	▲	●					Every 3,000 hours or less
Blower fan	Clean				●	●	●	●	
Fan shield	Clean				●	●	●	●	
Pump fans	Clean				●	●	●	●	
Vacuum switch	Inspect				●	●	●	●	
Gear oil	Inspect, Replace			●				▲	Every 3,000 hours or less

- Inspect
- ▲ Replace

- NOTES:**
- Inspect and perform maintenance periodically according to maintenance schedule.
 - The maintenance schedule relates to the normal operating conditions. If the circumstances and load condition are adverse, shorten the interval time and perform maintenance accordingly.

Troubleshooting Guide

Problem	Cause	Corrective Action
Lag Alarm	Overload Tripped	<ol style="list-style-type: none"> Reset overload; if problem continues, check motor amp draw Verify overload is set to the correct service factor Verify wire gauge is correct for amp draw
	PLC Failure	<ol style="list-style-type: none"> Check PLC for red error light; replace PLC Check PLC for flashing green light; if 24V DC is present on the last input, then reprogram PLC with E-Prom chip
	Pump / Motor Failure	<ol style="list-style-type: none"> Check drive coupling; replace if needed Verify that pump shaft turns freely; repair or replace as necessary Check vacuum discharge piping to verify air is being exhausted; repair or replace as necessary Verify voltage to the motor; repair wiring or replace motor as necessary
	Vacuum Consumption	<ol style="list-style-type: none"> Repair leaks Inspect purge valves are closing; repair or replace as necessary
	Switch Failure	Check continuity on lead vacuum switch
High Temperature Alarm	High Temperature	Verify ambient temperature is below 104 ° F
	Lost Connection	Inspect high temperature probe and connections; replace if necessary

Troubleshooting Guide

Problem	Cause	Corrective Action
Lag Alarm	Overload Tripped	1. Reset overload; if problem continues, check motor amp draw and supply voltage 2. Verify overload is set to the correct setting including 1.15 service factor 3. Verify wire gauge is correct for amp draw
	PLC Failure	1. Check PLC for red error light; replace PLC 2. Check PLC for flashing green light; if 24V DC is present on the last input, then reprogram PLC with E-Prom chip 3. Call Powerex Technical Service
	Pump/Motor Failure	1. Check drive coupling; replace if needed 2. Verify that pump shaft turns freely; repair or replace as necessary 3. Check vacuum discharge piping to verify air is being exhausted; repair or replace as necessary 4. Verify voltage to the motor; repair wiring or replace motor as necessary 5. Check contactor for burnt/corroded contacts, and replace if necessary
	Vacuum Consumption	1. Repair leaks, check for open valves 2. Inspect purge valves are closing; repair or replace as necessary
	Transducer Failure	Check HMI display for vacuum level
High Temperature Alarm	High Temperature	Verify ambient temperature is below 104°F
	Lost Connection	Inspect high temperature probe and connections; replace if necessary
	Cooling Fans	Verify both enclosure and exhaust fans operate when the pump runs. If not, check fan motor overload and fan motor.

Powerex Limited Warranty – Applicable to Non-OEM Customers in the U.S. & Canada Only

Warranty and Remedies.

(a) General. Powerex warrants each Compressor System, Vacuum System, Vacuum Pump, Compressor Air-End, or Powerex branded Accessory (collectively “Products”, individually each a “Product”) to be free from defects in material and workmanship (“Defects”) at the date of shipment. This warranty shall apply only to Products that are purchased and used in the United States of America and in Canada. EXCEPT AS SET FORTH BELOW, NO OTHER WARRANTY, WHETHER EXPRESS OR IMPLIED, INCLUDING ANY WARRANTY OF MERCHANTABILITY OR FITNESS FOR A PARTICULAR PURPOSE, SHALL EXIST IN CONNECTION WITH THE SALE OR USE OF SUCH PRODUCTS. TO THE EXTENT PERMITTED BY LAW, ANY AND ALL IMPLIED WARRANTIES ARE EXCLUDED. All warranty claims must be made in writing and delivered to Powerex in accordance with the procedures set forth on its website (www.powerexinc.com), or such claim shall be barred. Upon timely receipt of a warranty claim, Powerex shall inspect the Product claimed to have a Defect, and Powerex shall repair, or, at its option, replace, free of charge, any Product which it determines to have had a Defect; provided, however, that if circumstances are such as to preclude the remedying of Defect by repair or replacement, Powerex shall, upon return of the Product, refund to buyer any part of the purchase price of such Products paid to Powerex. Freight for returning Products to Powerex for inspection shall be paid by buyer. The warranties and remedies herein are the sole and exclusive remedy for any breach of warranty or for any other claim based on any Defect, or non-performance of the Products, whether based upon contract, warranty or negligence.

(b) (i) Standard Period of Warranty – Parts and Labor. The purchase of any system includes our standard warranty. Powerex warrants and represents all Products shall be free from Defects for the first eighteen (18) months from the date of shipment by Powerex, or twelve (12) months from the documented date of startup, or five thousand (5,000) hours of use, whichever occurs first. During such warranty period, Powerex shall be fully liable for all Defects in the Products (the “Product Defects”), i.e., all costs of repair or replacement, which may include “in and out” charges, so long as the Products are located in the United States or Canada, and the Products are reasonably located and accessible by service personnel for removal. “In and out” charges include the costs of removing a Product from buyer’s equipment for repair or replacement.

(ii) Premium Period of Warranty – Parts and Labor. In order to be eligible for premium warranty coverage, a premium warranty for each system must be purchased when order is placed. Powerex warrants and represents all Products shall be free from Defects for the first thirty (30) months from the date of shipment by Powerex, or twenty-four (24) months from the documented date of startup, or seven thousand five hundred (7,500) hours of use, whichever occurs first. During such warranty period, Powerex shall be fully liable for all Defects in the Products (the “Product Defects”), i.e., all costs of repair or replacement, which may include “in and out” charges, so long as the Products are located in the United States or Canada, and the Products are reasonably located and accessible by service personnel for removal. “In and out” charges include the costs of removing a Product from buyer’s equipment for repair or replacement.

(c) Additional Period of Warranty – Parts Only (No Labor). In addition to the above, Powerex warrants each Powerex branded Compressor Air- End and Vacuum Pump shall be free of Defects for a period of forty-two (42) months from the date of shipment by Powerex, or thirty-six (36) months from the documented date of startup, or ten thousand (10,000) hours of use, whichever occurs first. Supplier’s repair or replacement of any Product shall not extend the period of any warranty of any Product. This warranty applies to the exchange of part(s) found to be defective by an Authorized Powerex Service Representative only.

(d) Replacement Pumps – Parts Only (No Labor). For any replacement Air-End or Vacuum Pumps installed on a Powerex manufactured system or unit after any initial warranty period has expired or where another warranty does not apply for any reason, Powerex warrants that the Air-End or Vacuum Pumps shall be free of Defects for a period of thirty-six (36) months from the date of shipment by Powerex or ten thousand (10,000) hours of use, whichever comes first. For any replacement Air-End or Vacuum Pumps installed on a system that was not manufactured by Powerex after any initial warranty period has expired or where another warranty does not apply for any reason, Powerex warrants that the Air-End or Vacuum Pumps shall be free of Defects for the first twelve (12) months from the date of shipment by Powerex. Supplier’s repair or replacement of any Product shall not extend the period of any warranty of any Product. This warranty applies to the exchange of part(s) found to be defective by an Authorized Powerex Service Representative only.

(e) Replacement Motors – Parts Only (No Labor). For any replacement motor installed on a Powerex manufactured system or unit after any initial warranty period has expired or where another warranty does not apply for any reason, Powerex warrants that the replacement motor shall be free of Defects for the first twelve (12) months from the date of shipment by Powerex. For any replacement motor installed on a system or unit that was not manufactured by Powerex after any initial warranty period has expired or where another warranty does not apply for any reason, Powerex warrants that the replacement motor shall be free of Defects for the first ninety (90) days from the date of shipment by Powerex. Supplier’s repair or replacement of any Product shall not extend the period of any warranty of any Product. This warranty applies to the exchange of part(s) found to be defective by

an Authorized Powerex Service Representative only.

(f) Replacement Parts – Parts Only (No Labor). For other replacement parts besides motors, Air-End or Vacuum Pumps installed on a Powerex manufactured system or unit after any initial warranty period has expired or where another warranty does not apply for any reason, Powerex warrants that such replacement parts will be free from Defects for the first twelve (12) months from the date of shipment by Powerex. For other replacement parts besides motors, Air-End or Vacuum Pumps installed on a system or unit that was not manufactured by Powerex after any initial warranty period has expired or where another warranty does not apply for any reason, Powerex warrants that such replacement parts will be free from Defects for the first twelve (12) months from the date of shipment by Powerex. For other replacement parts besides motors, Air-End or Vacuum Pumps installed on a system or unit that was not manufactured by Powerex after any initial warranty period has expired or where another warranty does not apply for any reason, Powerex makes no warranties. Supplier's repair or replacement of any Product shall not extend the period of any warranty of any Product. This warranty applies to the exchange of part(s) found to be defective by an Authorized Powerex Service Representative only.

(g) Coverage. The warranty provided herein applies to Powerex manufactured units or systems only.

(h) Exceptions. Notwithstanding anything to the contrary herein, Powerex shall have no warranty obligations with respect to Products:

- (i)** That have not been installed in accordance with Powerex's written specifications and instructions;
- (ii)** That have not been maintained in accordance with Powerex's written instructions;
- (iii)** That have been materially modified without the prior written approval of Powerex; or
- (iv)** That experience failures resulting from operation, either intentional or otherwise, in excess of rated capacities or in an otherwise improper manner.

The warranty provided herein shall not apply to: **(i)** any defects arising from corrosion, abrasion, use of insoluble lubricants, or negligent attendance to or faulty operation of the Products; **(ii)** ordinary wear and tear of the Products; or **(iii)** defects arising from abnormal conditions of temperature, dirt or corrosive matter; **(iv)** any OEM component which is shipped by Powerex with the original manufacturer's warranty, which shall be the sole applicable warranty for such component.

Limitation of Liability. NOTWITHSTANDING ANYTHING TO THE CONTRARY HEREIN, TO THE EXTENT ALLOWABLE UNDER APPLICABLE LAW, UNDER NO CIRCUMSTANCES SHALL POWEREX BE LIABLE FOR ANY INCIDENTAL, CONSEQUENTIAL, PUNITIVE, SPECULATIVE OR INDIRECT LOSSES OR DAMAGES WHATSOEVER ARISING OUT OF OR IN ANY WAY RELATED TO ANY OF THE PRODUCTS OR GOODS SOLD OR AGREED TO BE SOLD BY POWEREX TO BUYER. TO THE EXTENT ALLOWABLE UNDER APPLICABLE LAW, POWEREX'S LIABILITY IN ALL EVENTS IS LIMITED TO, AND SHALL NOT EXCEED, THE PURCHASE PRICE PAID.

Warranty Disclaimer. Powerex has made a diligent effort to illustrate and describe the Products in its literature, including its Price Book, accurately; however, such illustrations and descriptions are for the sole purpose of identification, and do not express or imply a warranty that the Products are merchantable, or fit for a particular purpose, or that the Products will necessarily conform to the illustrations or descriptions.

Product Suitability. Many jurisdictions have codes and regulations governing sales, construction, installation, and/or use of Products for certain purposes, which may vary from those in neighboring areas. While Powerex attempts to assure that its Products comply with such codes, it cannot guarantee compliance, and cannot be responsible for how the product is installed or used. Before purchase and use of a Product, please review the Product applications, and national and local codes and regulations, and be sure that the Product, installation, and use will comply with them.

Claims. Any non-warranty claims pertaining to the Products must be filed with Powerex within 6 months of the invoice date, or they will not be honored. Prices, discounts, and terms are subject to change without notice or as stipulated in specific Product quotations. Powerex shall not be liable for any delay or failure arising out of acts of the public enemy, fire, flood, or any disaster, labor trouble, riot or disorder, delay in the supply of materials or any other cause, whether similar or dissimilar, beyond the control of Company. All shipments are carefully inspected and counted before leaving the factory. Please inspect carefully any receipt of Products noting any discrepancy or damage on the carrier's freight bill at the time of delivery. Discrepancies or damage which obviously occurred in transit are the carrier's responsibility and related claims should be made promptly directly to the carrier. Returned Products will not be accepted without prior written authorization by Powerex and deductions from invoices for shortage or damage claims will not be allowed. **UNLESS OTHERWISE AGREED TO IN WRITING, THE TERMS AND CONDITIONS CONTAINED IN THIS LIMITED WARRANTY WILL CONTROL IN ANY TRANSACTION WITH POWEREX.** Any different or conflicting terms as may appear on any order form now or later submitted by the buyer will not control. All orders are subject to acceptance by Powerex.