

LVECD0604xx1

LVAC ENCLOSURE 6 HP DUPLEX CLAW 120G TANK

| REVISION NOTES | | |
|-----------------------|----------|----------|
| DESCRIPTION | ECN | PR/NOR |
| RELEASE TO PRODUCTION | PXEC0481 | XXXXXXXX |

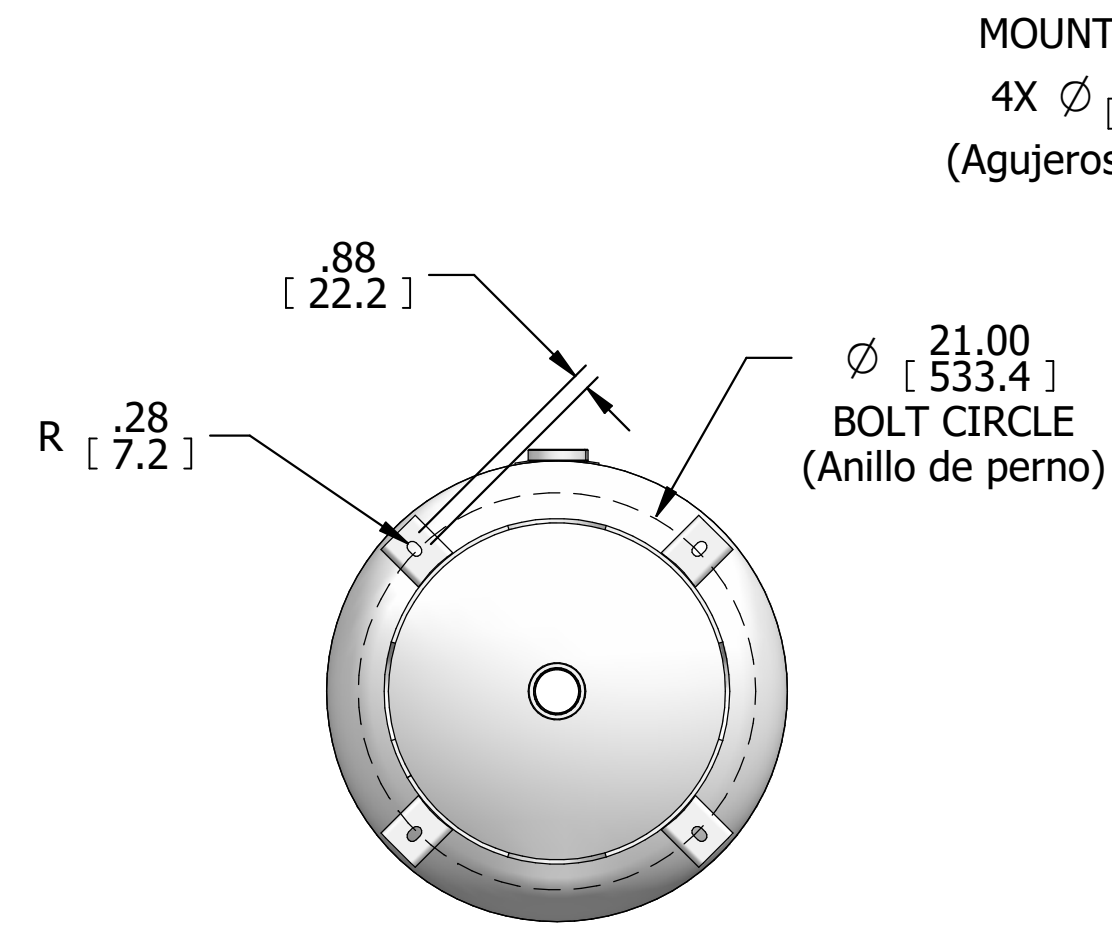

4X FLOOR MOUNTING SLOTS
(Ranuras de Montaje)

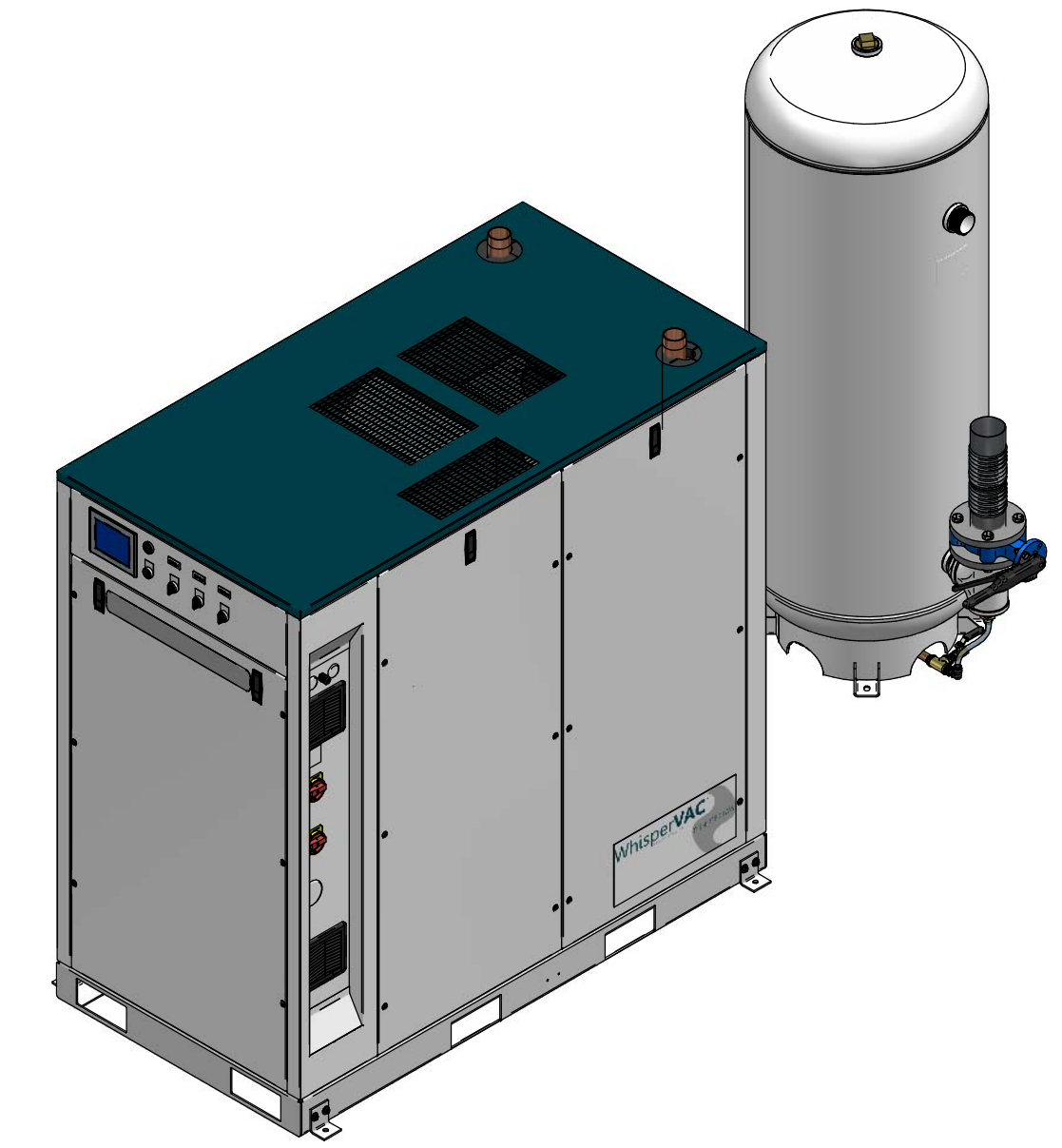
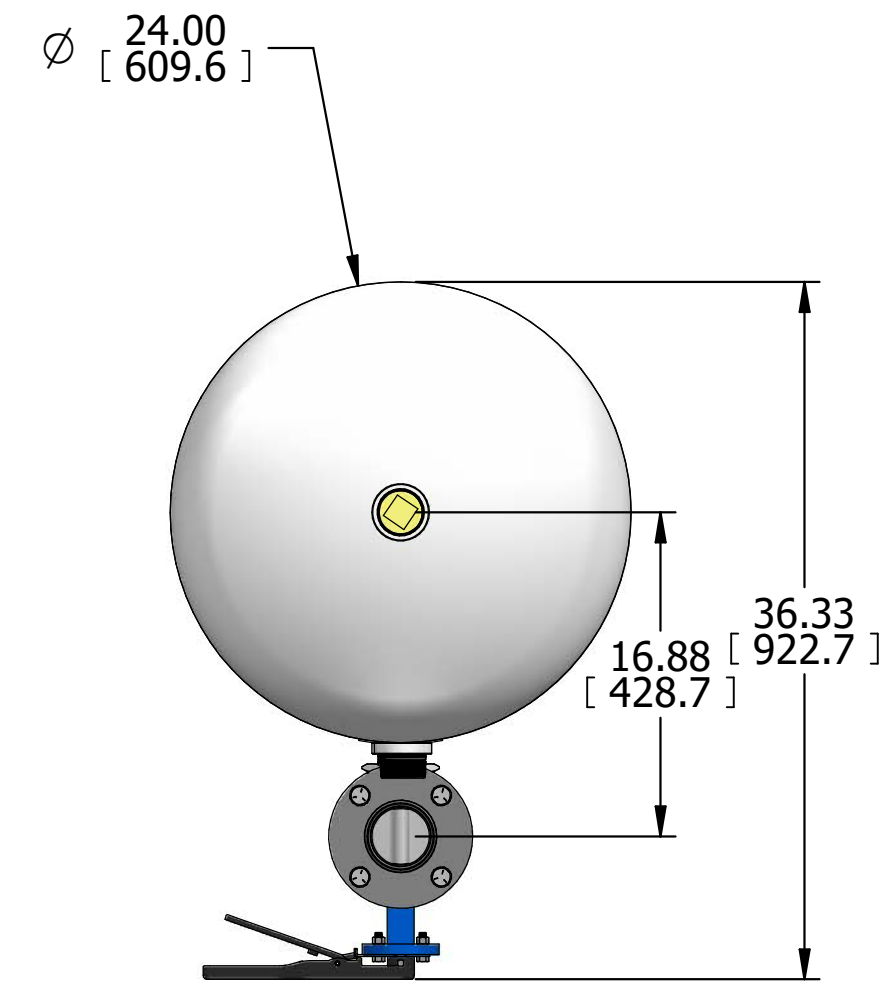
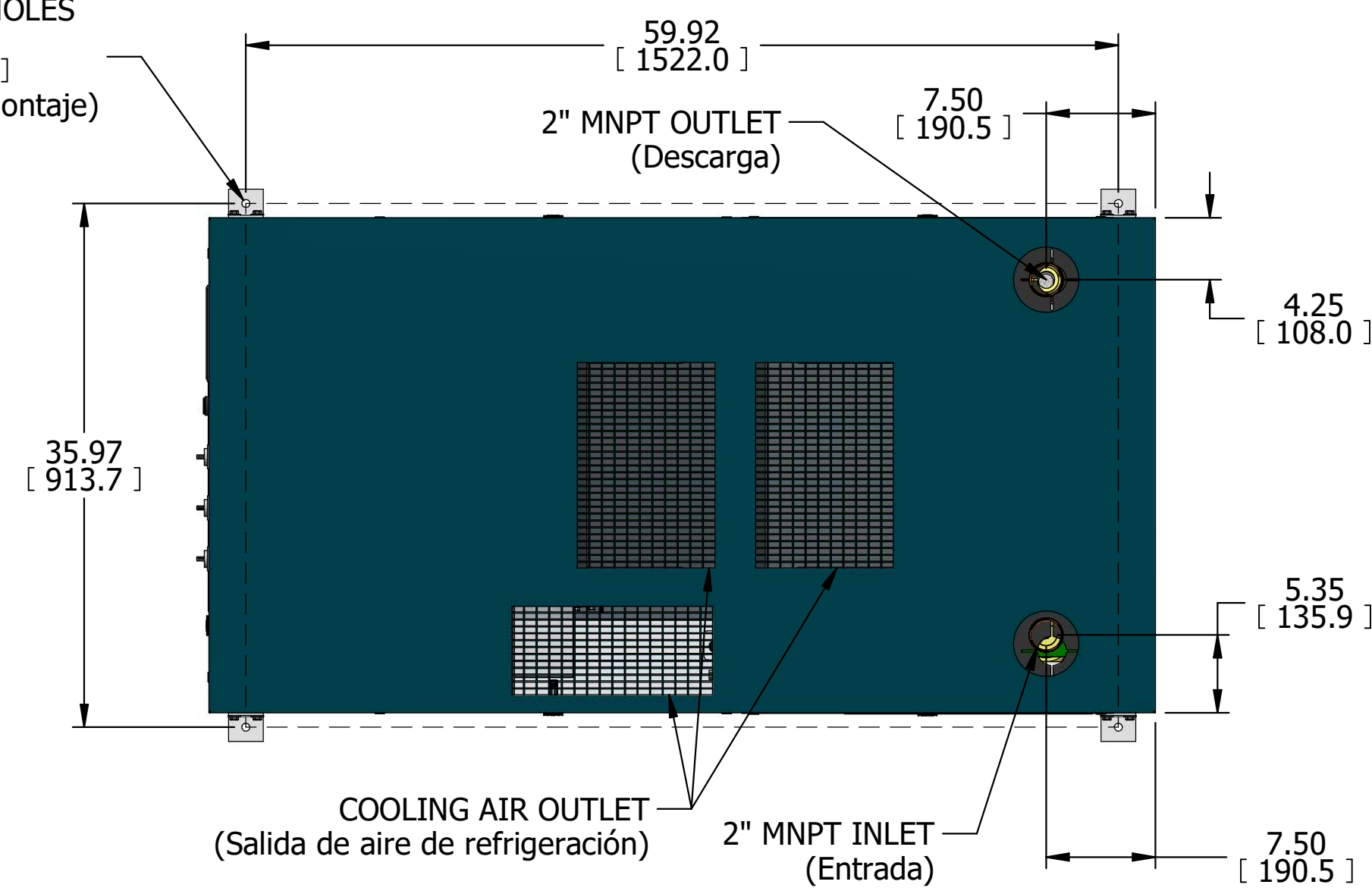

ISO VIEW

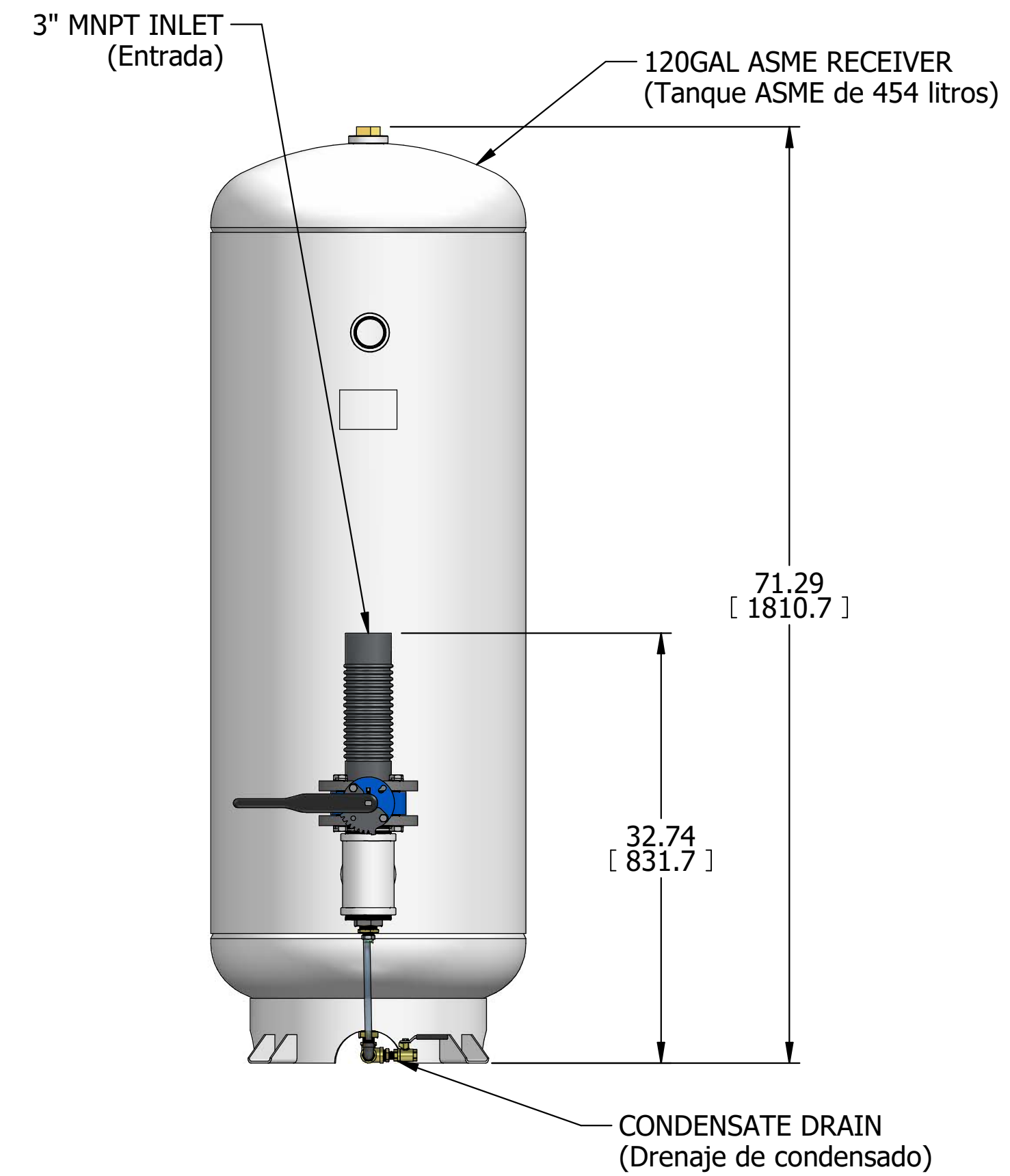
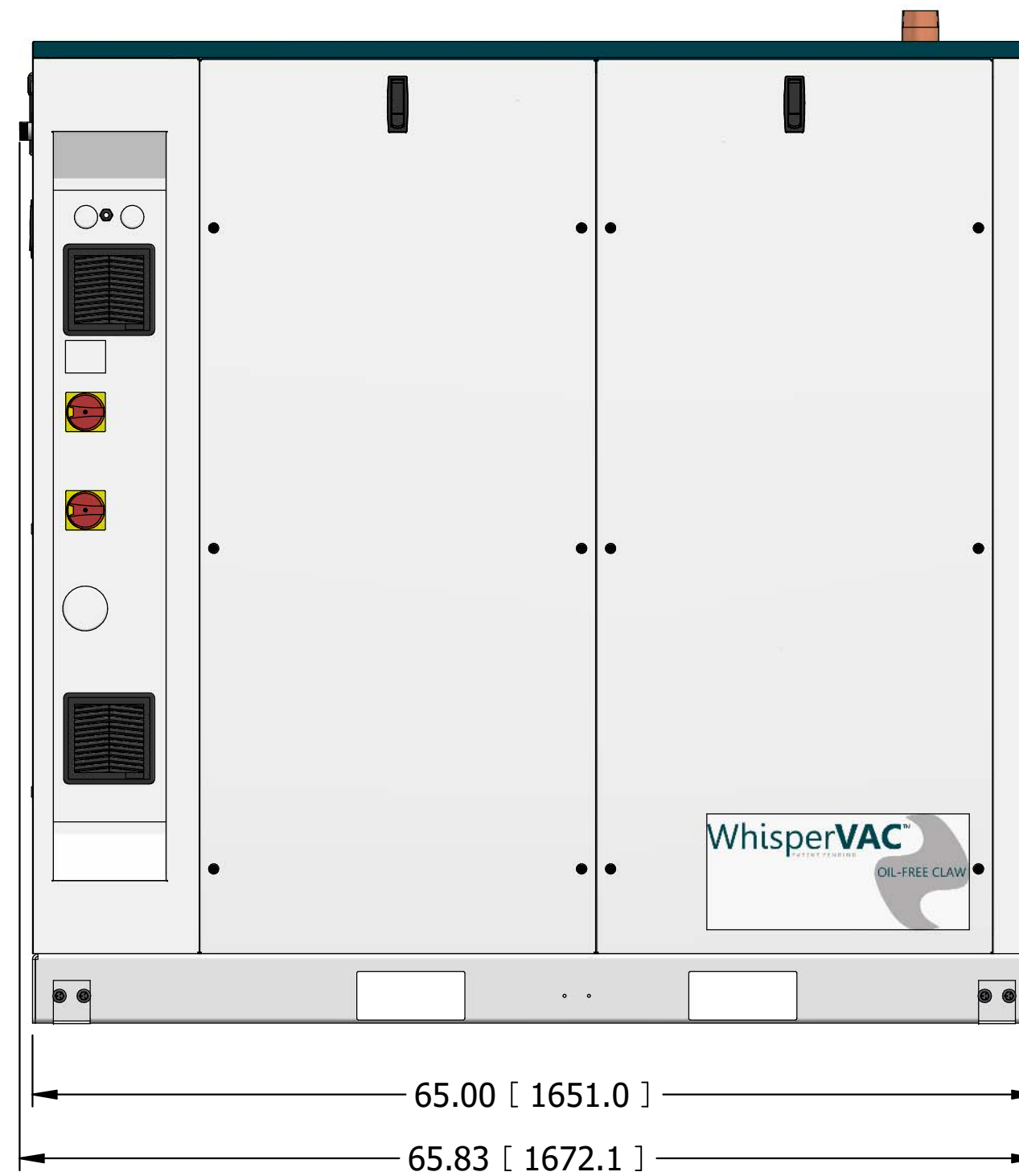
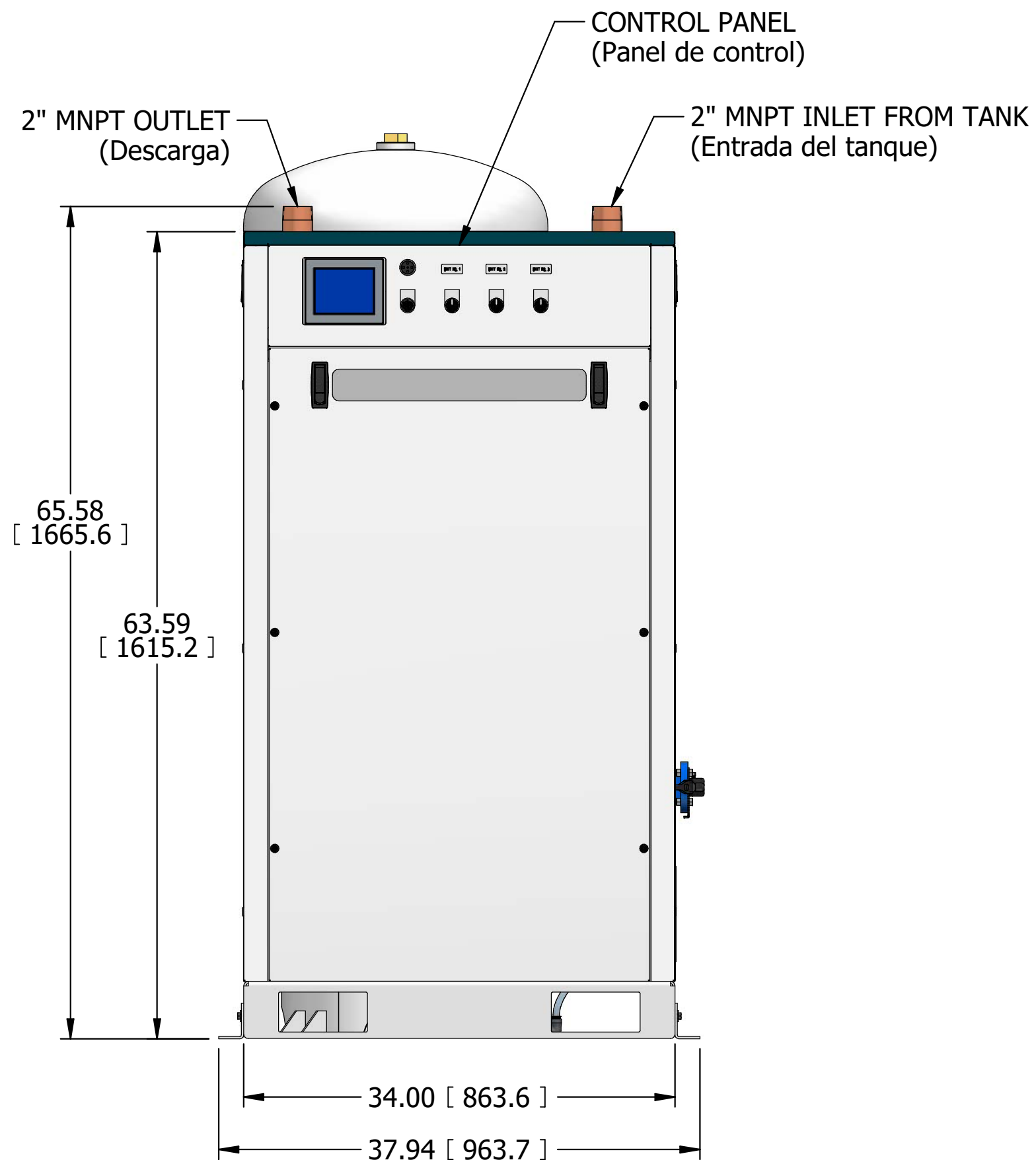

- NOTES:
- APPROXIMATE WEIGHT: 2602 LBS
 - A MINIMUM OF 24" CLEARANCE IS RECOMMENDED AROUND THE ENTIRE UNIT. CLEARANCE FOR CONTROL PANEL SHALL BE IN ACCORDANCE WITH OSHA/NEC REQUIREMENTS.
 - ALL PLUMBING FROM TANK OUTLET TO ENCLOSURE INLET(S) SHALL BE FIELD-SUPPLIED.
 - SYSTEM DESIGNED IN COMPLIANCE WITH U.S. NFPA '99, LATEST EDITION.
1. PESO APROXIMADO: 1180 kg
2. RECOMENDAMOS QUE EL ESPACIO LIBRE ALREDEDOR DEL SISTEMA DEBE SER COMO MÍNIMO 24" (600 mm). EL ESPACIO LIBRE PARA EL TABLERO DE CONTROL DEBERÁ ESTAR DE ACUERDO CON LOS REQUERIMIENTOS DE SEGURIDAD DE LA OSHA/NEC.
3. TODA LA PLOMERÍA DESDE LA DESCARGA DEL TANQUE HASTA LA(S) ENTRADA(S) DEL CERCADO DEBE SER SUMINISTRADA POR EL CLIENTE.
4. EL SISTEMA ESTÁ DISEÑADO DE ACUERDO CON LA ÚLTIMA EDICIÓN DE LA NFPA 99.

| SYMBOL LEGEND | | DRAWINGS TO CONFORM TO CURRENT REVISION OF THE FOLLOWING ANSI STANDARDS: | |
|---|--------------------|--|---------------|
| | | Y14.1 MULTI AND SECTIONAL VIEWS | |
| | | Y14.3 DIMENSIONING AND TOLERANCING | |
| TOLERANCES, UNLESS OTHERWISE SPECIFIED: | | DO NOT SCALE DRAWING FOR DIMENSIONS | |
| 0.XX ± .005 | SOLID EDGE DRAWING | | |
| 0.XXX ± .005 | | | |
| ± .1 | INCH [mm] | SHEET 1 OF 2 | SCALE 1:10 |
| CONFIDENTIAL DISCLOSURE This drawing is the property of POWEREX of the SCOTT FEZTER COMPANY and is subject to return on demand. Its contents are confidential and must not be copied or submitted to outside parties for use or examination. | | AUTHOR | REVISION DATE |
| | | aturner | 1/8/2024 |
| ITEM NO: 752310 | | APPROVALS ON FILE IN PLM | |
| MATERIAL: --- | | POWEREX | |
| | | 150 PRODUCTION DRIVE, HARRISON OH 45030 (888) 769-7979 | |
| DESCRIPTION | DRAWING NUMBER | REVISION | SIZE |
| LVAC ENCLOSURE 6 HP DUPLEX CLAW 120G TANK | LVECD0604xx1 | A | D |

POWEREX™

LVECD0604xx1

LVAC ENCLOSURE 6 HP DUPLEX CLAW 120G TANK

| REVISION NOTES | | |
|-----------------------|----------|----------|
| DESCRIPTION | ECN | PR/NOR |
| RELEASE TO PRODUCTION | PXEC0481 | XXXXXXXX |

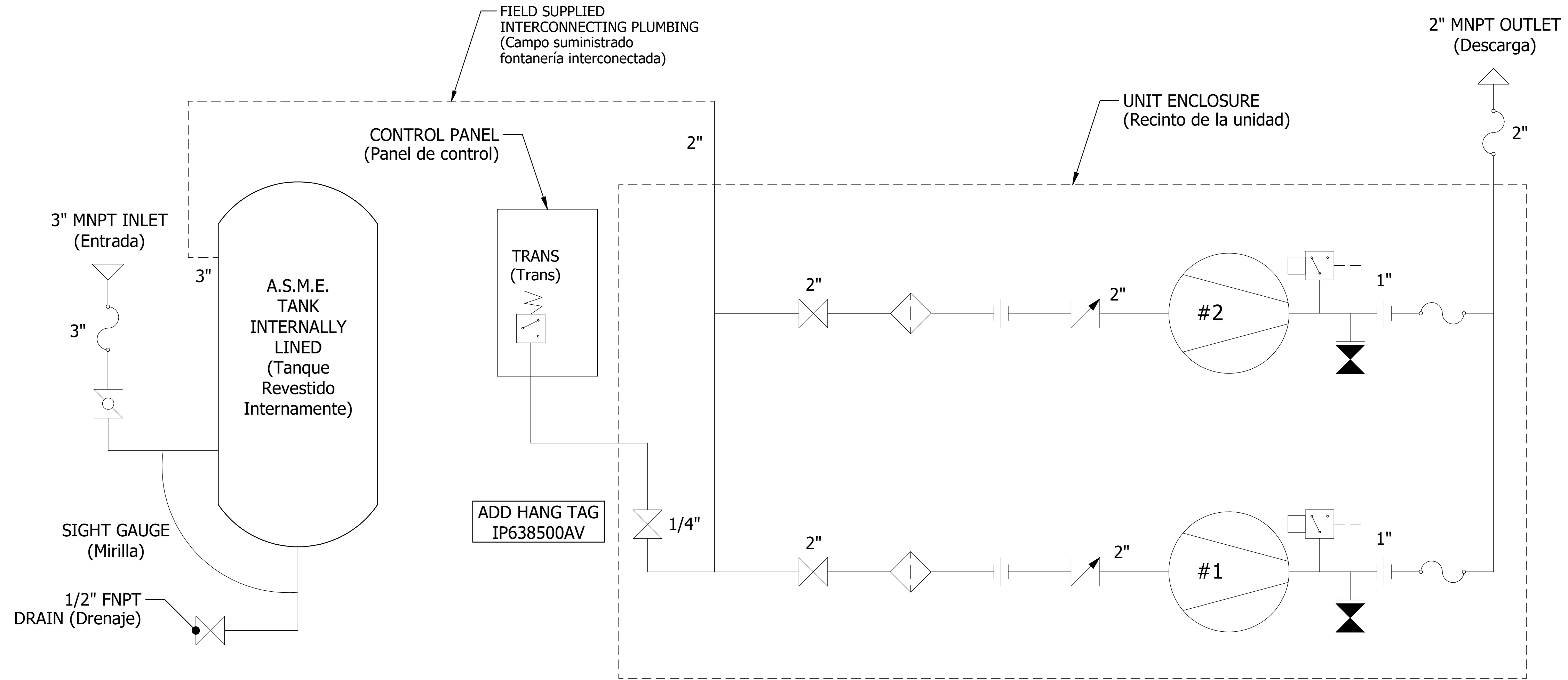

POWEREX™

LEGEND (Leyenda)

| | | | |
|--|------------------------------------|--|---|
| | CHECK VALVE (Válvula Cheque) | | VACUUM PUMP (Bomba de Succión) |
| | BALL VALVE (Válvula de Bola) | | BUTTERFLY VALVE (Válvula de Mariposa) |
| | INTAKE FILTER (Filtro admisión) | | FLEX HOSE (Manguera flexible) |
| | GAUGE (Manómetro) | | TEMPERTURE SWITCH (Interruptor temperatura) |
| | UNION (Unión) | | VACUUM SWITCH/TRANSDUCER (Interruptor/Transductor vacío) |
| | DRAIN COCK (Grifo de Drenaje) | | SOLENOID VALVE (Válvula solenoide) |
| | AIR LINE (Tubería de Aire) | | CONDENSATE LINE (Línea de Condensado) |

| | | | |
|--|-----------------------|---|--|
| SYMBOL LEGEND | | DRAWINGS TO CONFORM TO CURRENT REVISION OF THE FOLLOWING ANSI STANDARDS: | |
| | | Y14.3 MULTI AND SECTIONAL VIEW DWGS Y14.5 DIMENSIONING AND TOLERANCING | |
| TOLERANCES: UNLESS OTHERWISE SPECIFIED | | DO NOT SCALE DRAWING FOR DIMENSIONS | |
| 0.XX ± .005 | SOLID EDGE DRAWING | | |
| 0.XXX ± .005 | INCH [mm] | SHEET 2 OF 2 | SCALE 1:1 |
| ± .1 | | | |
| CONFIDENTIAL DISCLOSURE This drawing is the property of POWEREX of the SCOTT FEZTER COMPANY and is subject to return on demand. Its contents are confidential and must not be copied or submitted to outside parties for use or examination. | | AUTHOR aturner | APPROVALS ON FILE IN PLM REVISION DATE 1/8/2024 |
| ITEM NO: 752310 | | POWEREX™ | |
| MATERIAL: --- | | 150 PRODUCTION DRIVE, HARRISON OH 45030 (888) 769-7979 | |
| DESCRIPTION LVAC ENCLOSURE 6 HP DUPLEX CLAW 120G TANK | | DRAWING NUMBER LVECD0604xx1 | REVISION A SIZE D |