

LVECP1505xx1

LAB VAC ENCL 15 HP PENTAPLX CLAW 200G TANK

REVISION NOTES		
DESCRIPTION	ECN	PR/NOR
RELEASE TO PRODUCTION	PXEC0481	XXXXXXX

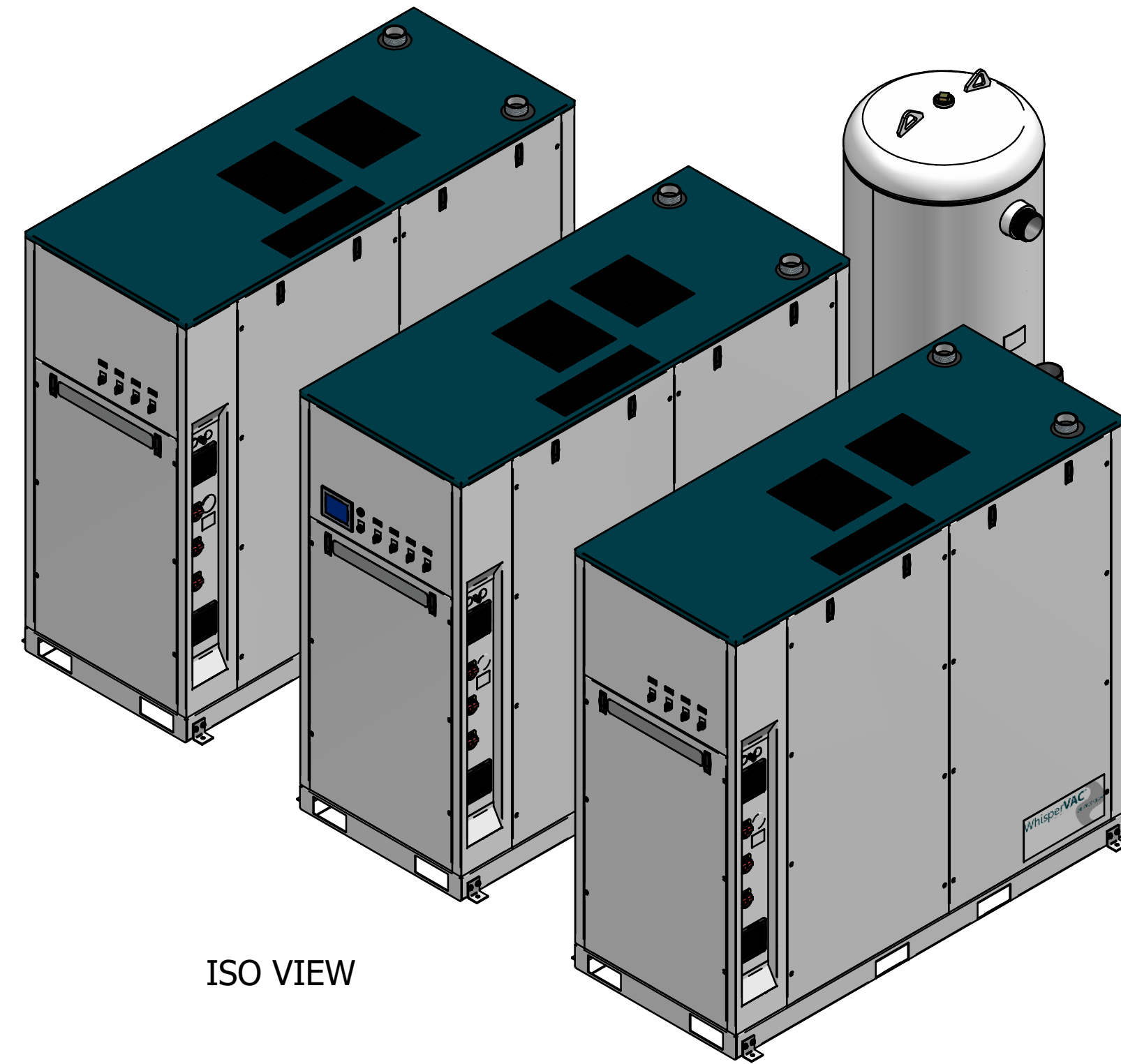

ISO VIEW

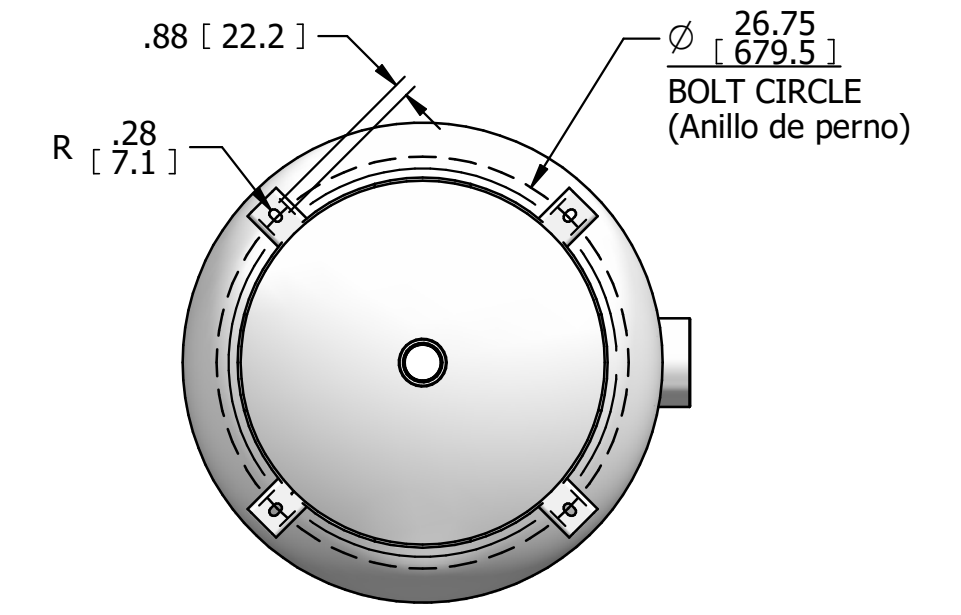
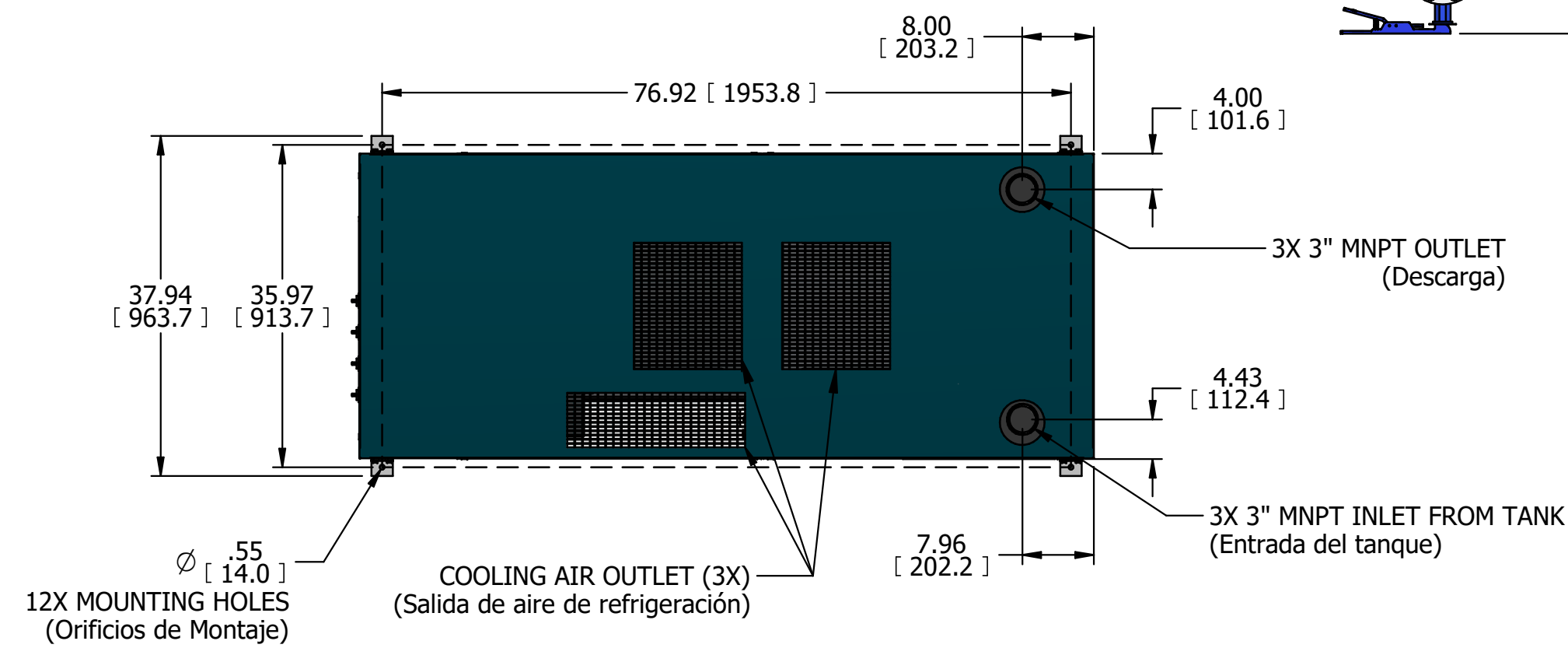
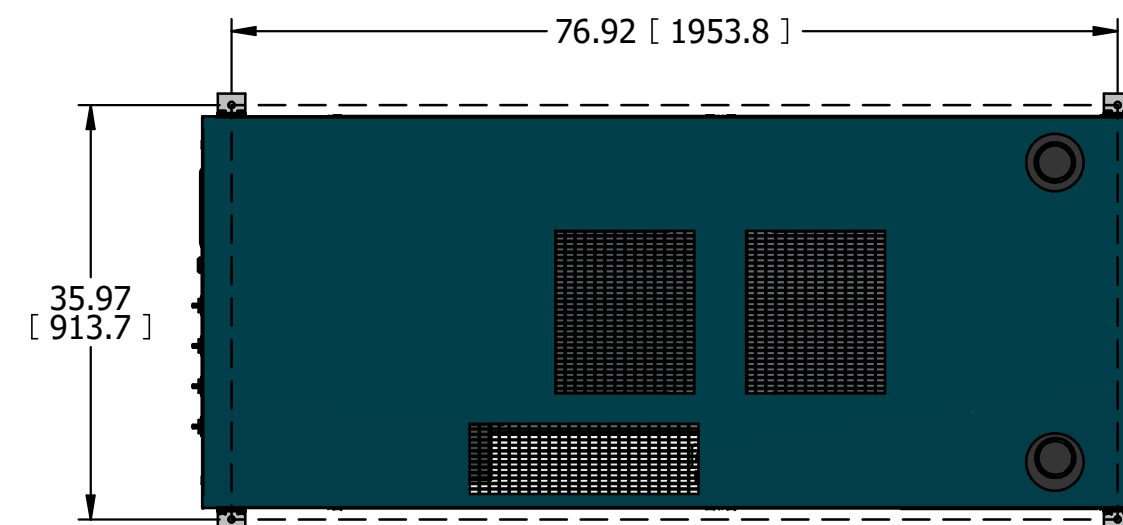
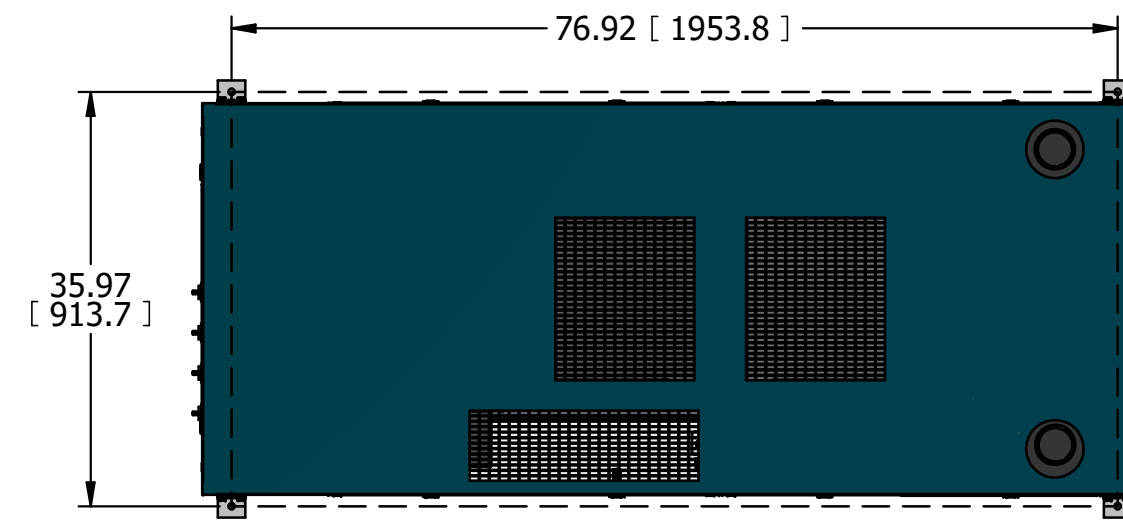

4X FLOOR MOUNTING SLOTS (Ranuras de Montaje)

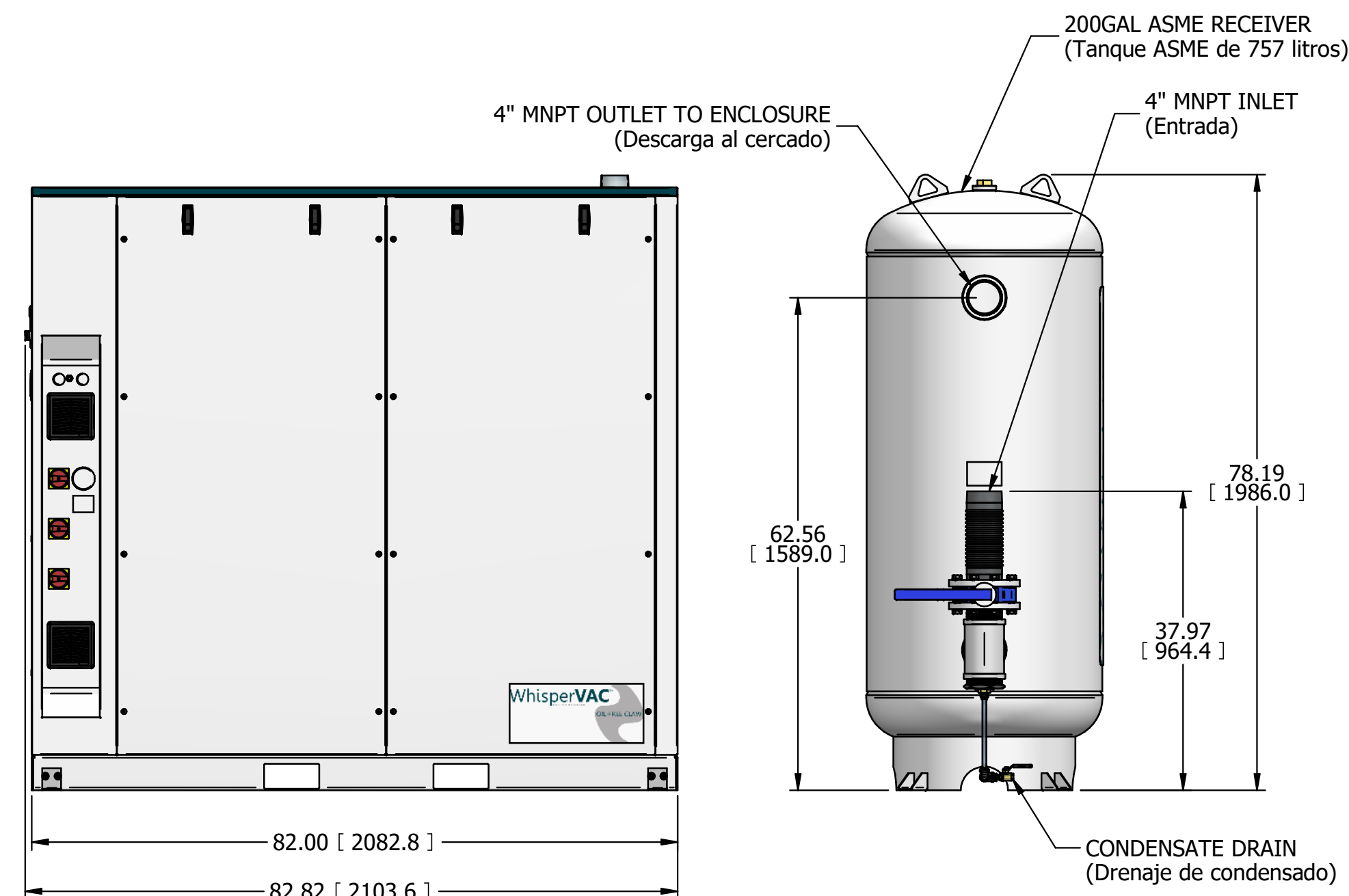
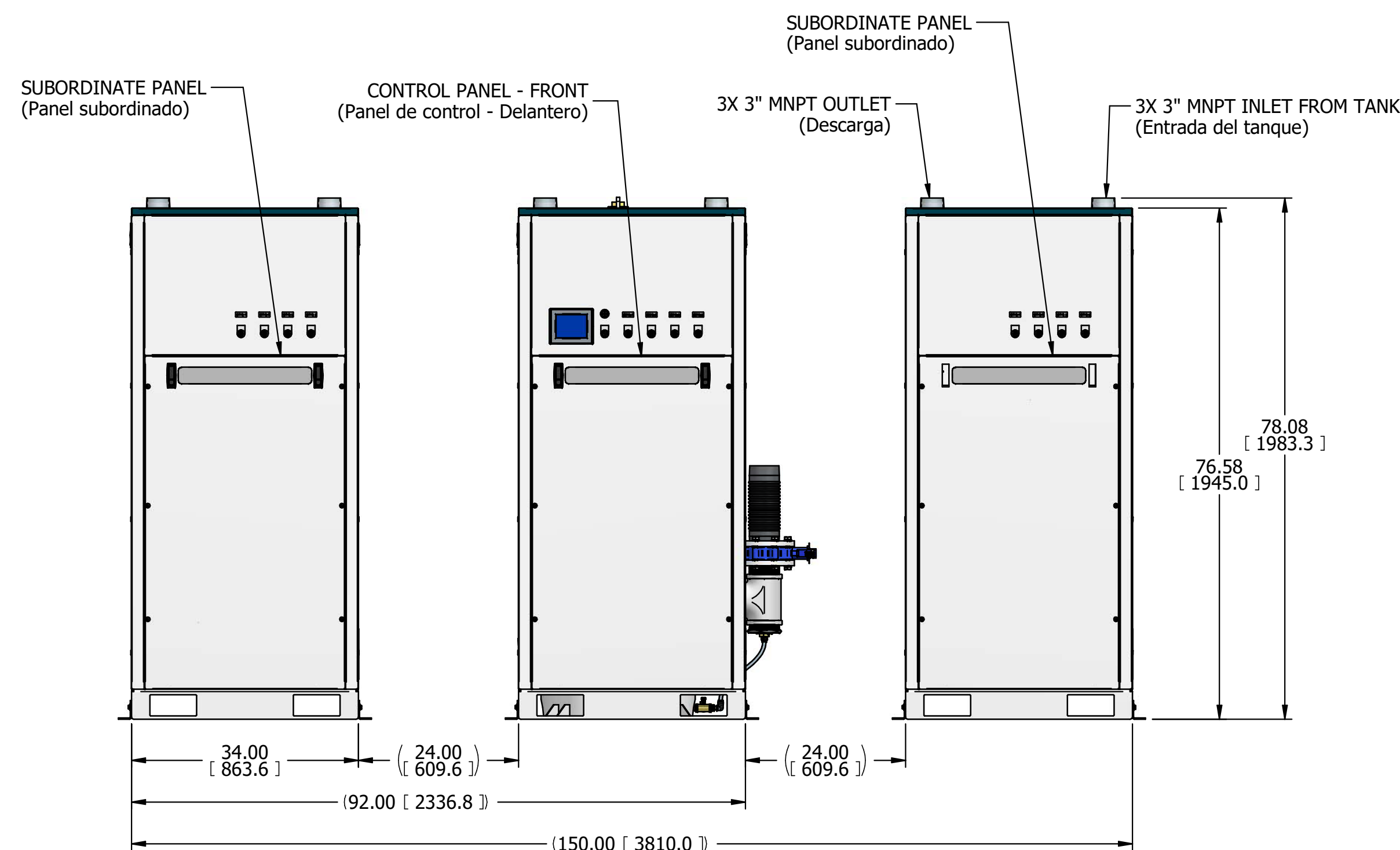
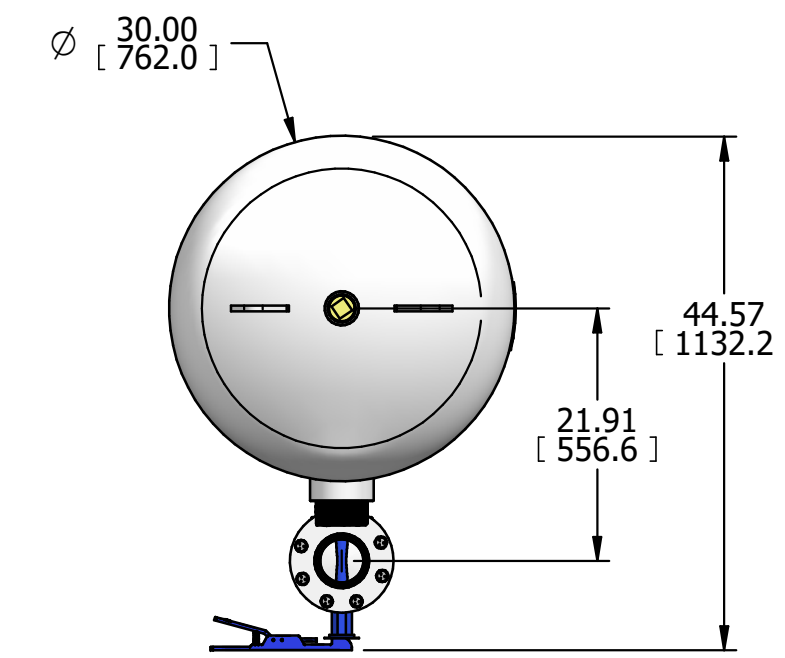

- NOTES:
- APPROXIMATE WEIGHT: 9481 LBS
 - A MINIMUM OF 24" CLEARANCE IS RECOMMENDED AROUND THE ENTIRE UNIT. CLEARANCE FOR CONTROL PANEL SHALL BE IN ACCORDANCE WITH OSHA/NEC REQUIREMENTS.
 - ALL PLUMBING FROM TANK OUTLET TO ENCLOSURE INLET(S) SHALL BE FIELD-SUPPLIED.
 - PESO APROXIMADO: 4300 kg
 - RECOMENDAMOS QUE EL ESPACIO LIBRE ALREDEDOR DEL SISTEMA DEBE SER COMO MÍNIMO 24" (600 mm). EL ESPACIO LIBRE PARA EL TABLERO DE CONTROL DEBERÁ ESTAR DE ACUERDO CON LOS REQUERIMIENTOS DE SEGURIDAD DE LA OSHA/NEC.
 - TODA LA PLOMERÍA DESDE LA DESCARGA DEL TANQUE HASTA LA(S) ENTRADA(S) DEL CERCADO DEBE SER SUMINISTRADA POR EL CLIENTE.

SYMBOL LEGEND		DRAWINGS TO CONFORM TO CURRENT REVISION OF THE FOLLOWING ANSI STANDARDS:	
		Y14.3 MULTI AND SECTIONAL VIEW DWGS	Y14.5 DIMENSIONING AND TOLERANCING
TOLERANCES, UNLESS OTHERWISE SPECIFIED:	SOLID EDGE DRAWING	DO NOT SCALE DRAWING FOR DIMENSIONS	
0.XX ± .05			
0.XXX ± .005	INCH [mm]	SHEET 1 OF 2	SCALE 1:16.67
± .1			
CONFIDENTIAL DISCLOSURE		AUTHOR	REVISION DATE
This drawing is the property of POWEREX of the SCOTT FEZTER COMPANY and is subject to return on demand. Its contents are confidential and must not be copied or admitted to outside parties for use or examination.		BKIPLINGER	1/8/2024
APPROVALS ON FILE IN PDM			
ITEM NO:	752399	POWEREX	
MATERIAL:	N/A	150 PRODUCTION DRIVE, HARRISON OH 45030 (888) 769-7979	
DESCRIPTION	LAB VAC ENCL 15 HP PENTAPLX CLAW 200G TANK	DRAWING NUMBER	LVECP1505xx1
		REVISION	A
		SIZE	D

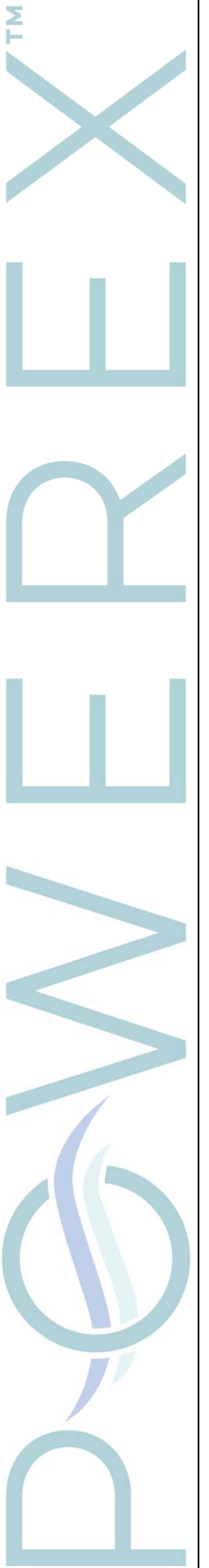

LVECP1505xx1

LAB VAC ENCL 15 HP PENTAPLX CLAW 200G TANK

REVISION NOTES		
DESCRIPTION	ECN	PR/NOR
RELEASE TO PRODUCTION	PXEC0481	XXXXXXXX

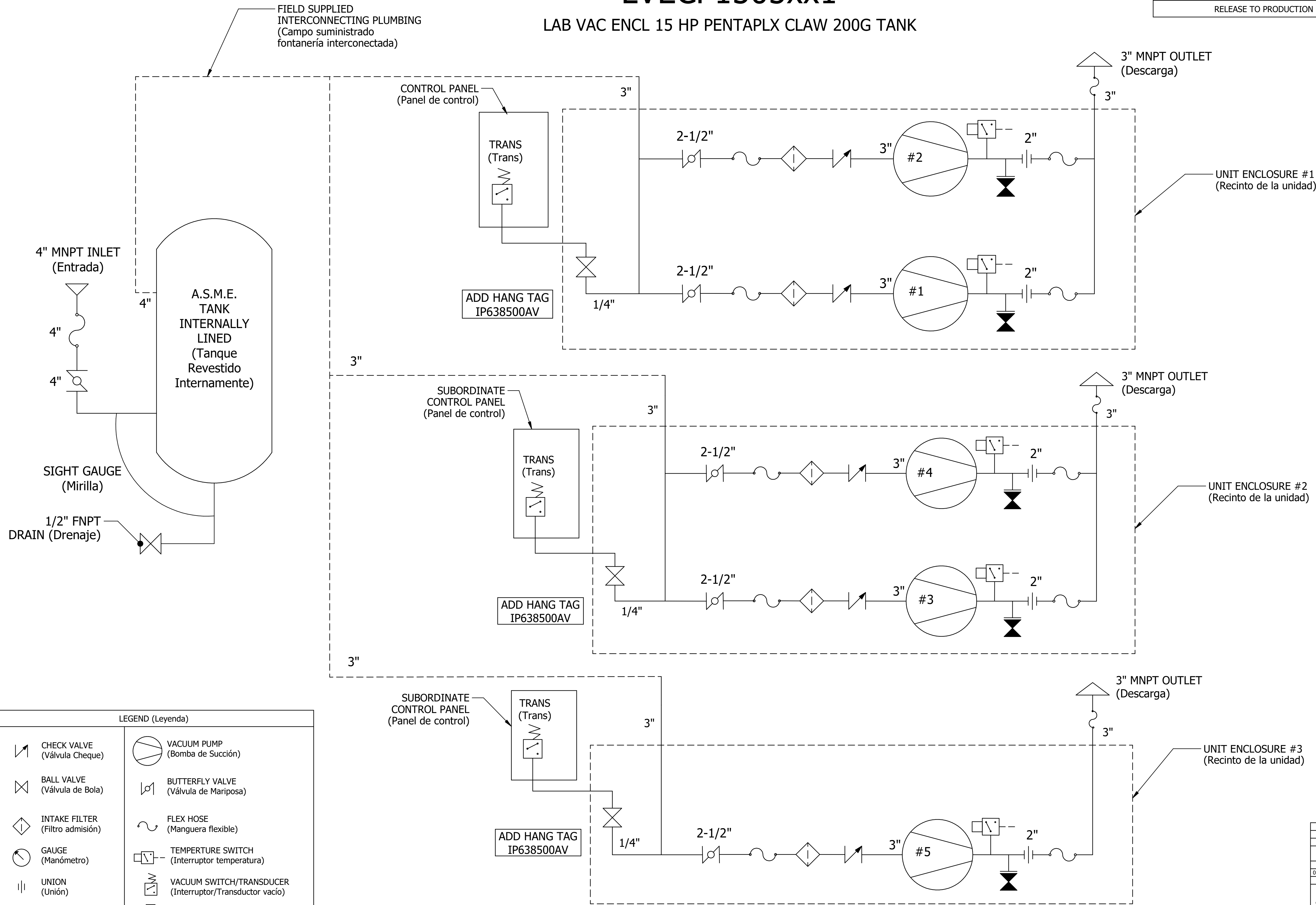

POWEREX™

LEGEND (Leyenda)	
	CHECK VALVE (Válvula Cheque)
	BALL VALVE (Válvula de Bola)
	INTAKE FILTER (Filtro admisión)
	GAUGE (Manómetro)
	UNION (Unión)
	DRAIN COCK (Grifo de Drenaje)
	AIR LINE (Tubería de Aire)
	VACUUM PUMP (Bomba de Succión)
	BUTTERFLY VALVE (Válvula de Mariposa)
	FLEX HOSE (Manguera flexible)
	TEMPERTURE SWITCH (Interruptor temperatura)
	VACUUM SWITCH/TRANSDUCER (Interruptor/Transductor vacío)
	SOLENOID VALVE (Válvula solenoide)
	CONDENSATE LINE (Línea de Condensado)

SYMBOL LEGEND		DRAWINGS TO CONFORM TO CURRENT REVISION OF THE FOLLOWING STANDARDS:	
TOLERANCES, UNLESS OTHERWISE SPECIFIED:		Y14.3 MULTI AND SECTIONAL VIEW DWGS	
0.XXX ± .005		Y14.5 DIMENSIONING AND TOLERANCING	
± .1		DO NOT SCALE DRAWING FOR DIMENSIONS	
INCH [mm]		SHEET 2 OF 2 SCALE 1:1	
CONFIDENTIAL DISCLOSURE		APPROVALS ON FILE IN PLM	
This drawing is the property of POWEREX of the SCOTT FEZTER COMPANY and is subject to return on demand. Its contents are confidential and must not be copied or submitted to outside parties for use or examination.		AUTHOR	
		REVISION DATE	
		BKIPLINGER 1/8/2024	
ITEM NO: 752399		POWEREX	
MATERIAL: N/A		150 PRODUCTION DRIVE, HARRISON OH 45030 (888) 769-7979	
DESCRIPTION: LAB VAC ENCL 15 HP PENTAPLX CLAW 200G TANK		DRAWING NUMBER: LVECP1505xx1	
		REVISION: A	
		SIZE: D	