

MVECH1505xx1

MVAC ENCL 15 HP HEXAPLEX CLAW 200G TANK

REVISION NOTES		
DESCRIPTION	ECN	PR/NOR
RELEASE TO PRODUCTION	PXEC0481	XXXXXXXX

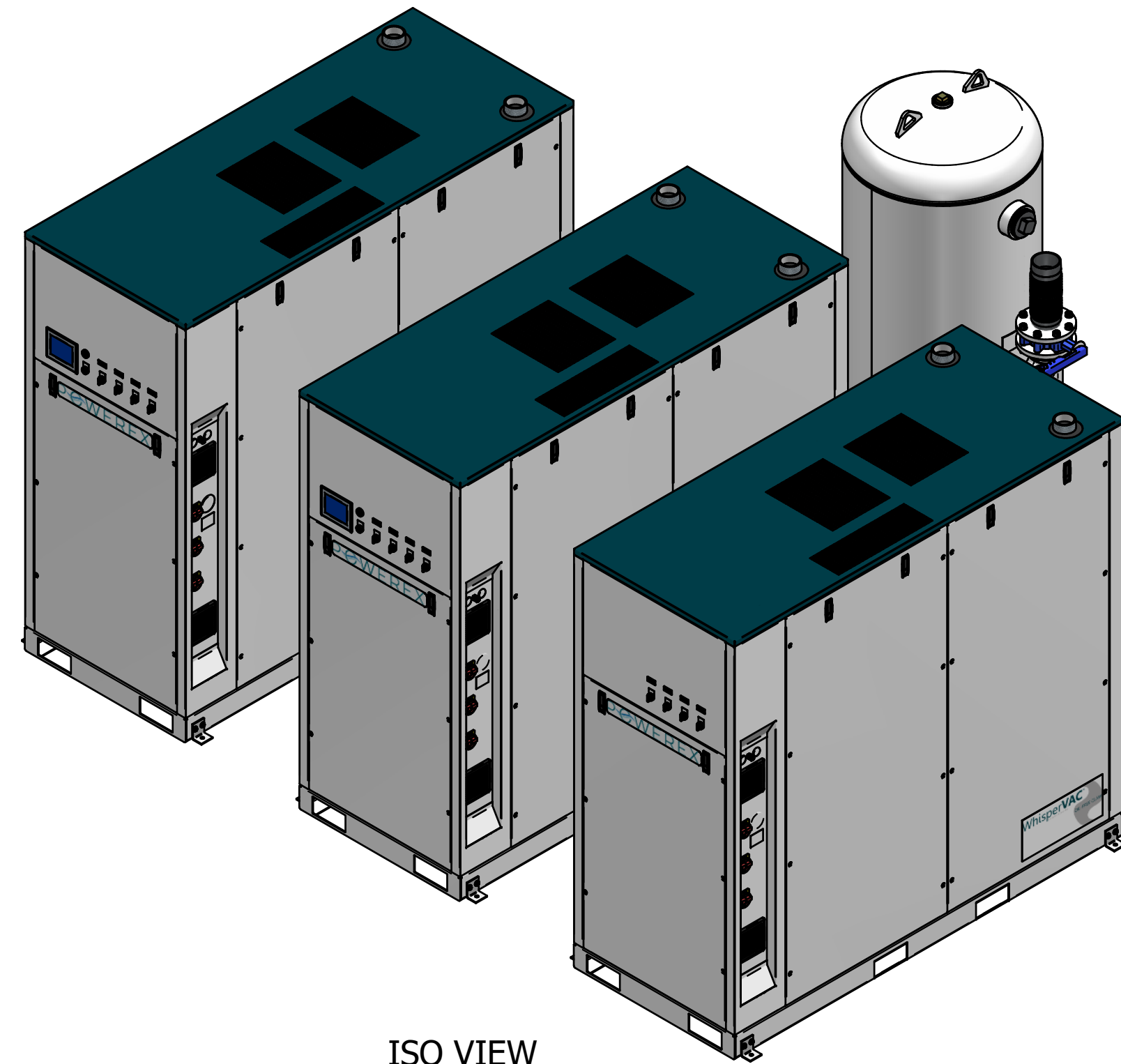

ISO VIEW

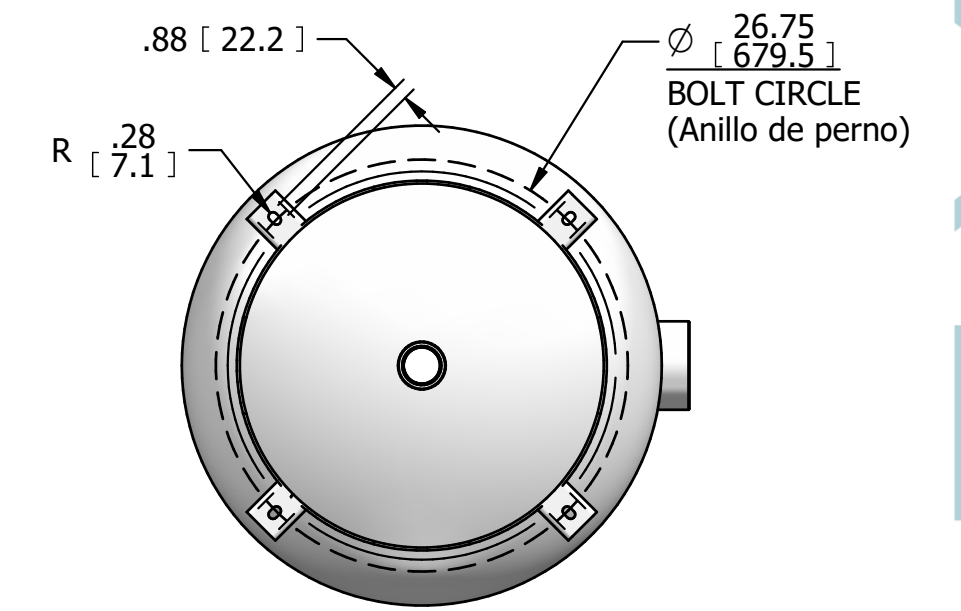
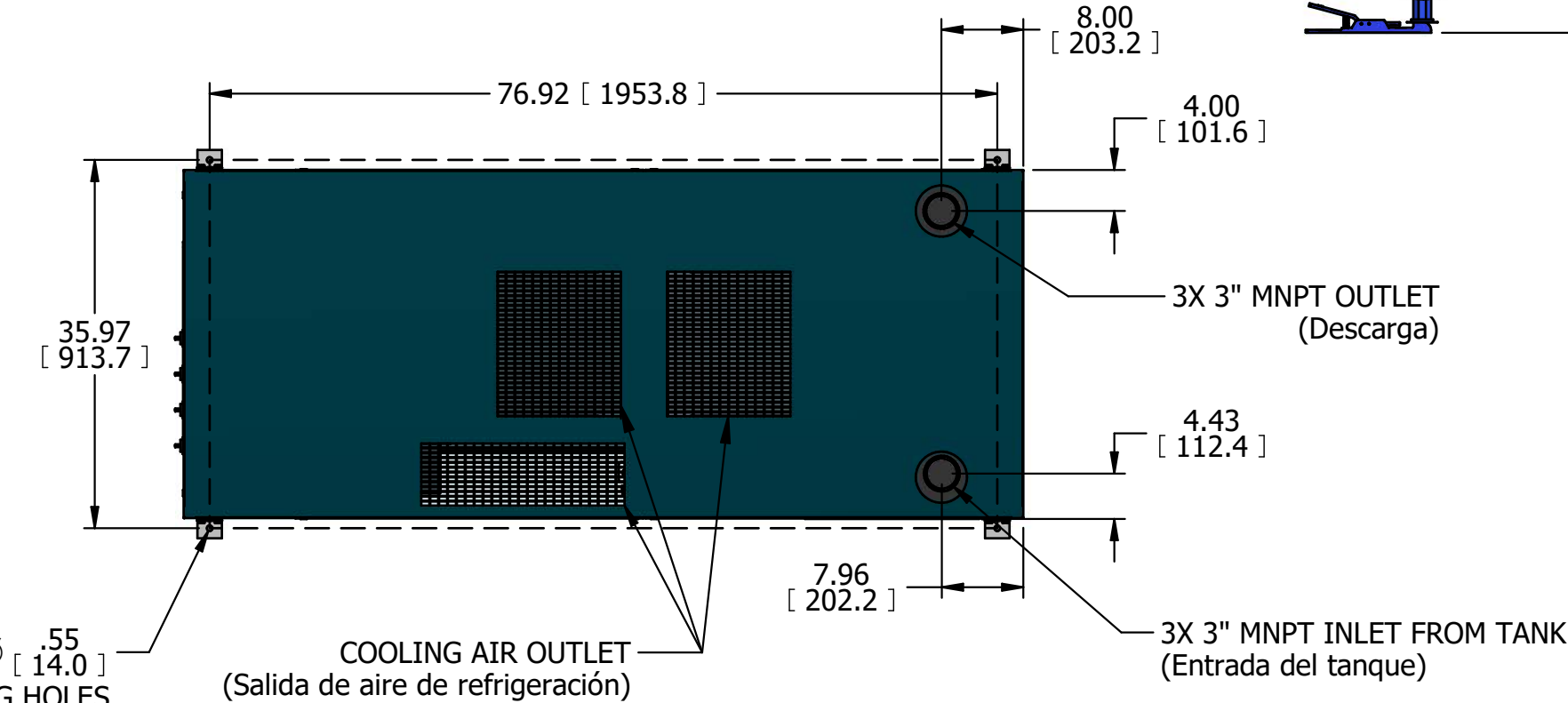
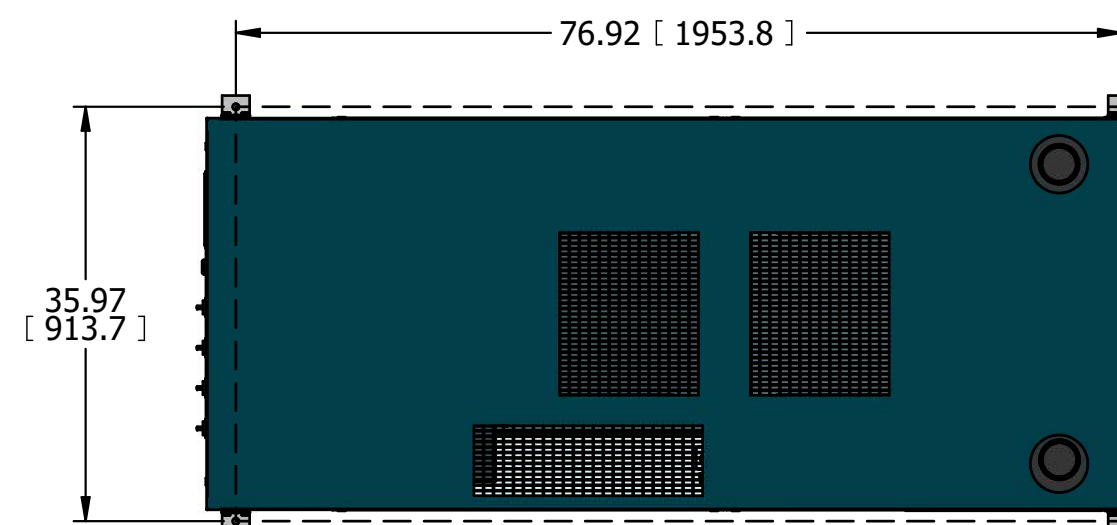
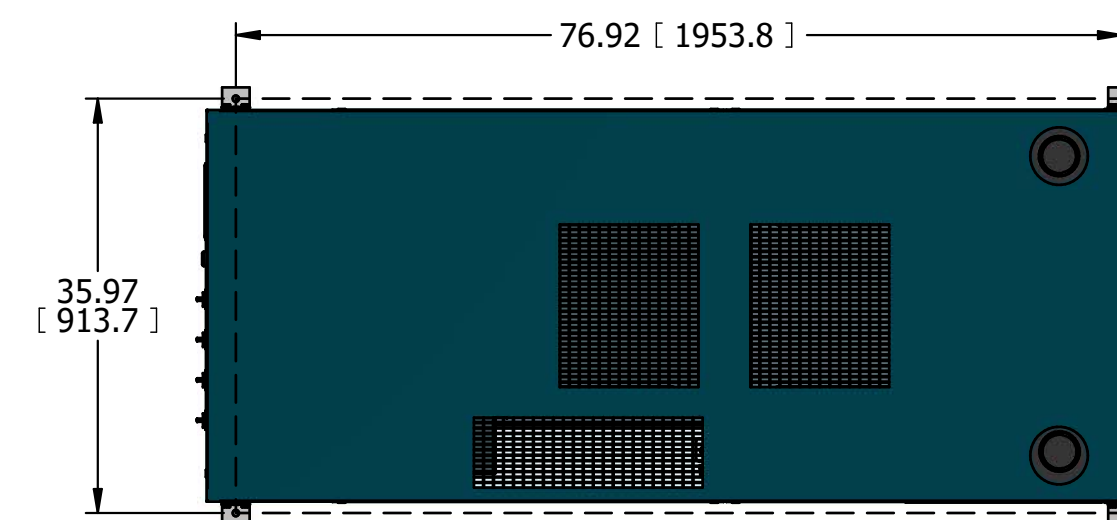

4X FLOOR MOUNTING SLOTS
(Ranuras de Montaje)

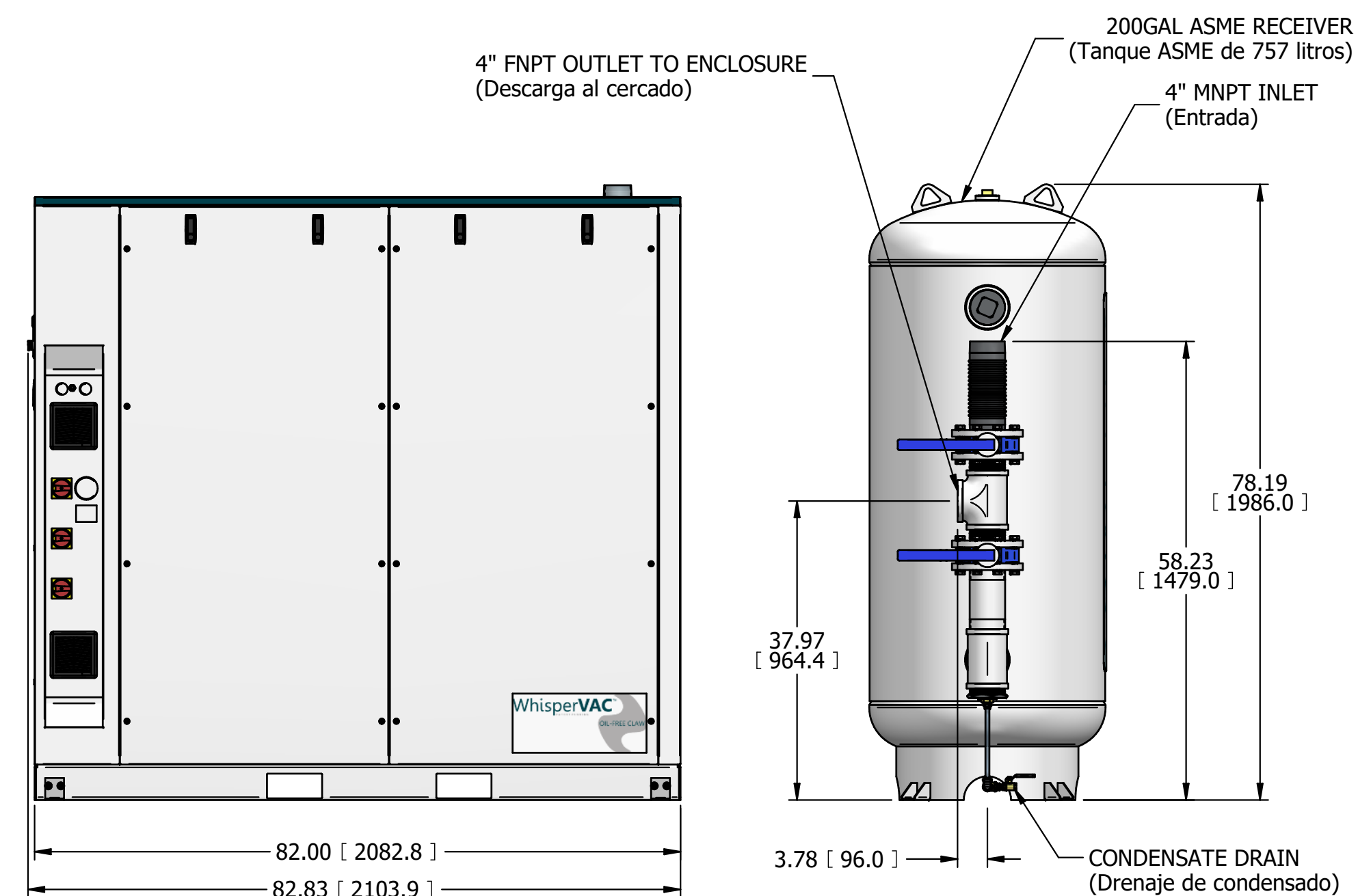
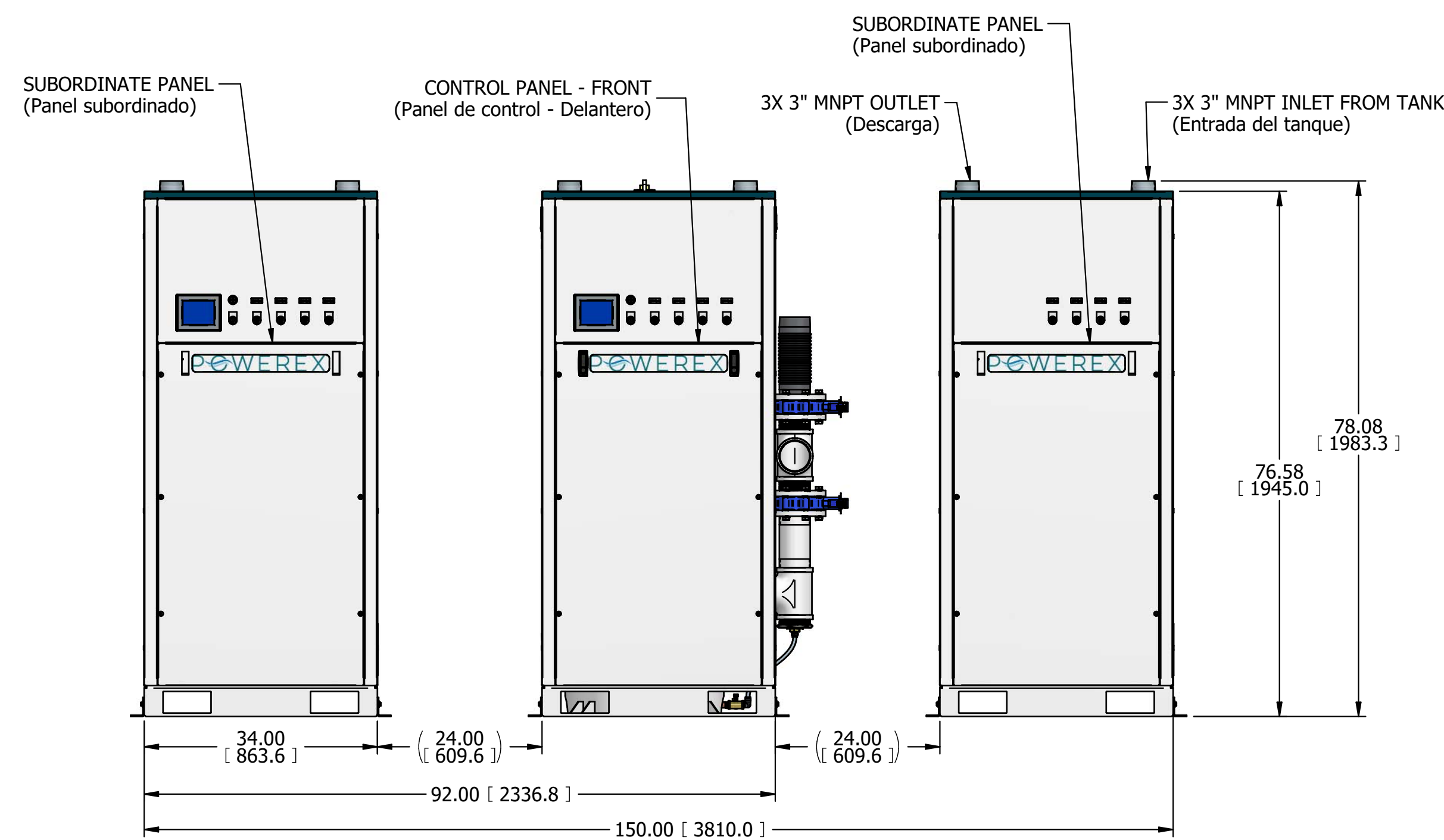
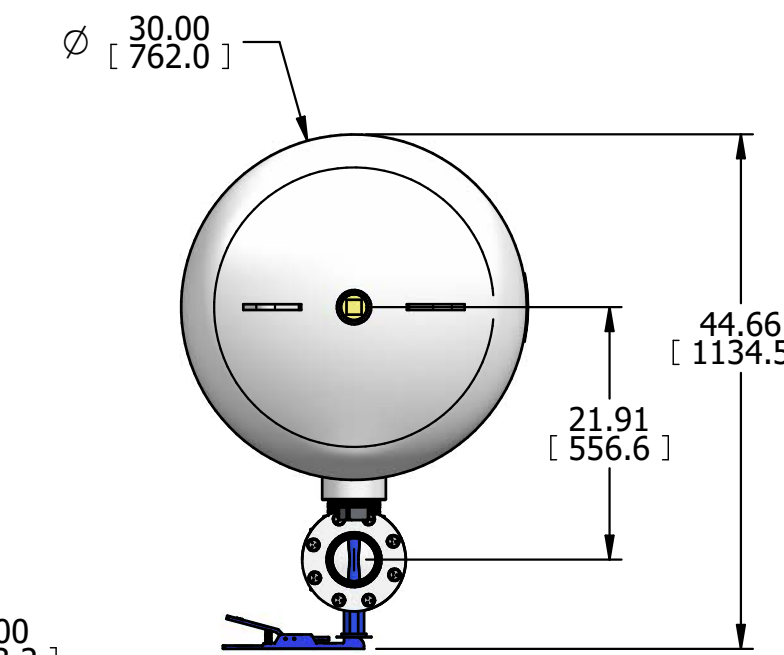

- NOTES:
- APPROXIMATE WEIGHT: 6117 LBS
 - A MINIMUM OF 24" CLEARANCE IS RECOMMENDED AROUND THE ENTIRE UNIT. CLEARANCE FOR CONTROL PANEL SHALL BE IN ACCORDANCE WITH OSHA/NEC REQUIREMENTS.
 - ALL PLUMBING FROM TANK OUTLET TO ENCLOSURE INLET(S) SHALL BE FIELD-SUPPLIED.
 - SYSTEM DESIGNED IN COMPLIANCE WITH U.S. NFPA '99, LATEST EDITION.
 - PESO APROXIMADO: 2774 kg
 - RECOMENDAMOS QUE EL ESPACIO LIBRE ALREDEDOR DEL SISTEMA DEBE SER COMO MÍNIMO 24" (600 mm). EL ESPACIO LIBRE PARA EL TABLERO DE CONTROL DEBERÁ ESTAR DE ACUERDO CON LOS REQUERIMIENTOS DE SEGURIDAD DE LA OSHA/NEC.
 - TODA LA PLOMERÍA DESDE LA DESCARGA DEL TANQUE HASTA LA(S) ENTRADA(S) DEL CERCADO DEBE SER SUMINISTRADA POR EL CLIENTE.
 - EL SISTEMA ESTÁ DISEÑADO DE ACUERDO CON LA ÚLTIMA EDICIÓN DE LA NFPA 99.

SYMBOL LEGEND		DRAWINGS TO CONFORM TO CURRENT REVISION OF THE FOLLOWING STANDARDS:	
		Y14.3 MULTI AND SECTIONAL VIEW DWGS	Y14.5 DIMENSIONING AND TOLERANCING
TOLERANCES, UNLESS OTHERWISE SPECIFIED:	SOLID EDGE DRAWING	DO NOT SCALE DRAWING FOR DIMENSIONS	
0.XX ± .005			
0.XXX ± .005	INCH [mm]	SHEET 1 OF 2	SCALE 1:16.67
± .1			
CONFIDENTIAL DISCLOSURE This drawing is the property of POWEREX of the SCOTT FEZTER COMPANY and is subject to return on demand. Its contents are confidential and must not be copied or submitted to outside parties for use or examination.		AUTHOR	REVISION DATE
		bkiplinger	1/5/2024
ITEM NO:	752392	APPROVALS ON FILE IN PLM	
MATERIAL:	N/A	POWEREX	
		150 PRODUCTION DRIVE, HARRISON OH 45030 (888) 769-7929	
DESCRIPTION	MVAC ENCL 15 HP HEXAPLEX CLAW 200G TANK	DRAWING NUMBER	REVISION
		MVECH1505xx1	A D

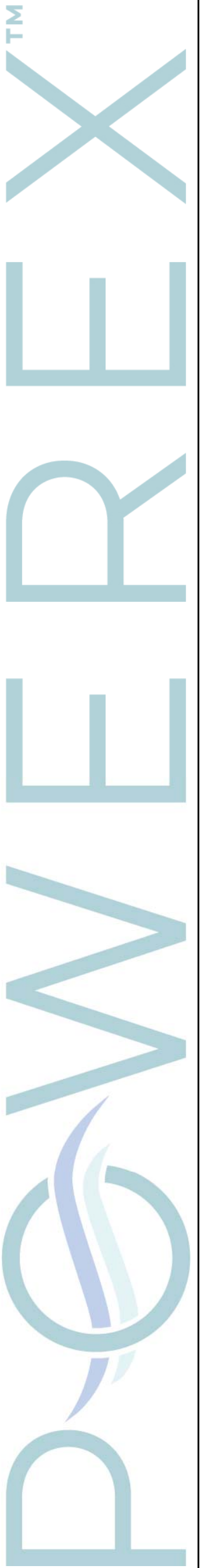

MVECH1505xx1

MVAC ENCL 15 HP HEXAPLEX CLAW 200G TANK

REVISION NOTES		
DESCRIPTION	ECN	PR/NOR
RELEASE TO PRODUCTION	PXEC0481	XXXXXXXX

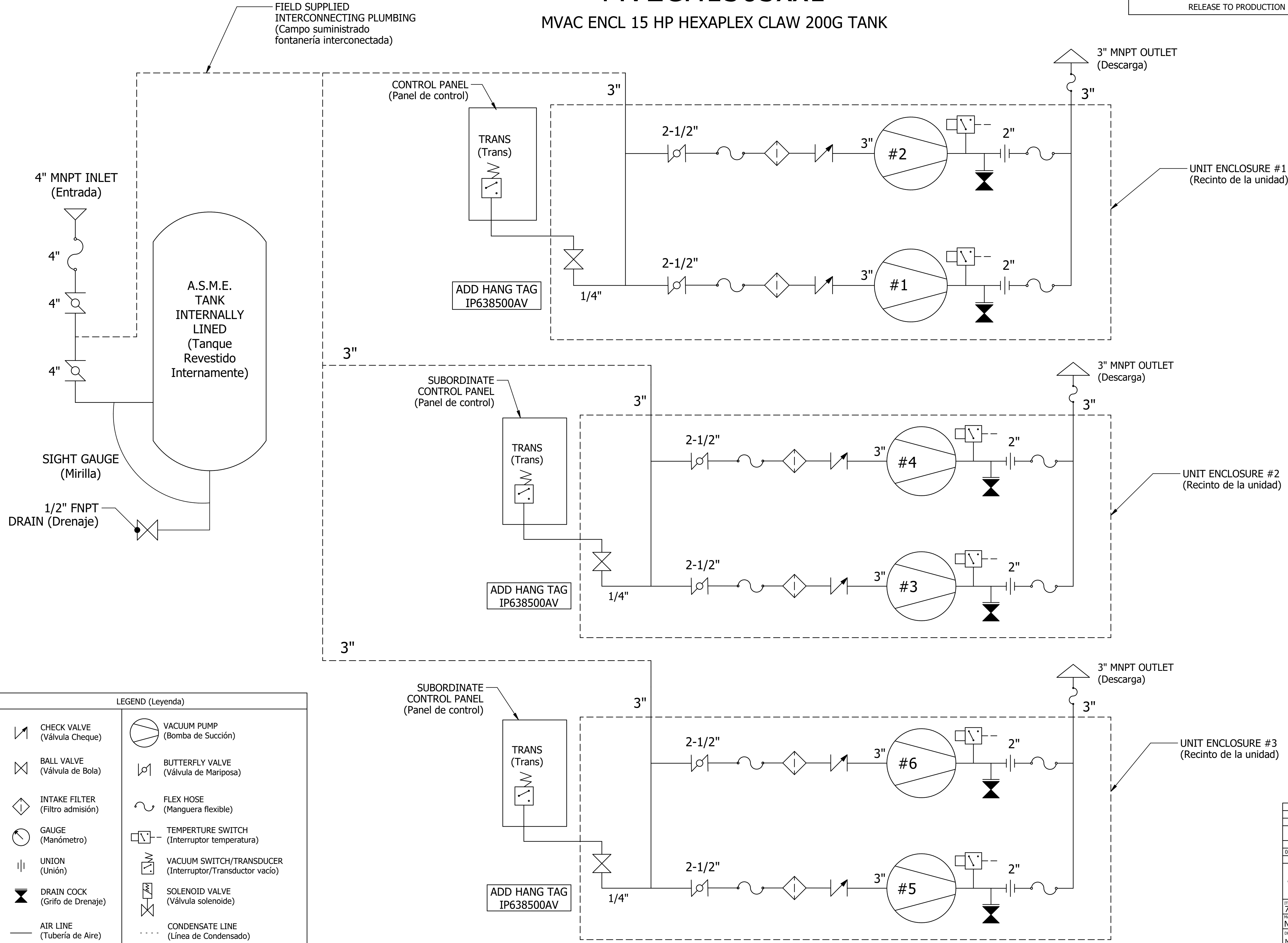

POWEREX™

LEGEND (Leyenda)

	CHECK VALVE (Válvula Cheque)		VACUUM PUMP (Bomba de Succión)
	BALL VALVE (Válvula de Bola)		BUTTERFLY VALVE (Válvula de Mariposa)
	INTAKE FILTER (Filtro admisión)		FLEX HOSE (Manguera flexible)
	GAUGE (Manómetro)		TEMPERTURE SWITCH (Interruptor temperatura)
	UNION (Unión)		VACUUM SWITCH/TRANSDUCER (Interruptor/Transductor vacío)
	DRAIN COCK (Grifo de Drenaje)		SOLENOID VALVE (Válvula solenoide)
	AIR LINE (Tubería de Aire)		CONDENSATE LINE (Línea de Condensado)

SYMBOL LEGEND		DRAWINGS TO CONFORM TO CURRENT REVISION OF THE FOLLOWING STANDARDS:	
TOLERANCES, UNLESS OTHERWISE SPECIFIED:		ASME Y14.3 MULTI-VIEW AND SECTIONAL VIEW DWGS	
0.XX ± 0.05	SOLID EDGE DRAWING	DO NOT SCALE DRAWING FOR DIMENSIONS	
0.XXX ± 0.005	INCH [mm]	SHEET 2 OF 2	SCALE 1:1
± 1		APPROVALS ON FILE IN PLM	
CONFIDENTIAL DISCLOSURE		AUTHOR	REVISION DATE
This drawing is the property of POWEREX of the SCOTT FEZER COMPANY and is subject to return on demand. Its contents are confidential and must not be copied or submitted to outside parties for use or examination.		bkiplinger	1/5/2024
ITEM NO: 752392	POWEREX		
MATERIAL: N/A	150 PRODUCTION DRIVE, HARRISON OH 45030 (888) 769-7979		
DESCRIPTION: MVAC ENCL 15 HP HEXAPLEX CLAW 200G TANK	DRAWING NUMBER: MVECH1505xx1	REVISION: A	SIZE: D