

MVECT1505xx1

MVAC ENCLOSURE 15 HP TRIPLEX CLAW 200G TANK

REVISION NOTES		
DESCRIPTION	ECN	PR/NOR
RELEASE TO PRODUCTION	PXEC0481	XXXXXXXX

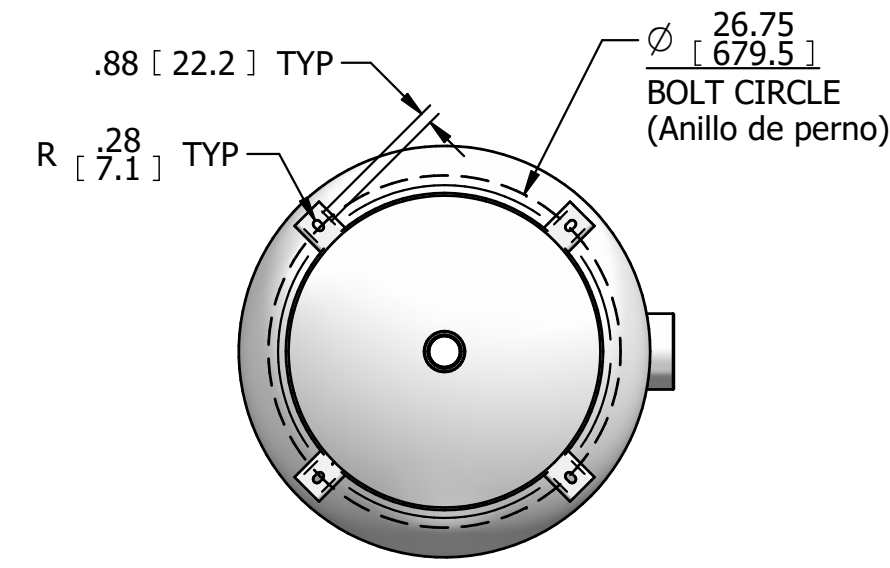

FLOOR MOUNTING SLOTS
(Ranuras de Montaje)

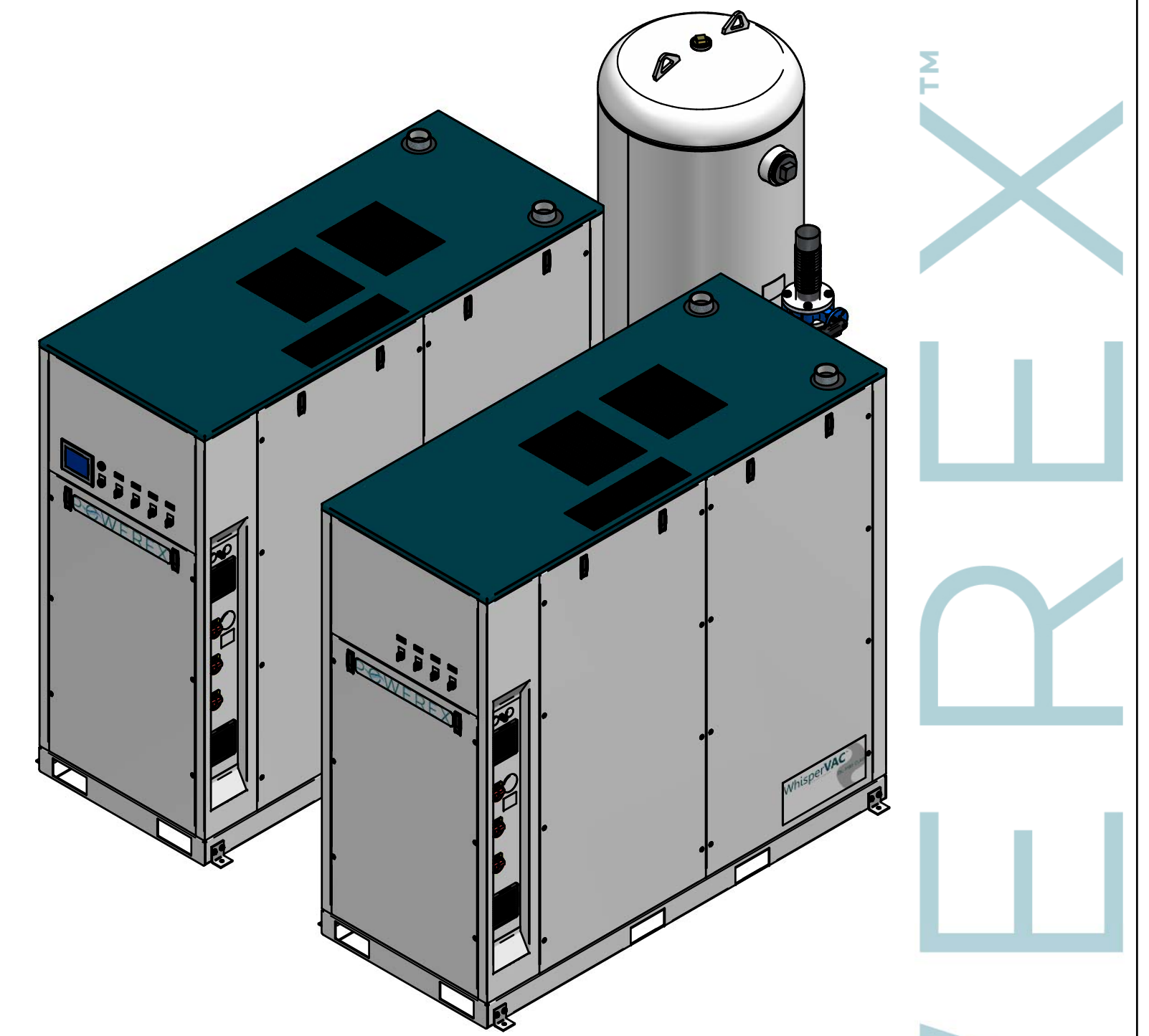
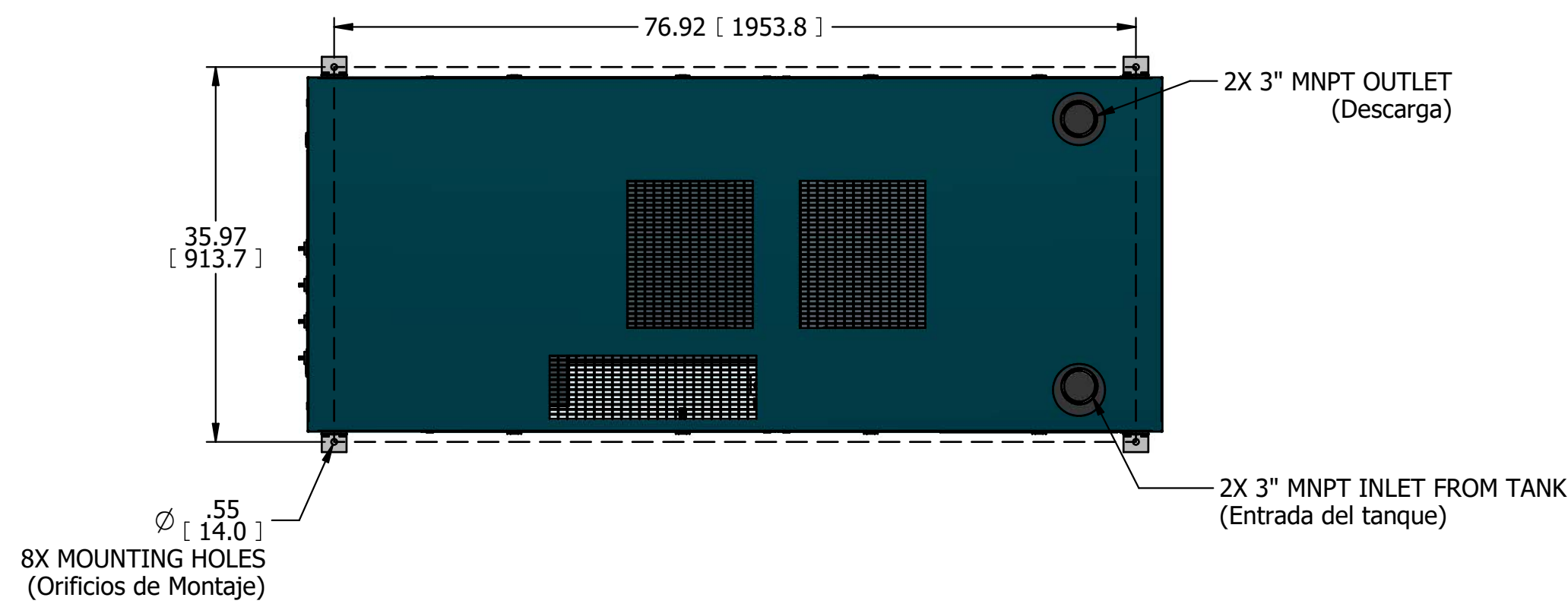
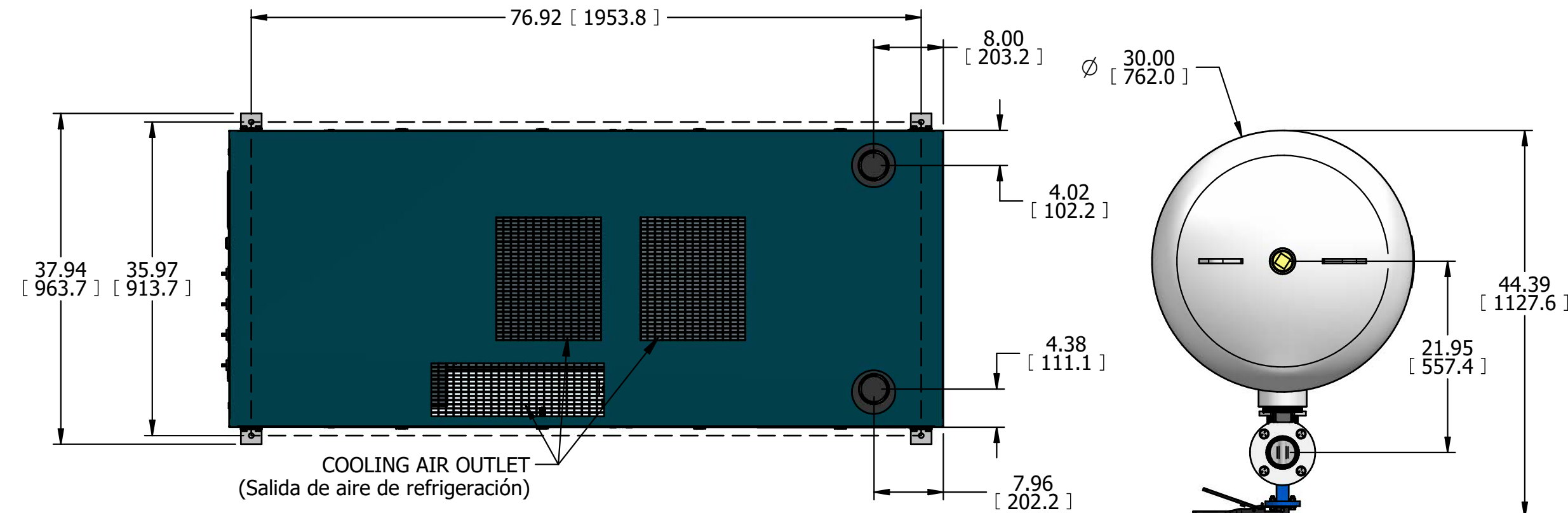

ISO VIEW

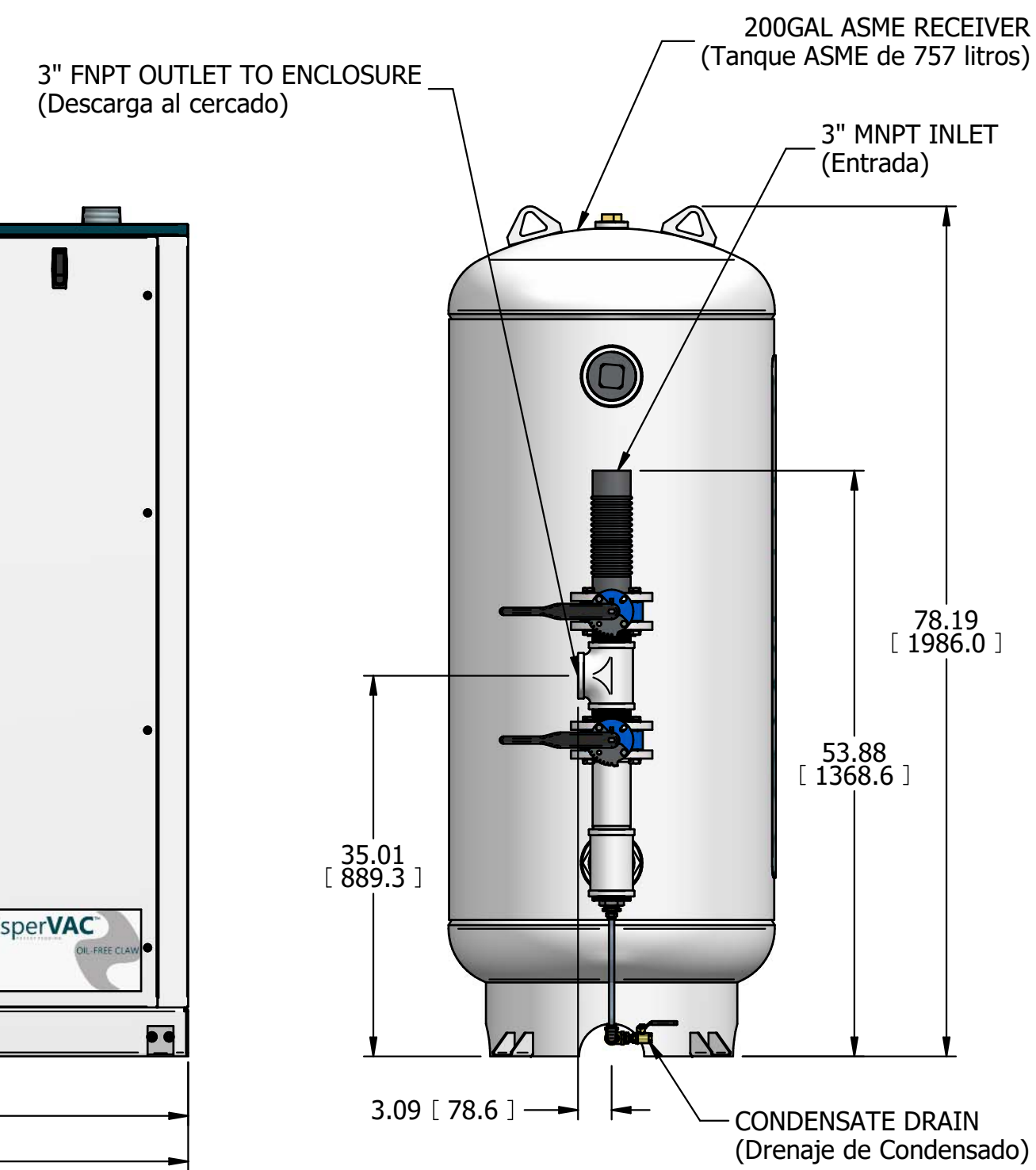
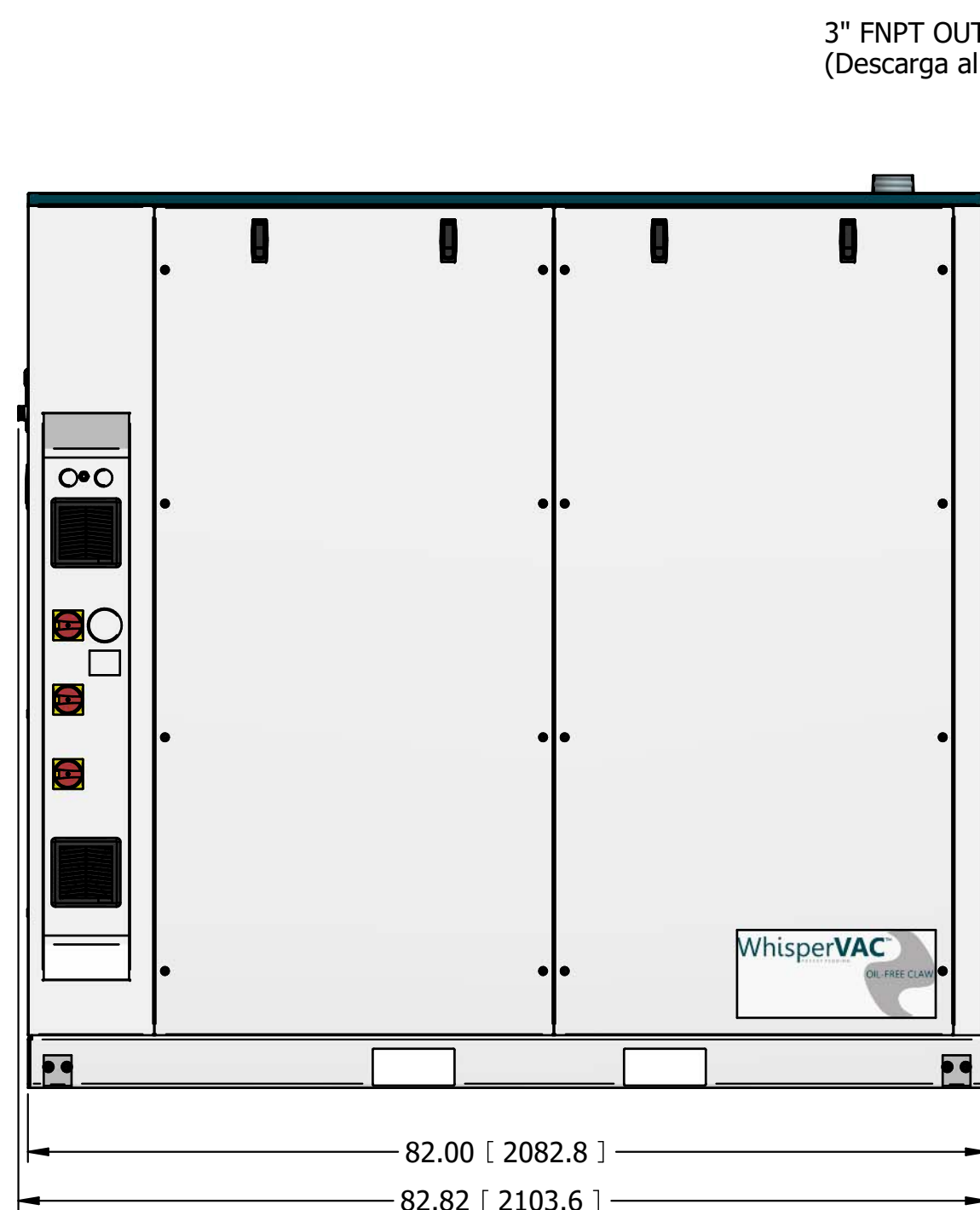
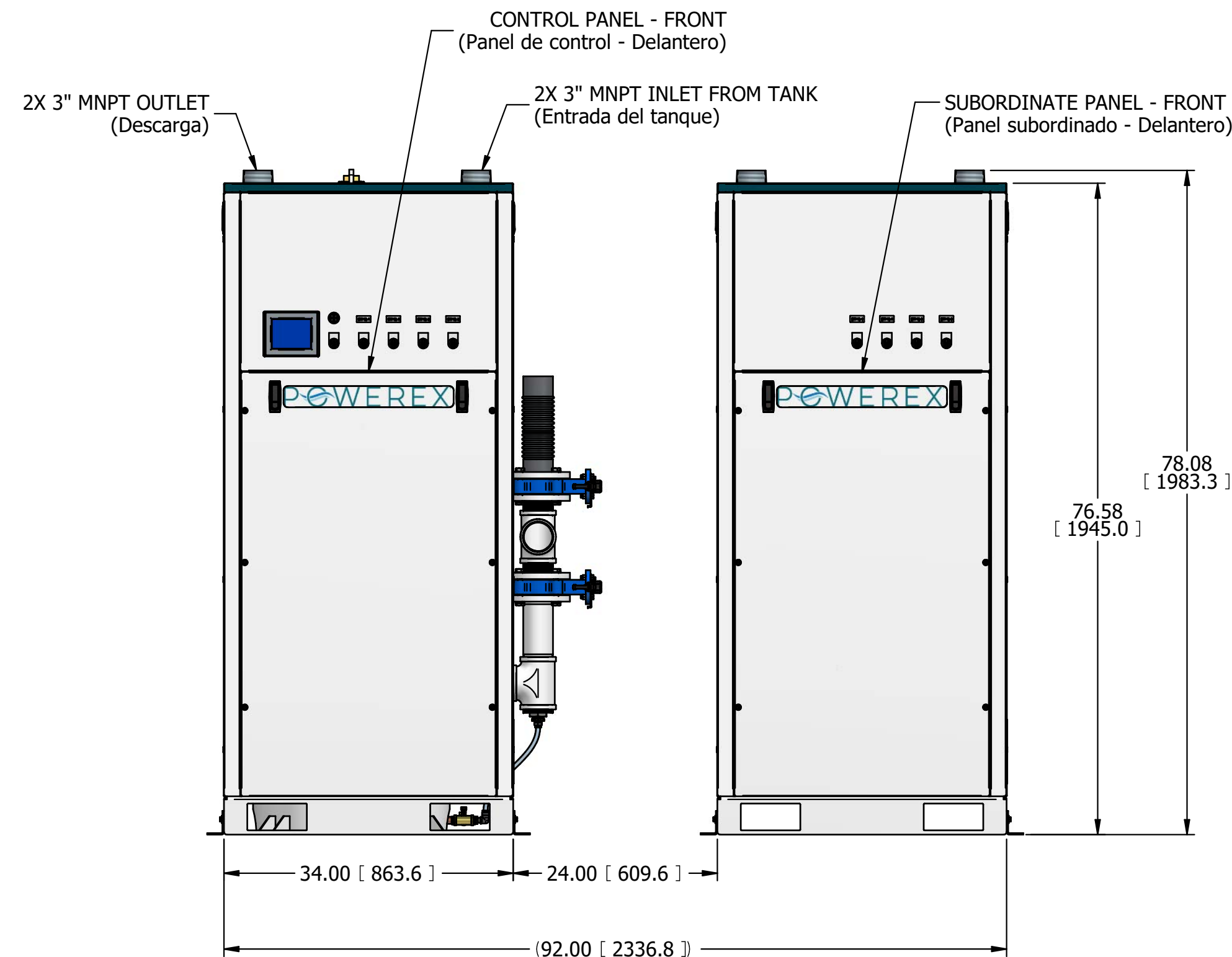
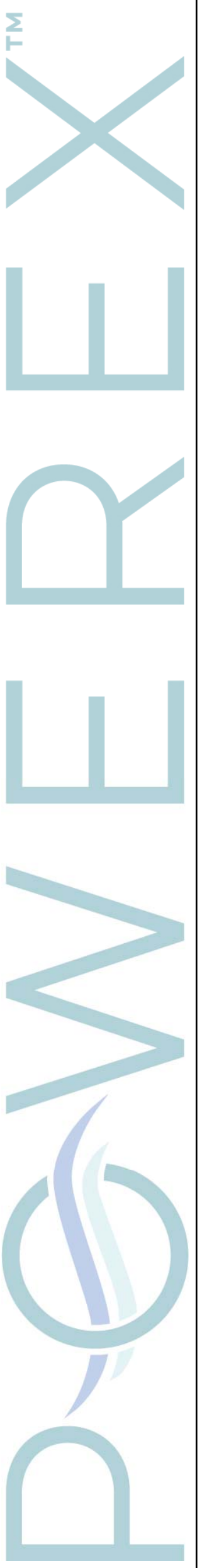

- NOTES:
- APPROXIMATE WEIGHT: 5326 LBS
 - A MINIMUM OF 24" CLEARANCE IS RECOMMENDED AROUND THE ENTIRE UNIT. CLEARANCE FOR CONTROL PANEL SHALL BE IN ACCORDANCE WITH OSHA/NEC REQUIREMENTS.
 - ALL PLUMBING FROM TANK OUTLET TO ENCLOSURE INLET(S) SHALL BE FIELD-SUPPLIED.
 - SYSTEM DESIGNED IN COMPLIANCE WITH U.S. NFPA '99, LATEST EDITION.
- RECOMENDAMOS QUE EL ESPACIO LIBRE ALREDEDOR DEL SISTEMA DEBE SER COMO MÍNIMO 24" (600 mm). EL ESPACIO LIBRE PARA EL TABLERO DE CONTROL DEBERÁ ESTAR DE ACUERDO CON LOS REQUERIMIENTOS DE SEGURIDAD DE LA OSHA/NEC.
 - TODA LA PLOMERÍA DESDE LA DESCARGA DEL TANQUE HASTA LA(S) ENTRADA(S) DEL CERCADO DEBE SER SUMINISTRADA POR EL CLIENTE.
 - EL SISTEMA ESTÁ DISEÑADO DE ACUERDO CON LA ÚLTIMA EDICIÓN DE LA NFPA 99.

SYMBOL LEGEND		DRAWINGS TO CONFORM TO CURRENT REVISION OF THE FOLLOWING AISC STANDARDS:	
		Y14.1 MULTI-VIEW AND SECTIONAL VIEW DWGS	Y14.5 DIMENSIONING AND TOLERANCING
TOLERANCES, UNLESS OTHERWISE SPECIFIED	SOLID EDGE DRAWING	DO NOT SCALE DRAWING FOR DIMENSIONS	
0.XXX ± .005		SHEET 1 OF 2	SCALE 1:14
0.XXX ± .005	INCH [mm]		
± .1			
CONFIDENTIAL DISCLOSURE		AUTHOR	REVISION DATE
This drawing is the property of POWEREX of the SCOTT FEZTER COMPANY and is subject to return on demand. Its contents are confidential and must not be copied or submitted to outside parties for use or examination.		bkiplinger	1/8/2024
APPROVALS ON FILE IN PLM			
ITEM NO:	752384	POWEREX	
MATERIAL:	N/A	150 PRODUCTION DRIVE, HARRISON OH 45030 (888) 769-7929	
DESCRIPTION	MVAC ENCLOSURE 15 HP TRIPLEX CLAW 200G TANK	DRAWING NUMBER	MVECT1505xx1
		REVISION	A
		SIZE	D

MVECT1505xx1

MVAC ENCLOSURE 15 HP TRIPLEX CLAW 200G TANK

REVISION NOTES

DESCRIPTION	ECN	PR/NOR
RELEASE TO PRODUCTION	PXEC0481	XXXXXXXX

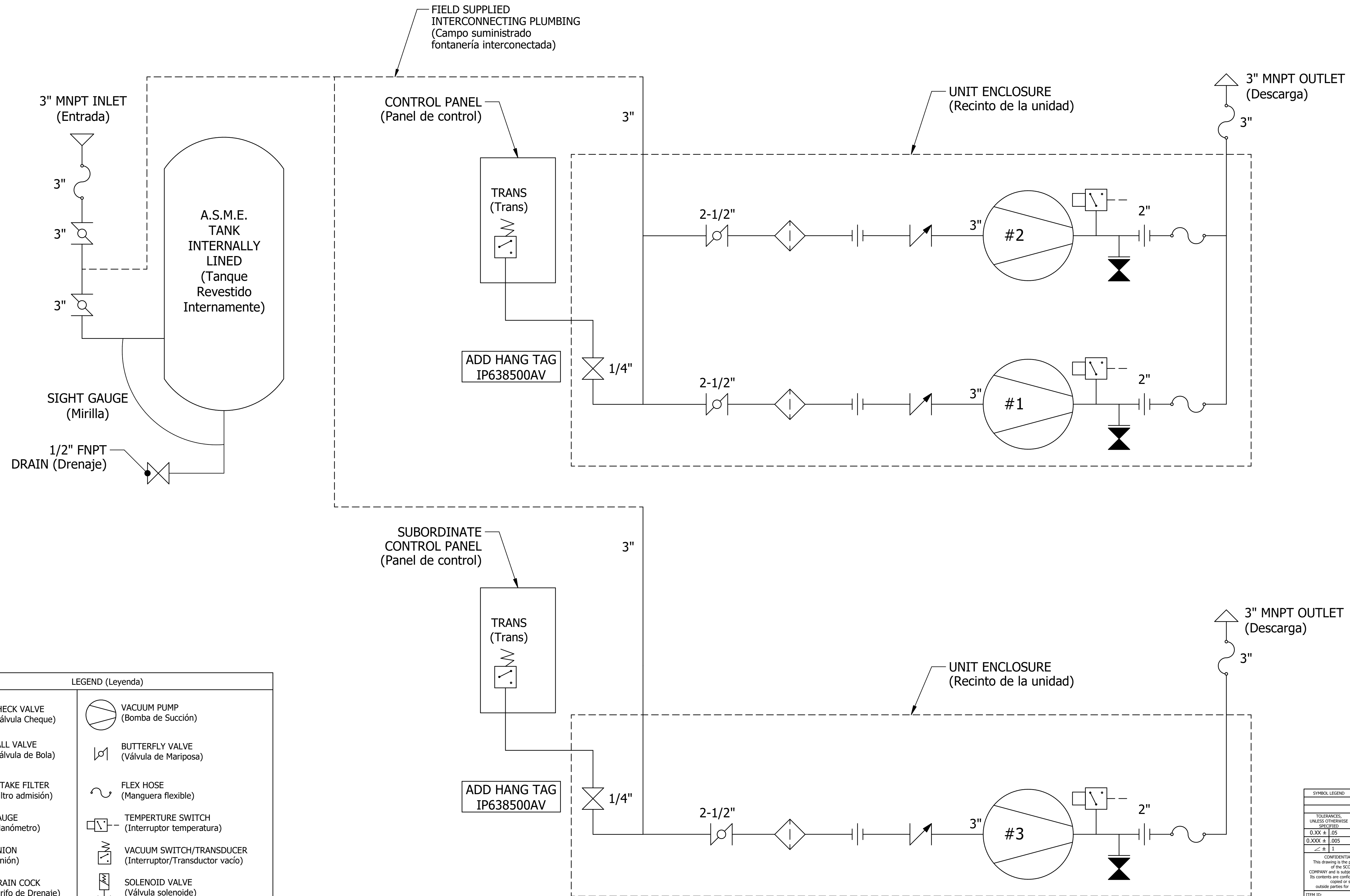

LEGEND (Leyenda)

	CHECK VALVE (Válvula Cheque)		VACUUM PUMP (Bomba de Succión)
	BALL VALVE (Válvula de Bola)		BUTTERFLY VALVE (Válvula de Mariposa)
	INTAKE FILTER (Filtro admisión)		FLEX HOSE (Manguera flexible)
	GAUGE (Manómetro)		TEMPERATURE SWITCH (Interruptor temperatura)
	UNION (Unión)		VACUUM SWITCH/TRANSDUCER (Interruptor/Transductor vacío)
	DRAIN COCK (Grifo de Drenaje)		SOLENOID VALVE (Válvula solenoide)
	AIR LINE (Tubería de Aire)		CONDENSATE LINE (Línea de Condensado)

POWEREX™

SYMBOL LEGEND		DRAWINGS TO CONFORM TO CURRENT REVISION OF THE FOLLOWING AISC STANDARDS:		
TOLERANCES, UNLESS OTHERWISE SPECIFIED:		A13.1 MULTI AND SECTIONAL VIEW DWGS		
0.XX ± .005	SOLID EDGE DRAWING	DO NOT SCALE DRAWING FOR DIMENSIONS		
0.XXX ± .005	INCH [mm]	SHEET 2 OF 2	SCALE	1:1
± 1				
CONFIDENTIAL DISCLOSURE		AUTHOR	REVISION DATE	APPROVALS ON FILE IN PLM
This drawing is the property of POWEREX of the SCOTT FEZTER COMPANY and is subject to return on demand. Its contents are confidential and must not be copied or submitted to outside parties for use or examination.		bkiplinger	1/8/2024	
ITEM NO: 752384		POWEREX™		
MATERIAL: N/A		150 PRODUCTION DRIVE, HARRISON OH 45030 (888) 769-7979		
DESCRIPTION: MVAC ENCLOSURE 15 HP TRIPLEX CLAW 200G TANK		DRAWING NUMBER: MVECT1505xx1	REVISION: A	SIZE: D