

## Product Line Overview

The Powerex FirstCall™ fully-automatic medical gas manifold delivers an uninterrupted supply of medical gas to a facility from multiple high-pressure cylinders equally divided into two banks. The manifold is cleaned, tested, and prepared for the intended medical gas service. It is constructed in accordance with requirements of the latest edition of NFPA 99 and CGA.

## Features and Benefits

- Designed and manufactured in the USA
- 5 year warranty on parts, 2 year warranty on labor
- Industry-leading flow capacity
- 7" high-resolution touchscreen HMI graphically displays bank pressure, primary/secondary bank status, final line pressure, changeover set point, and alarm status
- System logic controlled by next generation PLC technology
- Ethernet connectivity using BACnet over IP protocol to building management system – optional
- Final line pressure transducer eliminates the need for an additional high/low pressure switch
- Robust changeover design using dome-loaded primary regulators controlled by dual solenoids
- Robust piston-style final line regulator
- Removable cabinet enclosure for improved service access
- Single point vent connection
- Maintenance mode
- Push-button bank changeover
- ¾" source valve included
- Easy mounting bracket system
- NEMA 4 enclosure optional
- Heaters optional for Nitrous Oxide and Carbon Dioxide
- Input power 110 VAC to 240 VAC, 50 to 60 Hz

## Specifications

The Powerex FirstCall™ NFPA 99 Medical Gas Manifold is a digital, fully automatic manifold that automatically switches from the "In Use" bank to the "Reserve" bank



without fluctuation in line delivery pressure. Each bank goes through two stages of pressure regulation, beginning with the dome-loaded bank regulators and then the piston-style final line regulators. After the depleted cylinders are replaced, the manifold automatically designates that bank as the reserve supply, with no manual resetting of valves or levers required.

"In Use" status, "Ready" or "Reserve" status, bank pressure, final line pressure, changeover set point, and alarm status are all graphically displayed on the 7" high-resolution touchscreen HMI. The amount of gas left in each bank is graphically displayed using the pressure data. The HMI has a password-protected Settings menu where the user can adjust the changeover set point, review alarm history, change BACnet settings, and turn on Maintenance Mode. Maintenance Mode disables alarms for 15 minutes so maintenance or diagnostic work can be performed without sending any nuisance alarms to the Master Alarm Panel.

All Powerex FirstCall™ Manifolds come equipped with an Ethernet port that uses BACnet over IP protocol to connect to building management systems if required by the facility. BACnet activation is optional. Alarm signals, including "Main Line Pressure High", "Main Line Pressure Low", and "Changeover to Secondary Supply" are all centrally generated by the PLC. Push-button terminal blocks are located near the PLC and are used for dry contact connection to the Master Alarm Panel. The final line transducer ties into the PLC as well, so no additional final line high/low pressure switch is required.

The manifold is constructed with intermediate and final line pressure relief valves that are both connected to a single vent port with a 1/2" FNPT connection. Threaded bleed valves are installed on all regulators to assist in servicing. All regulators are isolatable with installed shut-off valves and check valves. The solenoid valves' gas lines also have a shut-off valve for isolation. All regulators, plumbing, and control switching equipment are cleaned for use with oxygen service. The manifold cabinet is constructed of powder-coated steel with removable sides for improved service access. An optional installed NEMA 4 rated enclosure is available to cover the PLC, power supply, circuit breaker, and terminal blocks.

See separate Header literature for Headers specifications and part numbers, as well as separate Heater literature for Heater information and part number.

Flow Characteristics at Min. Cylinder Pressure (Changeover)	
Delivery Line Pressure (PSIG)	Min. Delivery Line Flow (SCFH)
55	3300
100	4620
180	5340

*NOTE: The flow capacity of the Nitrous Oxide and Carbon Dioxide manifolds depends on the environmental conditions at the installation site and the number of cylinders in service. Installing these types of manifolds in a location that exposes them to ambient temperatures below 32°F (0°C) is not recommended.*

### Ordering Information

#### MFLD-CYL-NFPA-GG(-N4)(-B)

GG = GAS TYPE

O2 = Oxygen (55psig)

AIR = Medical Air (55psig)

N2O = Nitrous Oxide (55psig)

N2 = Nitrogen (180psig)

CO2 = Carbon Dioxide (55psig)

INST = Instrument Air (180psig)

N4 = NEMA 4 (option)

B = BACnet (option)

Ex. MFLD-CYL-NFPA-O2-B

MFLD-CYL-NFPA-N2O-N4

NOTE: Alternative final line pressures for each gas, including 100psig, are available upon special request.

### Dimensions

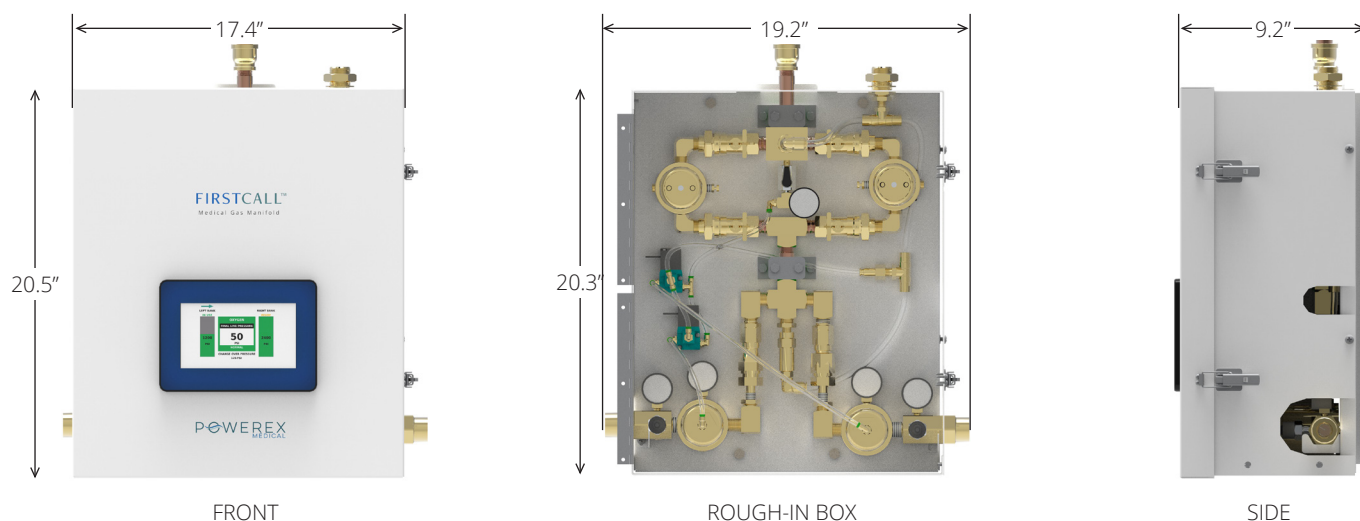

Manifold with Headers

