

Specification

General

The Powerex laboratory vacuum system is designed to create a suction system to remove unwanted fluids or gases from laboratory working areas. The laboratory vacuum system package is compliant with the NFPA 99 requirements for Risk Category 3 laboratory systems. Each system is completely tested before shipment and includes:

- Multiple vacuum pumps and associated equipment.
- ASME air receiver.
- NEMA 12 multiplex control panel.

Each pump is factory piped to a common intake manifold. Vibration isolation pads are included with the system.

Claw Vacuum Pump

Each pump shall be a rotary claw type vacuum pump, and shall be direct-driven through a shaft coupling by a C-face, TEFC electric motor.

- Each vacuum pump shall be dry-running, featuring two claw-type, non-contacting rotors and shall not require any sealing fluid in the pumping chamber, assuring virtually maintenance-free operation.
- 7-15HP vacuum pumps shall include an internal relief valve; pumps 6.4 HP and below do not. Each vacuum pump shall include an internal relief valve, and a built-in, anti-suck-back valve mounted at the pump inlet.
- Each vacuum pump includes a built-in, anti-suckback valve mounted at the pump inlet.
- Each pump within the system shall include a check valve, inlet and discharge flex connectors, an inlet filter and a pump isolation valve.

Motor

The motor is continuous duty, C-face, TEFC, suitable for 208-230, or 460V, 3 phase, 60 hertz electrical operation.

Air Receiver

The system shall include an ASME rated air receiver. The tank shall be internally lined and come with a manual drain and sight gauge. Systems with Basic Controls are also equipped with a vacuum gauge. Receiver is plumbed so that system vacuum must pass through the air receiver prior to the pumps to provide additional protection for the pumps.

Premium NFPA Control Panel

The control system provides automatic lead/lag sequencing and automatic alternation of all pumps in order to equalize the amount of usage among the available vacuum pumps. The Premium NFPA Control Panel shall include a gateway server card and all features listed below:

- PLC controller and a 6" color touch screen panel which displays the operating status of the unit.
- Building automation communication gateway with BacNet® protocol and Web server features. Web server features include email notifications in case the system is in alarm or has achieved one its maintenance intervals and requires service.
- Ethernet port for connection to BacNet® server or direct connection to facility Ethernet for viewing of system operations and status via device IP-address.
- UL508A listed control panel in a NEMA 12 enclosure. The panel door will include: the color touch screen, audible and visual alarms with an acknowledge button, and an HOA switch for each pump.
- Magnetic starters.
- Vacuum transducer for process control.
- Single point power connection.
- Redundant 120VAC control transformers with fused primary and secondary protection.
- System overload trip, high temperature conditions, low vacuum or maintenance intervals for the pump will result in visual and audible alarms.

Optional Auto Purge

NOTE: This option is available with our Premium NFPA Control Panel. It is not available on systems with Basic NFPA controls.

Systems with the auto purge feature will include:

- Control and operation of air actuated and/or electric isolation and purge valves.
- 3-position mode switch (Auto-Off-Manual).
- Pump Status (PUMP ON, PUMP READY, PUMP OFF, PUMP PURGING).

Pumps will run through an automatic purge cycle every 24 hours (after alternation phase), to purge any gases from the pump to atmosphere. A 3-position switch is provided to select automatic purge, manual purge, or purge off modes.

NOTE: Pneumatic purge isolation valves require 80 psi compressed air to be field supplied.

Dimensions					
Model	Dim. A	Dim. B	Dim. C	Inlet	Outlet (x2)
LCPD1005	66"	59"	83"	3"	2"
LCPD1505	90"	75"	84"	4"	2"

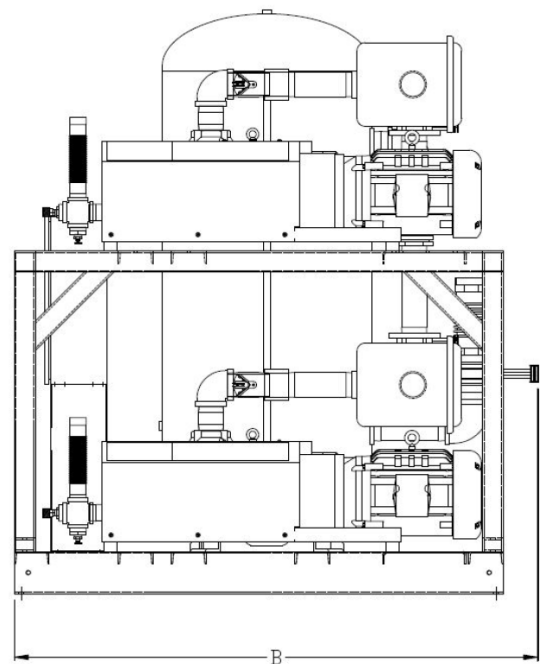
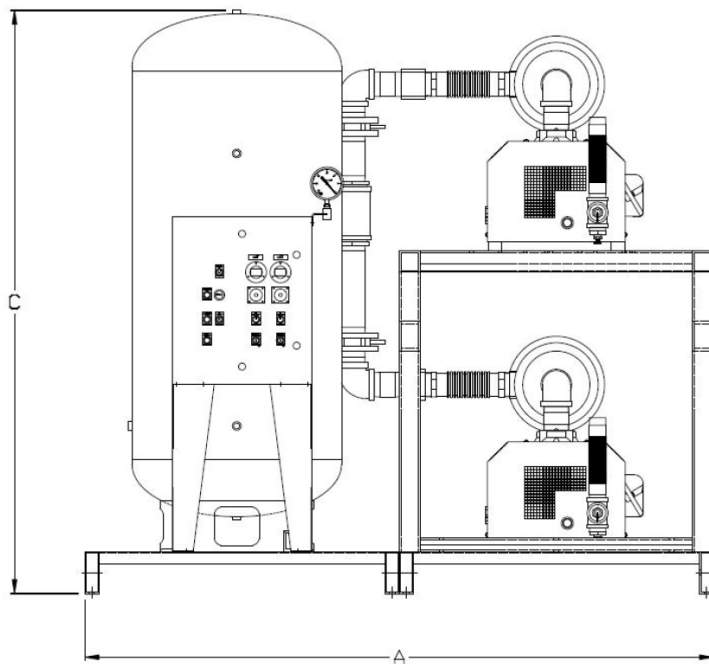
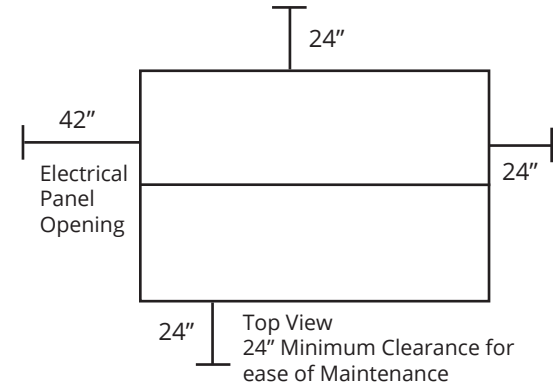

Laboratory Claw Vacuum Package									
Model	Pump HP	SCFM @ 19" Hg each ⁽¹⁾	Tank Size (gal)	BTU/Hr ⁽¹⁾	dB(A) Level ⁽¹⁾	System F.L.A. ⁽¹⁾			System Weight (lbs)
						208V	230V	460V	
LCPD1005	10 (2)	174	200	43,350	86	56.4	49.2	25.6	3100
LCPD1505	15 (2)	258	200	65,026	86	83	72	37	3400

Notes:
 1 – SCFM, BTU, dB(A), and FLA values listed are with all pumps running.
 2 – 3 Year Limited Warranty.