

Specification

General

The Powerex Skid Mount Scroll Medical Air System is designed to provide medical breathing air for hospital and medical institutions. This system meets the latest NFPA 99 requirements for Category 1 systems. Each system is completely tested before shipment and includes:

- Multiple oil-less scroll air compressors and associated equipment
- Corrosion resistant air receiver
- Redundant medical desiccant air dryers with purge control
- Medical control panel
- Dew point and CO monitors

The only field connections required will be system intake, exhaust, and power connection at the control panel. All interconnecting piping, wiring, and vibration isolation pads are included with the system.

Oilless Scroll Compressor Pump

Each compressor shall be belt driven oil-less rotary scroll single stage, air-cooled construction with absolutely no oil needed for operation. The rotary design shall not require any inlet or exhaust valves and shall be rated for 100% continuous duty.

- Tip seals shall be of a composite PTFE material and be rated for 8,000 hours
- Compressor bearings shall be external to the air compression chamber and shall all be serviceable for extended compressor life. Bearing maintenance shall not be required until 8,000 run hours. Compressors with bearings that are not accessible for service have a limited life span and shall not be accepted. Compressors shall have an integral radial flow fan for cooling
- Each compressor shall have flexible connectors on intake and discharge, two discharge check valves, and a high discharge temperature shut down switch
- An air-cooled aftercooler is provided with a dedicated cooling fan to provide a maximum approach temperature of 15 degrees F above ambient

- Unloader valve is provided on the discharge for load-less startup and shutdown
- Each compressor module shall have a safety relief valve, an isolation valve, and a moisture separator with automatic drain

Motors

Each compressor shall be belt driven by an ODP, NEMA construction motor. OSHA-compliant belt guards are provided.

Motor Slide Base

Maintenance feature designed for easy adjustment of belt tension from the motor side on the pump/motor assembly.

- Robust single screw linear belt tension adjustment
- Custom compact design

Intake Filters

Every system has a remote inlet with one filter per pump. Each filter/compressor may be isolated to enable servicing. Only the compressor being serviced must be shutdown. The inlet filter system shall be located on the compressor package and plumbed upstream of the compressor pumps.

Air Receiver

- The system shall include an ASME air receiver rated for 200 PSI MAWP. The tank shall be equipped with:
 - A pressure gauge and a safety relief valve
 - A sight gauge
 - By-pass valves to allow tank isolation without system shutdown

An automatic electronic tank drain with manual override. The receiver shall be internally lined for corrosion resistance.

Service Slide

The service slide enables easy maintenance access to each pump and motor basemount without having to remove them from the system.

- Unique maintenance friendly base mount slide design
- Allows safe access to important system components necessary
- for improved pump life
- Allows faster component replacement time

Desiccant Air Dryers

Each desiccant dryer shall be sized for the peak calculated system demand to provide a pressure dew point to meet NFPA 99 standards.

- Dryer controls shall include a re-pressurization cycle to prevent shocking of the desiccant bed prior to switching towers
- An integral purge saving control system shall be provided and shall suspend the purge air loss during periods of low demand

Filtration and Pressure Reducing Station

Each filter/dryer/regulator assembly shall be plumbed with bypass valves to enable service without disrupting air flow to the facility. Each assembly also includes a sample air port. The filtration systems consist of two stages of filtration.

- The first stage of filtration shall include dual pre-filters with element change indicators and automatic condensate drains, installed up-stream of the air dryers
- The second stage shall include dual particulate filters with element change indicators installed downstream of the air dryers
- A dual set of pressure reducing valves with pressure gauges shall be installed downstream of the final filters and shall be adjusted to an outlet pressure of 55 psig

Premium NFPA Control Panel

This control system provides automatic lead/lag sequencing and automatic alternation of all compressors in order to equalize the amount of usage among the available compressors. The Premium NFPA Control Panel shall include additional features listed below:

- UL508A listed control panel in a NEMA 12 enclosure with the following accessories for each pump: an HOA switch, a magnetic starter with 3 leg overload protection, a high temperature shutdown with audible and visual alarm, an hour meter and a compressor run indicator
- Motor soft-starters provide improved torque control on pumps during start-up and shutdown
- High resolution, color touch screen HMI displays the operating status of the unit. The touch screen will display pump status, pump faults, pump run hours, system pressure, system alarms and service alert notifications for the pumps, dryers, dew point and CO monitors
- BACnet/IP communication via Ethernet port
- PLC controller with control logic to start the lag compressor automatically if the lead compressor fails to operate, a reserve compressor in-use alarm with visual and audible alarms, and redundant control circuit transformers with visual indication of a main transformer failure
- Dry contacts on a labeled terminal strip for remote alarm
- monitoring and an acknowledge pushbutton for horn silencing
- Control logic to start the lag compressor automatically if the lead compressor fails to operate
- Integrated dew point and carbon monoxide monitors. The touch screen will display dew point and CO readings and provide audible and visual high dew point and CO alarms
- Dryer maintenance notifications and service alerts at set run- hour intervals
- Ambient temperature monitoring with alert/ alarm, and data logging capabilities

Base Model Configuration

Dimensions													
Model	Dim. A	Dim. A1	Dim. B	Dim. B1	Dim. C	Dim. C1	Dim. D	Dim. D1	Dim. E	Dim. E1	Dim. F	Inlet	Outlet
MSEQ2256	42.0"	44.0"	37.8"	44.6"	61.2"	71.8"	98.3"	99.3"	32.0"	34.6"	96.2"	2"	2"
MSEQ30B6	42.0"	44.0"	37.8"	44.6"	61.2"	71.8"	98.3"	102.6"	32.0"	39.0"	72.0"	2"	2"

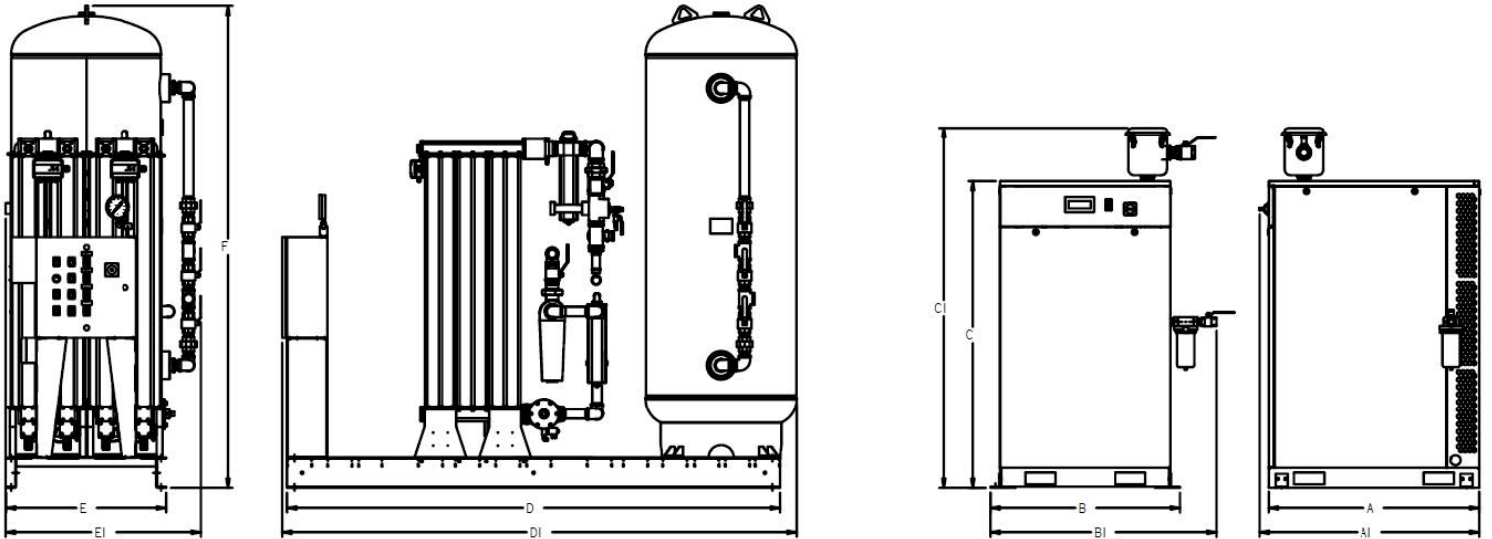
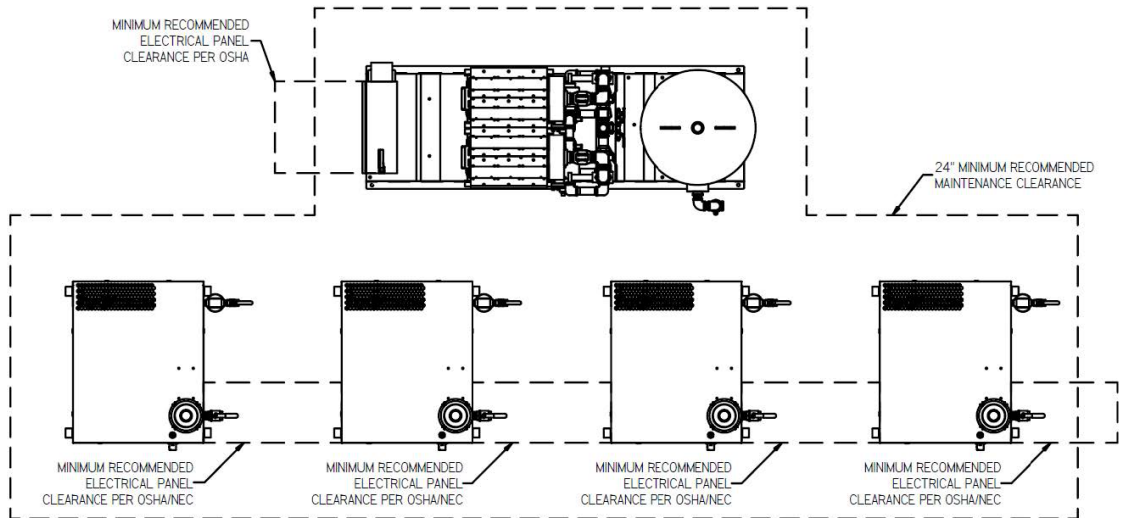

Notes:

- Allow a minimum of 36" in front of control panels for maintenance and ventilation. All other sides require 24" clearance.

Medical Scroll Enclosure System Specifications									
Model	HP	SCFM @ 50 PSIG	Tank Size (gal)	BTU/Hr	dB(A) Level	System F.L.A.		System Weight (lbs)	
						230 V	460 V		
MSEQ2256	22.5 (4)	214.2	240	171,749	68	53.9	27.9	7500	
MSEQ30B6	30.9(4)	284.4	240	228,999	69	71	36.5	8000	